

Manual of Upper Primary Science Kit

Classes VI, VII and VIII



MANUAL OF UPPER PRIMARY SCIENCE KIT

CLASSES VI, VII AND VIII



विद्यया ऽ मृतमश्नुते



एन सी ई आर टी
NCERT

**राष्ट्रीय शैक्षिक अनुसंधान और प्रशिक्षण परिषद्
NATIONAL COUNCIL OF EDUCATIONAL RESEARCH AND TRAINING**

**1335 – MANUAL OF UPPER PRIMARY
SCIENCE KIT**

ISBN 978-93-5007-050-5

First Edition

September 2014 Ashvina 1936

Reprinted

February 2018 Magha 1939

October 2019 Kartika 1941

June 2020 Jyeshtha 1942

September 2020 Bhadrapada 1942

August 2024 Shravana 1946

PD 15T BS

© **National Council of Educational
Research and Training, 2014**

₹ 195.00

*Printed on 80 GSM paper with
NCERT watermark*

Published at the Publication
Division by the Secretary, National
Council of Educational Research
and Training, Sri Aurobindo Marg,
New Delhi 110 016 and printed
at Taj Printers, 69/6A, Najafgarh
Road Industrial Area, Near Kirti
Nagar Metro Station, New Delhi
110 015.

ALL RIGHTS RESERVED

- ❑ No part of this publication may be reproduced, stored in a retrieval system or transmitted, in any form or by any means, electronic, mechanical, photocopying, recording or otherwise without the prior permission of the publisher.
- ❑ This book is sold subject to the condition that it shall not, by way of trade, be lent, re-sold, hired out or otherwise disposed of without the publisher's consent, in any form of binding or cover other than that in which it is published.
- ❑ The correct price of this publication is the price printed on this page, Any revised price indicated by a rubber stamp or by a sticker or by any other means is incorrect and should be unacceptable.

**OFFICES OF THE PUBLICATION
DIVISION, NCERT**

NCERT Campus
Sri Aurobindo Marg
New Delhi 110 016 **Phone : 011-26562708**

108, 100 Feet Road
Hosdakere Halli Extension
Banashankari III Stage
Bengaluru 560 085 **Phone : 080-26725740**

Navjivan Trust Building
P.O.Navjivan
Ahmedabad 380 014 **Phone : 079-27541446**

CWC Campus
Opp. Dhankal Bus Stop
Panihati
Kolkata 700 114 **Phone : 033-25530454**

CWC Complex
Maligaon
Guwahati 781 021 **Phone : 0361-2674869**

Publication Team

Head, Publication Division : *Anup Kumar Rajput*

Chief Production Officer : *Arun Chitkara*

Chief Editor : *Bijnan Sutar*

Chief Business Manager : *Amitabh Kumar*

Editor : *Hemant Kumar*

Production Officer : *Deepak Jaiswal*

Cover

DTP Cell, PD

Preface

This Manual of Upper Primary Science Kit for Classes VI, VII and VIII not only describes the kit items and their uses, but also details the activities that can be done with the kit material and are based on NCERT science textbooks for Classes VI, VII and VIII. Thus, the Science Kit serves as a portable laboratory whereas the manual supplements and extends the exploration of various concepts through activities.

The activities in the manual are structured in a manner so that the students can question, explore and finally discover the concepts involved. The Manual is based on an approach wherein attempts are made to inculcate the temper of scientific enquiry and understanding of the subject matter among the students. The success and usefulness of the Kit and the Manual will depend on how best the teachers can motivate the students to use the Kit items rather than a mere demonstration by them.

Such an activity-based approach has been followed in preparation of the science textbooks in the NCERT, which requires that the students themselves do the different activities. In the process of doing the activities using the present science kit not only will the students feel the excitement, but it will also give them opportunities to think and explore and which may not be achievable by a reading of the textbooks alone. Of course, this requires time and keen interest on the part of the teachers. It is hoped that the teachers would also enjoy making use of the Kit and the Manual.

In this Kit, we have included items for doing activities using micro-scale laboratory technique. Use of micro-scale techniques not only reduces the cost of the chemicals and apparatuses to a considerable extent, but also is safe and environment friendly.

The NCERT appreciates the hard work done by the experts, teachers, technical staff of the NIE Workshop, support of Publication Division in the development of the Kit and the Manual.

The Council acknowledges the contribution of Prof. H.O. Gupta, then Head of NIE Workshop under whose supervision this manual was developed. Thanks are also due to Professor Hukum Singh and Professor V.P. Srivastava for editing the manuscript.

We welcome comments and suggestions from our readers for further improvement of this manual.

R.K. Parashar
Professor and Head
DEK, NCERT
New Delhi

Acknowledgements

The National Council of Educational Research and Training (NCERT) expresses its gratefulness to Dr. K.K. Arora, *Reader* (Chemistry), Department of Chemistry, Zakir Hussain College, New Delhi; Shri J.P. Agarwal, *Principal* (Retd.), Ashok Vihar-III, New Delhi; Dr. K.K. Gupta, *Reader* (Retd.), Shalimar Bagh, New Delhi; Dr. Gita Mathur, *Reader* in Botany, Department of Botany, Gargi College, New Delhi; Shri Ved Ratna, *Professor* of Physics (Retd.), Saraswati Vihar, New Delhi; Shri Kanhaiya Lal, *Principal* (Retd.), Delhi Gate, Ghaziabad; *Professor* Sunita Malhotra, *Professor* of Chemistry and Director, School of Science, IGNOU; Dr. Rashmi Sharma, *Lecturer* in Chemistry, NERIE, Shillong; Dr. B.B. Swain, *Professor* of Physics (Rtd), Bhubhaneswar; Dr. A.K. Vashistha, *Principal*, G.B.S.S.S., Jafrabad, Delhi; Shri Raja Kishore Nayat, *TGT*, DMS RIE, Ajmer; Shri Anil Kumar Jena, *TGT*, DMS, RIE, Bhubneswar; Dr. H.C. Jain, *Professor* of Physics and *Principal* (Retd.), RIE, Ajmer; Mrs. Sini Annie Abraham, *TGT*, DPS, R.K.Puram, New Delhi; Dr. Babeeta Chrungu Kaula, *Sr. Lecturer*, Department of Botany, Zakir Hussain College, Delhi; Dr. Sarita Kumar, *Reader*, Acharya Narendra Dev College, Delhi; H.L. Satheesh, *TGT*, DMS, RIE, Mysore; Mrs. Nishi Saraswat, *PGT*, Kendriya Vidyalaya-I, Delhi; Dr. S.C.Jain, *Professor* of Botany, RIE, Bhubaneswar; Mrs. Vandana Singh, *TGT*, Kendriya Vidyalaya, JNU, Delhi; Mr. D.C. Pandey, *Vice-Principal* (Retd.), Jalvayu Vihar, Noida; Mr. R.S. Dass, *Vice-Principal*, (Retd.), Vaishali, Gaziabad; Dr. S.V. Sharma, *Sr. lecturer* in Physics, RIE, Ajmer; Mrs. Amina Ansari, *TGT*, Sardar Patel Vidyalaya, Lodhi Estate, Delhi; Mr. Johnson David, *Lecturer* (Retd.), in Biology, E-215, Saraswati Kunj Society, Plot No. 25, I.P. Extension, Delhi; Mrs. Raji Kamalasanan, *PGT*, DTEA Sr. Sec. School, R.K.Puram, Sector-4, New Delhi; Mrs. Meeta Purkayastha, *PGT*, New State Academy Senior Sec. School, Pitampura, New Delhi; Mr. Mandharlal Patel, Govt. R.N.S. Sr. Sec. School, Piperiya, M.P.; Mr. R.P. Sharma, *Education Officer* (Science), CBSE, Shiksha Sadan, 17, Rouse Avenue, New Delhi; Ms. S.L. Varte, *Lecturer*, DESM, NCERT; Dr. R.S. Sandhu, *Professor* of Chemistry, DESM, NCERT; for their contribution in the development, reviewing, editing, refining and finalisation of the manuscript.

Special thanks are due to Professor Dharam Prakash, NIE-Workshop, NCERT, New Delhi; Dr. Kuldeep Singh, *Reader*, NIE-Workshop, NCERT, New Delhi; Dr. S.K. Dash, *Reader*, RIE, Bhubaneswar; Dr. Gagan Gupta, *Reader*, DESM, NCERT, New Delhi, for their significant contribution in preparation of the manual and the kit.

The Council acknowledges with thanks the contribution of NIE-Workshop staff: Shri Manoj Dubey (*JPF*); Shri Ajay Ambwani (Computer Assistant); Shri Anil Nayal (*Draftsman*) and Davendra Kumar Sikkha(UDC) for development of the kit manual and Shri. P. Chandra, Shri G.D. Sharma, Shri Narendra Kumar, Shri Attar Singh, Shri Amarnath, Shri Balbir Singh Rawat, Shri Amrish Kumar, Shri Satish Sharma, Shri Rambhool Singh and Shri Rajendra Kumar for technical support in development of the kit.

Contents



Preface		iii
Acknowledgements		v
List of Science Kit Items for Upper Primary Stage		xv
Introduction		1
6.1 Food: WHERE DOES IT COME FROM?		
ACTIVITY 6.1.1	How to prepare sprouts from whole seeds?	6
6.2 Components of Food		
ACTIVITY 6.2.1	How can we identify the major components in our food?	8
6.3 Fibre to Fabric		
ACTIVITY 6.3.1	How do you identify a fibre?	10
6.4 Sorting Materials into Groups		
ACTIVITY 6.4.1	How do you classify materials/objects on the basis of their appearance?	12
ACTIVITY 6.4.2	Do substances dissolve in water?	14
ACTIVITY 6.4.3	What happens when other liquids are added to water?	16
ACTIVITY 6.4.4	Can you see through materials?	18
6.5 Separation of Substances		
ACTIVITY 6.5.1	How will you separate mud from muddy water?	20
ACTIVITY 6.5.2	How will you separate salt from salt solution?	23
ACTIVITY 6.5.3	How will you separate a mixture of sand and salt?	25
ACTIVITY 6.5.4	Can a given volume of water dissolve any amount of a substance?	27
ACTIVITY 6.5.5	How can a saturated solution be made to dissolve some more substance?	29
ACTIVITY 6.5.6	Are different substances dissolved in varying quantities in water?	31

Contents



Preface		iii
Acknowledgements		v
List of Science Kit Items for Upper Primary Stage		xv
Introduction		1
6.1 Food: WHERE DOES IT COME FROM?		
ACTIVITY 6.1.1	How to prepare sprouts from whole seeds?	6
6.2 Components of Food		
ACTIVITY 6.2.1	How can we identify the major components in our food?	8
6.3 Fibre to Fabric		
ACTIVITY 6.3.1	How do you identify a fibre?	10
6.4 Sorting Materials into Groups		
ACTIVITY 6.4.1	How do you classify materials/objects on the basis of their appearance?	12
ACTIVITY 6.4.2	Do substances dissolve in water?	14
ACTIVITY 6.4.3	What happens when other liquids are added to water?	16
ACTIVITY 6.4.4	Can you see through materials?	18
6.5 Separation of Substances		
ACTIVITY 6.5.1	How will you separate mud from muddy water?	20
ACTIVITY 6.5.2	How will you separate salt from salt solution?	23
ACTIVITY 6.5.3	How will you separate a mixture of sand and salt?	25
ACTIVITY 6.5.4	Can a given volume of water dissolve any amount of a substance?	27
ACTIVITY 6.5.5	How can a saturated solution be made to dissolve some more substance?	29
ACTIVITY 6.5.6	Are different substances dissolved in varying quantities in water?	31

6.6 Changes Around Us

ACTIVITY 6.6.1	Can you identify some changes which can be reversed?	32
ACTIVITY 6.6.2	Can you explain the difference between changes which can be reversed and those which cannot be reversed?	34
ACTIVITY 6.6.3	Are 'burning of candle' and 'melting of wax' changes of the same type?	36

6.7 Getting to Know Plants

ACTIVITY 6.7.1	Why does the colour of white petals of a flower change when a flowering twig is dipped in some coloured solution?	38
ACTIVITY 6.7.2	How to study the venation pattern in leaves?	40
ACTIVITY 6.7.3	How to study transpiration in plants?	43
ACTIVITY 6.7.4	Why leaves are called the kitchen of the plant?	45
ACTIVITY 6.7.5	What are the major types of roots?	47
ACTIVITY 6.7.6	What are the functions of roots?	49

6.8 Motion and Measurement of Distances

ACTIVITY 6.8.1	How can we recognise periodic motion and circular motion?	51
ACTIVITY 6.8.2	How can we measure the perimeter of a circular object using a thread?	53
ACTIVITY 6.8.3	How can we recognise the rectilinear motion of an object?	55

6.9 Light, Shadows and Reflections

ACTIVITY 6.9.1	Do all substances allow light to pass through them?	57
ACTIVITY 6.9.2	How can you make an opaque paper translucent?	59
ACTIVITY 6.9.3	How are shadows formed?	60
ACTIVITY 6.9.4	How does light travel?	62
ACTIVITY 6.9.5	How an image is formed in a pinhole camera?	63
ACTIVITY 6.9.6	What happens to light falling on a plane mirror?	65

ACTIVITY 6.9.7	How does an image of a person appear in a plane mirror?	67
ACTIVITY 6.9.8	What is the nature of the image formed by a plane mirror?	68
ACTIVITY 6.9.9	How can we see objects which cannot be seen directly?	69

6.10 Electricity and Circuits

ACTIVITY 6.10.1	How can we make a simple electric circuit?	70
ACTIVITY 6.10.2	How can we identify conductors and insulators?	72
ACTIVITY 6.10.3	How can we make an electric switch?	74
ACTIVITY 6.10.4	Does tap water conduct electricity?	75

6.11 Fun with Magnets

ACTIVITY 6.11.1	How can we test whether a given object is a magnet or not?	77
ACTIVITY 6.11.2	In what different shapes magnets are usually made?	80
ACTIVITY 6.11.3	Do all materials experience mutual attraction with a magnet?	82
ACTIVITY 6.11.4	Does a magnet attract iron filings/nails equally at all its points?	84
ACTIVITY 6.11.5	How do we name the poles of a magnet?	86
ACTIVITY 6.11.6	Can we make a magnet by ourselves?	88
ACTIVITY 6.11.7	How can we make a simple compass needle?	89
ACTIVITY 6.11.8	Does the pole of a magnet always attract the poles of the other magnet?	90
ACTIVITY 6.11.9	How can we compare the strength of two magnets using a compass needle?	92
ACTIVITY 6.11.10	Can a magnet lose its magnetic properties when heated?	93

6.12 Water

ACTIVITY 6.12.1	What makes evaporation faster or slower?	95
ACTIVITY 6.12.2	Is there any water in air?	98

6.13 Air Around Us

ACTIVITY 6.13.1	What can moving air do?	100
ACTIVITY 6.13.2	Is air present everywhere? Is an empty bottle really empty?	102
ACTIVITY 6.13.3	What does air contain?	104

7.1 Nutrition in Plants

ACTIVITY 7.1.1	What are the conditions necessary for photosynthesis?	108
----------------	---	-----

7.2 Heat

ACTIVITY 7.2.1	How can we measure temperature using laboratory thermometer?	111
ACTIVITY 7.2.2	How can we measure our body temperature in degrees celsius?	113
ACTIVITY 7.2.3	How can we show that the rate of heat conducted by different substances is different?	115
ACTIVITY 7.2.4	Which of the two identical bodies (one dark-coloured and the other light-coloured) will absorb more amount of heat when kept under similar conditions?	117
ACTIVITY 7.2.5	How can we show heat transfer in liquids?	119
ACTIVITY 7.2.6	How can we show heat transfer in gases?	121

7.3 Acids, Bases and Salts

ACTIVITY 7.3.1	Is your shampoo acidic or basic?	122
ACTIVITY 7.3.2	What happens when an acid is mixed with a base?	125

7.4 Physical and Chemical Changes

ACTIVITY 7.4.1	How will you get water from ice and ice from water? How will you get water from water vapour?	127
ACTIVITY 7.4.2	Is heating of a shaving blade a physical change?	129
ACTIVITY 7.4.3	Is burning of magnesium ribbon a chemical change?	131

- ACTIVITY 7.4.4 To study the nature of change when zinc is added to copper sulphate solution? 133
- ACTIVITY 7.4.5 To study the type of change when vinegar is added to baking soda ? 135
- ACTIVITY 7.4.6 How do you get the crystals of copper sulphate from its solution? 137

7.5 Wind, Storms and Cyclone

- ACTIVITY 7.5.1 How can we show that air expands on heating and contracts on cooling? 139
- ACTIVITY 7.5.2 How can we show that air exerts pressure? 141
- ACTIVITY 7.5.3 How can we show that the air pressure gets reduced when air blows? 142

7.6 Soil

- ACTIVITY 7.6.1 How will you show that the soil collected from different places differ in composition? 144
- ACTIVITY 7.6.2 How will you show the presence of water in soil? 146
- ACTIVITY 7.6.3 How will you show that different types of soils have different water holding capacity? 147

7.7 Respiration in Organisms

- ACTIVITY 7.7.1 How to demonstrate the presence of CO_2 in air we breathe out? 149
- ACTIVITY 7.7.2 What is the role of diaphragm in breathing? 151

7.8 Transportation in Animals and Plants

- ACTIVITY 7.8.1 How can you listen to your own heart beat? 153
- ACTIVITY 7.8.2 How does water move from one cell to another in plants? 155

7.9 Reproduction in Plants

- ACTIVITY 7.9.1 How does asexual reproduction occur in plants? 157

7.10 Motion and Time

- ACTIVITY 7.10.1 How can we determine the time period of a simple pendulum? 159
- ACTIVITY 7.10.2 How can we find the speed of a normal walk? 161
- ACTIVITY 7.10.3 How can we measure time with the help of a sun-dial? 162

7.11 Electric Current and Its Effect

- ACTIVITY 7.11.1 How can we show that a current flowing through a conductor produces heating effect? 164
- ACTIVITY 7.11.2 How can we show that an electric current flowing through a conductor produces magnetic effect around it? 166
- ACTIVITY 7.11.3 How can we make an electromagnet? 168

7.12 Light

- ACTIVITY 7.12.1 How can we identify different types of lenses and mirrors? 170
- ACTIVITY 7.12.2 How can we find the nature of the image formed by a concave mirror? 173
- ACTIVITY 7.12.3 How can we find the nature of the image formed by (a) convex lens (b) concave lens? 175
- ACTIVITY 7.12.4 How can we find the composition of white light? 177
- ACTIVITY 7.12.5 How can we split sunlight into different colours? 179

8.1 Crop Production and Management

- ACTIVITY 8.1.1 Do plants need manures and fertilisers for better growth? 182

8.2 Microorganisms: FRIEND AND FOES

- ACTIVITY 8.2.1 Where do microorganisms live? 185
- ACTIVITY 8.2.2 Are microorganisms an integral part of our life? 188
- ACTIVITY 8.2.3 What is the role of microorganisms in fermentation? 190

8.3 Synthetic Fibres and Plastics

- ACTIVITY 8.3.1 Do all threads have the same strength? 192
ACTIVITY 8.3.2 Does the synthetic fibre absorb the same amount of water as the natural fabric? 194

8.4 Materials: METALS AND NON-METALS

- ACTIVITY 8.4.1 What happens when materials are hammered? 196
ACTIVITY 8.4.2 Do all materials conduct electricity? 198
ACTIVITY 8.4.3 How will you test whether rust is acidic or basic? 200
ACTIVITY 8.4.4 How will you test the nature of the gas evolved on burning of sulphur? 202
ACTIVITY 8.4.5 To test the nature of solution formed when magnesium reacts with water? 204
ACTIVITY 8.4.6 What happens when zinc reacts with hot water? 206
ACTIVITY 8.4.7 How do metals and non-metals react with dilute hydrochloric acid? 208
ACTIVITY 8.4.8 Does aluminum react with a base? 210
ACTIVITY 8.4.9 What happens when metals are immersed in the salt solution of other metals? 211

8.5 Combustion and Flame

- ACTIVITY 8.5.1 Are all substances around us combustible? 213
ACTIVITY 8.5.2 Is air necessary for combustion? 215
ACTIVITY 8.5.3 Can we heat water in a paper cup over a candle flame without burning it? 217
ACTIVITY 8.5.4 Is the flame hot throughout? 218

8.6 Cell: Structure and Function

- ACTIVITY 8.6.1 How to observe amoeba, paramecium and yeast under a microscope? 220
ACTIVITY 8.6.2 What do plant cells look like? 222

8.7 Reproduction in Animals

- ACTIVITY 8.7.1 How does asexual reproduction occur in small animals such as hydra and amoeba? 224

8.8 Force and Pressure

- ACTIVITY 8.8.1 How can we apply a force on an object without bringing it into physical contact with another object? 226
- ACTIVITY 8.8.2 How can we show that force acting on a smaller area exerts larger pressure? 228

8.9 Friction

- ACTIVITY 8.9.1 How can you measure the weight of a given object using a spring balance? 230
- ACTIVITY 8.9.2 How can you show that friction depends upon the nature of the two surfaces in contact? 232

8.10 Sound

- ACTIVITY 8.10.1 How can we distinguish between a pleasant sound and a noise? 234
- ACTIVITY 8.10.2 How can you show that sound can travel through a string? 235
- ACTIVITY 8.10.3 How can we produce waves using a slinky? 236

8.11 Chemical Effects of Electric Current

- ACTIVITY 8.11.1 How can you show that water can be splitted into its constituent elements? 238
- ACTIVITY 8.11.2 How can you use electric current for coating a metal over the surface of another metal? 240

8.12 Some Natural Phenomena

- ACTIVITY 8.12.1 How is an electroscope made? 242
- ACTIVITY 8.12.2 Do charges interact with each other? 244

8.13 Light

- ACTIVITY 8.13.1 How can you verify laws of reflection of light using a plane mirror? 246
- ACTIVITY 8.13.2 How can you show that a reflected light can be further reflected? 248
- ACTIVITY 8.13.3 How can you make your own kaleidoscope? 249
- ACTIVITY 8.13.4 How can you show that the sunlight can be splitted into different seven colours? 251

6.6 *Changes Around Us*

ACTIVITY 6.6.1	Can you identify some changes which can be reversed?	32
ACTIVITY 6.6.2	Can you explain the difference between changes which can be reversed and those which cannot be reversed?	34
ACTIVITY 6.6.3	Are 'burning of candle' and 'melting of wax' changes of the same type?	36

6.7 *Getting to Know Plants*

ACTIVITY 6.7.1	Why does the colour of white petals of a flower change when a flowering twig is dipped in some coloured solution?	38
ACTIVITY 6.7.2	How to study the venation pattern in leaves?	40
ACTIVITY 6.7.3	How to study transpiration in plants?	43
ACTIVITY 6.7.4	Why leaves are called the kitchen of the plant?	45
ACTIVITY 6.7.5	What are the major types of roots?	47
ACTIVITY 6.7.6	What are the functions of roots?	49

6.8 *Motion and Measurement of Distances*

ACTIVITY 6.8.1	How can we recognise periodic motion and circular motion?	51
ACTIVITY 6.8.2	How can we measure the perimeter of a circular object using a thread?	53
ACTIVITY 6.8.3	How can we recognise the rectilinear motion of an object?	55

6.9 *Light, Shadows and Reflections*

ACTIVITY 6.9.1	Do all substances allow light to pass through them?	57
ACTIVITY 6.9.2	How can you make an opaque paper translucent?	59
ACTIVITY 6.9.3	How are shadows formed?	60
ACTIVITY 6.9.4	How does light travel?	62
ACTIVITY 6.9.5	How an image is formed in a pinhole camera?	63
ACTIVITY 6.9.6	What happens to light falling on a plane mirror?	65

ACTIVITY 6.9.7	How does an image of a person appear in a plane mirror?	67
ACTIVITY 6.9.8	What is the nature of the image formed by a plane mirror?	68
ACTIVITY 6.9.9	How can we see objects which cannot be seen directly?	69

6.10 Electricity and Circuits

ACTIVITY 6.10.1	How can we make a simple electric circuit?	70
ACTIVITY 6.10.2	How can we identify conductors and insulators?	72
ACTIVITY 6.10.3	How can we make an electric switch?	74
ACTIVITY 6.10.4	Does tap water conduct electricity?	75

6.11 Fun with Magnets

ACTIVITY 6.11.1	How can we test whether a given object is a magnet or not?	77
ACTIVITY 6.11.2	In what different shapes magnets are usually made?	80
ACTIVITY 6.11.3	Do all materials experience mutual attraction with a magnet?	82
ACTIVITY 6.11.4	Does a magnet attract iron filings/nails equally at all its points?	84
ACTIVITY 6.11.5	How do we name the poles of a magnet?	86
ACTIVITY 6.11.6	Can we make a magnet by ourselves?	88
ACTIVITY 6.11.7	How can we make a simple compass needle?	89
ACTIVITY 6.11.8	Does the pole of a magnet always attract the poles of the other magnet?	90
ACTIVITY 6.11.9	How can we compare the strength of two magnets using a compass needle?	92
ACTIVITY 6.11.10	Can a magnet lose its magnetic properties when heated?	93

6.12 Water

ACTIVITY 6.12.1	What makes evaporation faster or slower?	95
ACTIVITY 6.12.2	Is there any water in air?	98

6.13 Air Around Us

ACTIVITY 6.13.1	What can moving air do?	100
ACTIVITY 6.13.2	Is air present everywhere? Is an empty bottle really empty?	102
ACTIVITY 6.13.3	What does air contain?	104

7.1 Nutrition in Plants

ACTIVITY 7.1.1	What are the conditions necessary for photosynthesis?	108
----------------	---	-----

7.2 Heat

ACTIVITY 7.2.1	How can we measure temperature using laboratory thermometer?	111
ACTIVITY 7.2.2	How can we measure our body temperature in degrees celsius?	113
ACTIVITY 7.2.3	How can we show that the rate of heat conducted by different substances is different?	115
ACTIVITY 7.2.4	Which of the two identical bodies (one dark-coloured and the other light-coloured) will absorb more amount of heat when kept under similar conditions?	117
ACTIVITY 7.2.5	How can we show heat transfer in liquids?	119
ACTIVITY 7.2.6	How can we show heat transfer in gases?	121

7.3 Acids, Bases and Salts

ACTIVITY 7.3.1	Is your shampoo acidic or basic?	122
ACTIVITY 7.3.2	What happens when an acid is mixed with a base?	125

7.4 Physical and Chemical Changes

ACTIVITY 7.4.1	How will you get water from ice and ice from water? How will you get water from water vapour?	127
ACTIVITY 7.4.2	Is heating of a shaving blade a physical change?	129
ACTIVITY 7.4.3	Is burning of magnesium ribbon a chemical change?	131

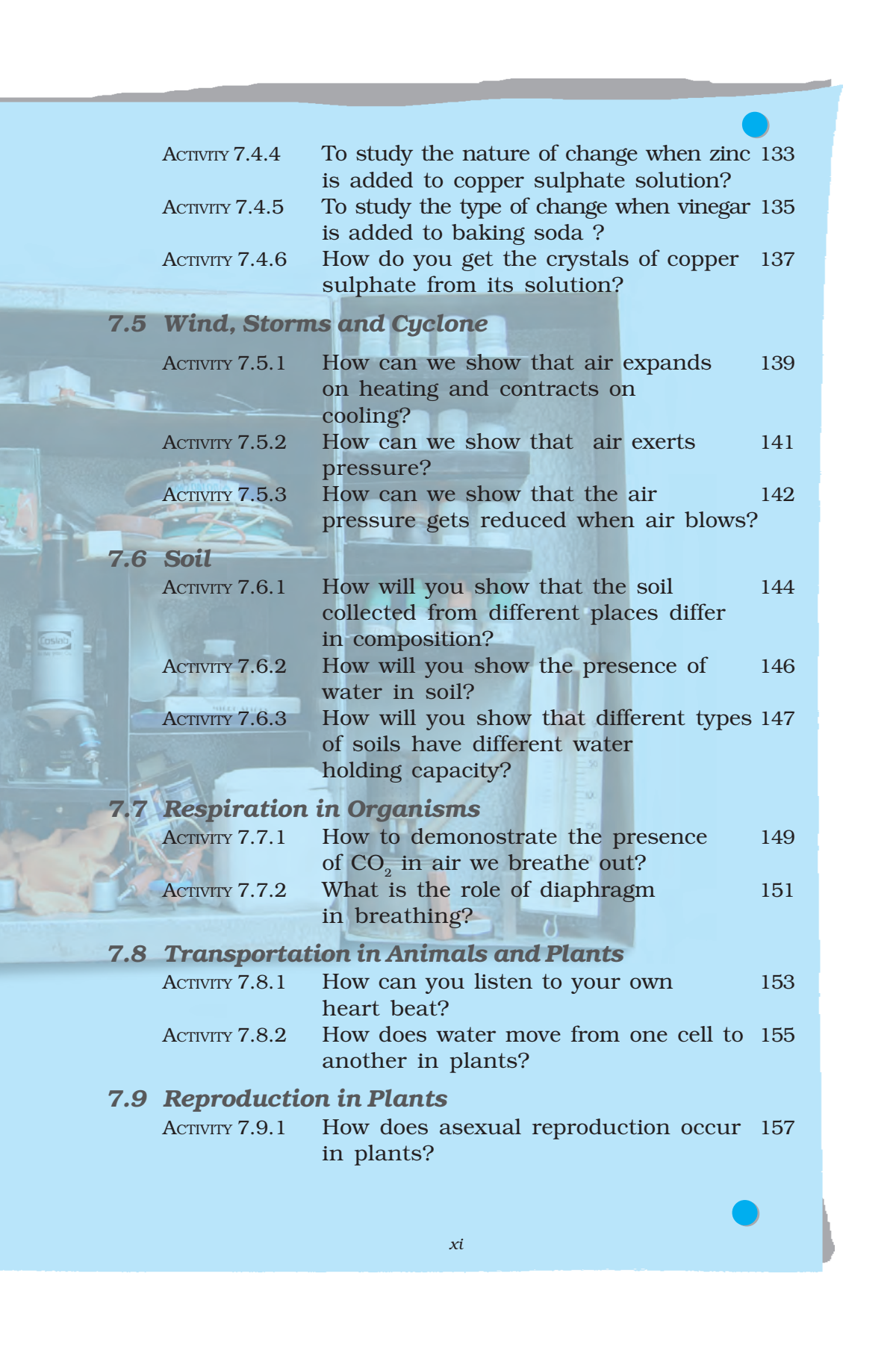
- 
- ACTIVITY 7.4.4 To study the nature of change when zinc is added to copper sulphate solution? 133
- ACTIVITY 7.4.5 To study the type of change when vinegar is added to baking soda ? 135
- ACTIVITY 7.4.6 How do you get the crystals of copper sulphate from its solution? 137

7.5 Wind, Storms and Cyclone

- ACTIVITY 7.5.1 How can we show that air expands on heating and contracts on cooling? 139
- ACTIVITY 7.5.2 How can we show that air exerts pressure? 141
- ACTIVITY 7.5.3 How can we show that the air pressure gets reduced when air blows? 142

7.6 Soil

- ACTIVITY 7.6.1 How will you show that the soil collected from different places differ in composition? 144
- ACTIVITY 7.6.2 How will you show the presence of water in soil? 146
- ACTIVITY 7.6.3 How will you show that different types of soils have different water holding capacity? 147

7.7 Respiration in Organisms

- ACTIVITY 7.7.1 How to demonstrate the presence of CO_2 in air we breathe out? 149
- ACTIVITY 7.7.2 What is the role of diaphragm in breathing? 151

7.8 Transportation in Animals and Plants

- ACTIVITY 7.8.1 How can you listen to your own heart beat? 153
- ACTIVITY 7.8.2 How does water move from one cell to another in plants? 155

7.9 Reproduction in Plants

- ACTIVITY 7.9.1 How does asexual reproduction occur in plants? 157

7.10 Motion and Time

- ACTIVITY 7.10.1 How can we determine the time period of a simple pendulum? 159
- ACTIVITY 7.10.2 How can we find the speed of a normal walk? 161
- ACTIVITY 7.10.3 How can we measure time with the help of a sun-dial? 162

7.11 Electric Current and Its Effect

- ACTIVITY 7.11.1 How can we show that a current flowing through a conductor produces heating effect? 164
- ACTIVITY 7.11.2 How can we show that an electric current flowing through a conductor produces magnetic effect around it? 166
- ACTIVITY 7.11.3 How can we make an electromagnet? 168

7.12 Light

- ACTIVITY 7.12.1 How can we identify different types of lenses and mirrors? 170
- ACTIVITY 7.12.2 How can we find the nature of the image formed by a concave mirror? 173
- ACTIVITY 7.12.3 How can we find the nature of the image formed by (a) convex lens (b) concave lens? 175
- ACTIVITY 7.12.4 How can we find the composition of white light? 177
- ACTIVITY 7.12.5 How can we split sunlight into different colours? 179

8.1 Crop Production and Management

- ACTIVITY 8.1.1 Do plants need manures and fertilisers for better growth? 182

8.2 Microorganisms: FRIEND AND FOES

- ACTIVITY 8.2.1 Where do microorganisms live? 185
- ACTIVITY 8.2.2 Are microorganisms an integral part of our life? 188
- ACTIVITY 8.2.3 What is the role of microorganisms in fermentation? 190

8.3 Synthetic Fibres and Plastics

- ACTIVITY 8.3.1 Do all threads have the same strength? 192
ACTIVITY 8.3.2 Does the synthetic fibre absorb the same amount of water as the natural fabric? 194

8.4 Materials: METALS AND NON-METALS

- ACTIVITY 8.4.1 What happens when materials are hammered? 196
ACTIVITY 8.4.2 Do all materials conduct electricity? 198
ACTIVITY 8.4.3 How will you test whether rust is acidic or basic? 200
ACTIVITY 8.4.4 How will you test the nature of the gas evolved on burning of sulphur? 202
ACTIVITY 8.4.5 To test the nature of solution formed when magnesium reacts with water? 204
ACTIVITY 8.4.6 What happens when zinc reacts with hot water? 206
ACTIVITY 8.4.7 How do metals and non-metals react with dilute hydrochloric acid? 208
ACTIVITY 8.4.8 Does aluminum react with a base? 210
ACTIVITY 8.4.9 What happens when metals are immersed in the salt solution of other metals? 211

8.5 Combustion and Flame

- ACTIVITY 8.5.1 Are all substances around us combustible? 213
ACTIVITY 8.5.2 Is air necessary for combustion? 215
ACTIVITY 8.5.3 Can we heat water in a paper cup over a candle flame without burning it? 217
ACTIVITY 8.5.4 Is the flame hot throughout? 218

8.6 Cell: Structure and Function

- ACTIVITY 8.6.1 How to observe amoeba, paramecium and yeast under a microscope? 220
ACTIVITY 8.6.2 What do plant cells look like? 222

8.7 Reproduction in Animals

- ACTIVITY 8.7.1 How does asexual reproduction occur in small animals such as hydra and amoeba? 224

8.8 Force and Pressure

- ACTIVITY 8.8.1 How can we apply a force on an object without bringing it into physical contact with another object? 226
- ACTIVITY 8.8.2 How can we show that force acting on a smaller area exerts larger pressure? 228

8.9 Friction

- ACTIVITY 8.9.1 How can you measure the weight of a given object using a spring balance? 230
- ACTIVITY 8.9.2 How can you show that friction depends upon the nature of the two surfaces in contact? 232

8.10 Sound

- ACTIVITY 8.10.1 How can we distinguish between a pleasant sound and a noise? 234
- ACTIVITY 8.10.2 How can you show that sound can travel through a string? 235
- ACTIVITY 8.10.3 How can we produce waves using a slinky? 236

8.11 Chemical Effects of Electric Current

- ACTIVITY 8.11.1 How can you show that water can be splitted into its constituent elements? 238
- ACTIVITY 8.11.2 How can you use electric current for coating a metal over the surface of another metal? 240

8.12 Some Natural Phenomena

- ACTIVITY 8.12.1 How is an electroscope made? 242
- ACTIVITY 8.12.2 Do charges interact with each other? 244

8.13 Light

- ACTIVITY 8.13.1 How can you verify laws of reflection of light using a plane mirror? 246
- ACTIVITY 8.13.2 How can you show that a reflected light can be further reflected? 248
- ACTIVITY 8.13.3 How can you make your own kaleidoscope? 249
- ACTIVITY 8.13.4 How can you show that the sunlight can be splitted into different seven colours? 251

List Of Science Kit Items for Upper Primary Stage

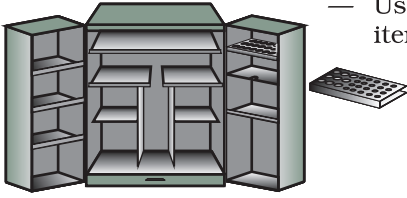
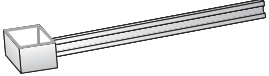
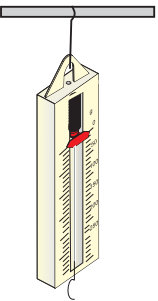
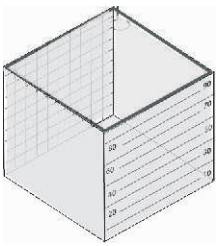
Sl. No.	Item Name (No. of Items)	Figure/Setup	Uses
GENERAL ITEMS (Category A)			
1.	Kit Box (1)		<ul style="list-style-type: none"> Used for keeping kit items
2.	1 C.C. Spoon (2)		<ul style="list-style-type: none"> Used for measurement (volume) Calibration of small vessel. Used as spoon for chemical.
3.	Spring Balance (1)		<ul style="list-style-type: none"> Weight measurement up to 250 g. Measuring the force of pull applied for pulling object on plain/rough surfaces. To show the ease in pulling object on roller. To introduce the concept of density of different metals.
4.	Decimeter cube vessel (1)		<ul style="list-style-type: none"> To give an idea of cuboid. Used as container. To understand interrelationship of length, area, volume and unit of litre (L). To measure liquid upto 1L. To find area of small irregular paper, leaf, etc.

5. Thermometer
 — Laboratory (Alcohol)
 — Clinical
 (1 each)

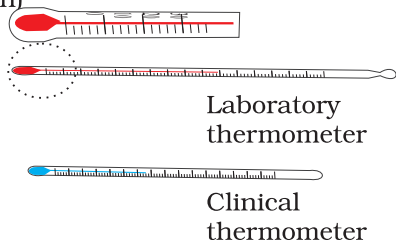

- Laboratory thermometer
 — To understand interrelationship of units for measuring temperature.
 — Used for measuring temperature of hot and cold liquids, soil, water, etc.
- Clinical thermometer
 — For recording human body temperature.

6. Laboratory stand
 Plastic Vice/
 G-clamp
 (1)
 and Boss
 (2)
 head and Clamp
 (1)

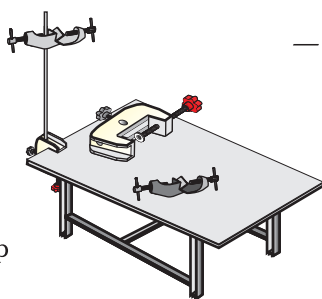

- A collapsible stand/arrangement for performing various experiments.

7. Kerosene burner
 (1)



- Used as heat source in various experiments.
 — To understand principle of wick/chimney as alternate to gas burner.

8. Tripod stand
 (1)



- Used as stand for various experiments including heating liquids in beaker, can china dish, etc.

9. Sun dial
 (1)

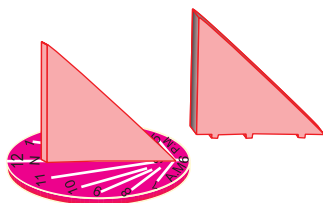

- To understand principle of old days time measuring.

10. Steel ball
(with a hole
for hook
arrangement)
(1)

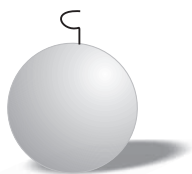

- To show experiments on friction (rolling).
- To show oscillating motion.
- To show time period of simple pendulum.

11. Aluminium
Ruler cum lever
(1)

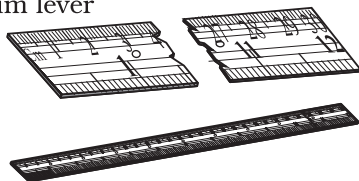

- To measure growth of plants
- To draw straight lines.
- As a measure of length, breadth, etc or distance between 2 points.

12. Pulley with frame
(2)

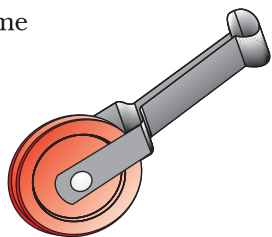

- To understand concept of pulley as a simple machine/lever.
- To demonstrate how pulley help us in doing work.

13. Aluminium
wire and
pointer
(1)

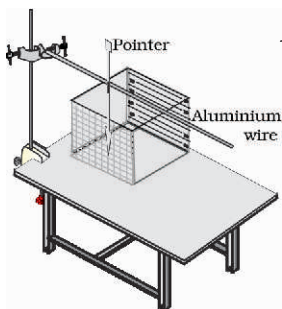

- To show expansion of Aluminium wire on heating.

14. Bimetallic
strip
(1)

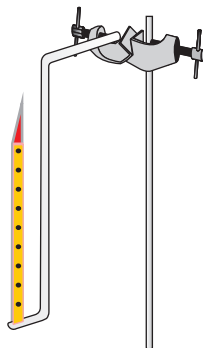

- To understand the concept of thermostat (expansion of metals).

15. Rods with holder
(1)

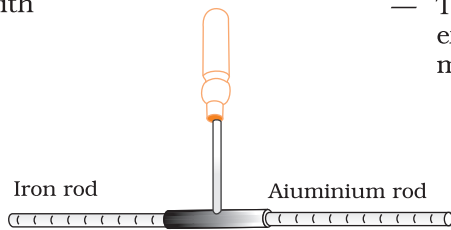

- To show variation in expansion of different metals.

16. Sitar String (Steel wire)
(1)



- Solid allows the sound to be transmitted through it
- To show that sound is produced by the to and fro motion of wire.

17. Banana clips
Connecting wire
(2 sets)

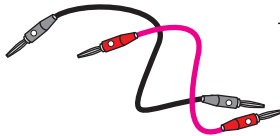

- Used as connectors on the circuit board during various electrical activities.

18. Fuses (small roll) and Model showing heating effect of current
(1)

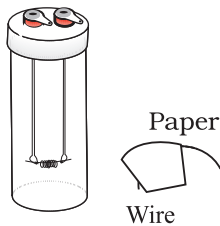

- Conversion of electric energy into heat energy.
- Function of fuse.

19. Set of four resistors
5 ohm,
10 ohm
(2Nos.)
20 ohm.
(4)

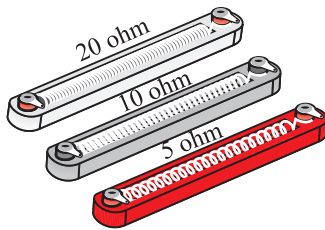

- To show resistance in series and parallel.
- To study the factors on which resistance of wire depends (Ohm's law) or current in a circuit depends upon the resistance.

20. Magnetic compass
(1)

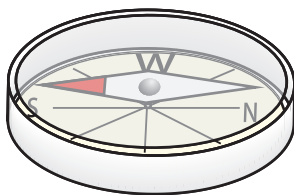

- To show how direction was known during travel around earth in olden days.
- To show effect of N.S. pole on magnetic compass.

21. Electric bell along with coil and iron core (1)

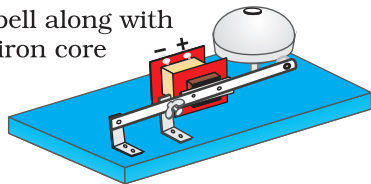

- To study open model of bell.
- To show electromagnet and its application.

22. Panel for connection (1)

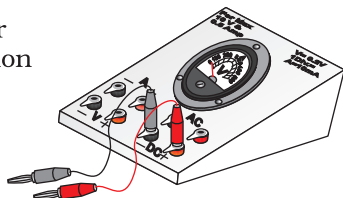

- Used as voltmeter, ammeter, etc.

23. Ray Streak apparatus and accessories

- (a) Cover with slits (1)
 (b) Screw type torch bulb (2) 6V
 (c) Plane, Concave, Convex mirror of aluminium sheet (1 each)

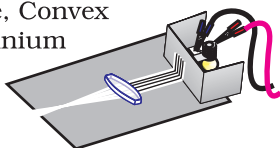

- (d) Double Convex lens (1)
 (e) Plane Concave lens and counter part of (d) 2 Nos.
 (f) Glass slab 92
 (g) Triangular Glass prism (1)

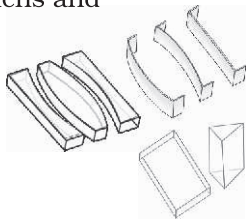

- To find out focal length of convex and concave lens.
- To study that light travel in straight line.
- Observing convergence and divergence of ray through lens.
- Image formation by concave and convex mirror.
- To study refraction of light through slab and prism.
- Dispersion of white(spectrum) light into constituent colours by prism.

24. Colour disk (1)



- Mixing of seven colours to form white light.

25. Aluminium Disc with rubber cork (1)



- To show various applications of electroscope, in use with belljar.
- To produce, transfer, preserve and identify electric charge.
- Transfer of charges.

26. Thermocol
(Styfoam ball)
(1)

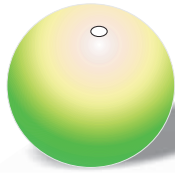

— For use in showing static changes.

27. Transparent
PVC tube
(6 mm diameter)
(1)



— To be used with funnel for stethoscope.

28. Tuning fork
(1)

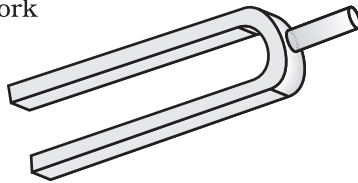

— To show sound is produced by vibrating objects.
— To show vibration of prongs with item No. 35

29. Graduated syringe
(1)

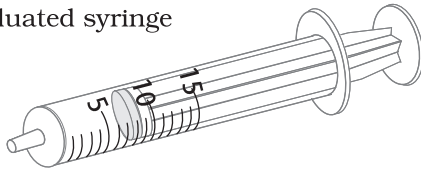

— As a measure of liquids 5-10 ml.
— To transfer liquids during experiments.

30. Copper wire
(1)

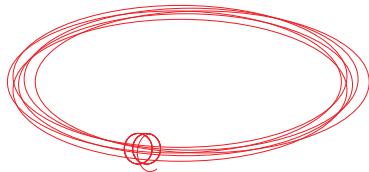

— As conducting wire in electricity related experiments.
— To make electromagnet connection .
— To show corrosive and non corrosive material, prevention, etc.

31. Protactor
(1)

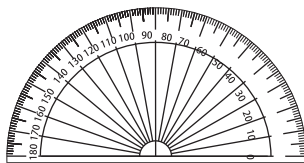

— To draw angle 0° - 180°

32. Circuit board assembly with Torch Bulbs 1.5 V (1)

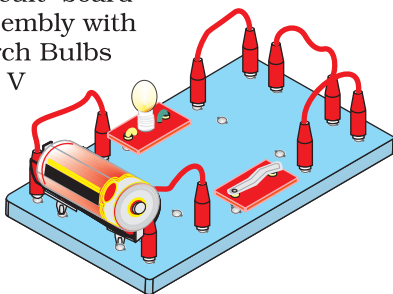

- To illustrate essential components of simple circuit.
- To show make and break of circuit.
- To show how electricity can be used to do work.
- To show electromagnet.

33. LED (Light emitting diode) (1)



- used as indicator in test lamps.

34. Slinky (1)

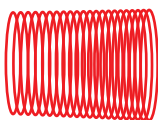

- To show longitudinal and traverse waves.

35. Magnets (1 each)

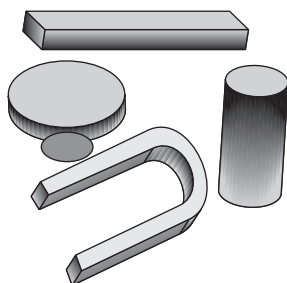

- To show that the attraction for iron is intense at end but poor at middle.
- To show existence of poles
- Freely suspended magnets always point N-S direction.
- Attraction of same pole, repulsion of opposite poles.
- Existence of magnetic field.

36. Stainless Steel electrodes fixed in cork

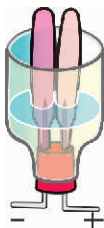

- To show concept of electrolysis, used with belljar.
- Water is made up of oxygen and hydrogen.
- know ratio of two gases.
- Testing of Hydrogen and oxygen.

37. Plastic (3mL) Pasteur pipette (10)

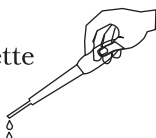

- To transfer drops of chemicals.

38. Plastic funnel
(1)

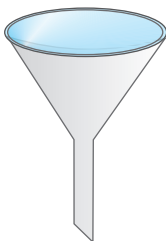

- For pouring liquids into container.
- To show filtration.
- Exhale and inhale of air/functioning of human lungs.
- To show effect of sunlight on photosynthesis.

39. Filter paper
(10 pieces)

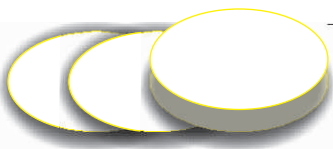

- Used for filtering the substances or product of a chemical reaction or in chromatography, etc.

40. Dispensing bottles
(20)

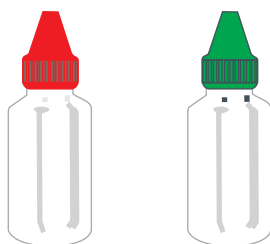

- Used to keep the chemical reagents.
- Open the cap and squeeze the bottle to dispense one or two drop.
- Label the dispensing bottle.

41. Vials
(20)

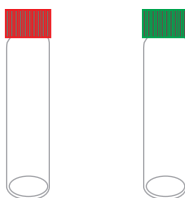

- Use as a container to store the solid chemicals.

42. Compound Microscope
(1)



- For assisting eyes in the vision of minute objects or features of objects which can't be seen with naked eye.
- To observe slides, feature of insects.
- To study structures.

43. Measuring cylinder
(1)

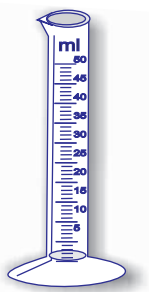

- To measure liquids during experiments.
- As container

44. Micro test tube rack
(2)

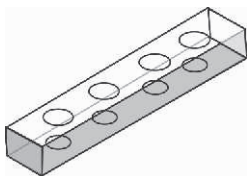

- The test tube rack is used to hold test tubes while reactions happen in them or while they are not needed.

45. Deflagrating spoon
(1)



- For burning Magnesium ribbon during experiment
- Percentage of oxygen in air.

46. China dish
(1)

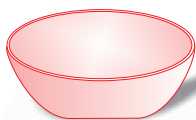

- Heating of chemical during experiment
- As container

47. Wash bottle
(1)

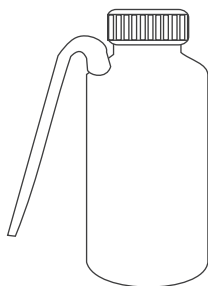

- Used to contain water to wash the apparatus.

48. Generator Assembly (1)

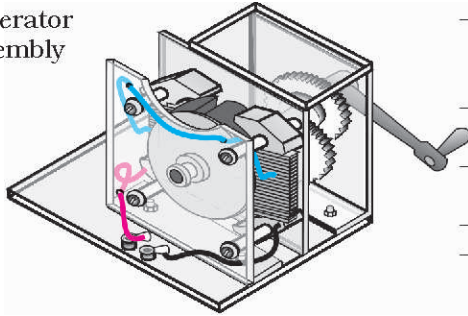

- As mini power house(15V, 500 mA) for experiments.
- To show conversion of energy.
- Lighting bulb for experiment with light.
- Electrolysis of water.
- Experiment with set of resistors.

49. Periscope Frame with mirror (1)

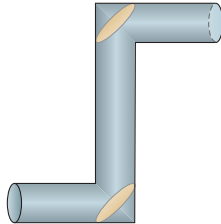

- Used to fit the plane mirror strips and work as Periscope.

50. Plug Key (1)

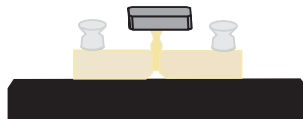

- Used as one way key in an electrical circuit.

51. Crocodile clips (5 set)



- Used as connectors on the circuit board during various electrical activities.

Sl. No.	Item Name (No. of item)	Figure/Setup	Uses
---------	-------------------------	--------------	------

**GENERAL ITEMS
(Category - B)**

1. Rubber bands (assorted size)



- To produce vibration, sound etc.
- Miscellaneous use.

2. Rubber balloons (assorted size)



- To show sound can travel in water.
- Used as diaphragm in expt to show inspiration and expiration.
- Used as improvised pressure detector, miscellaneous use.

3. Cotton thread (1)

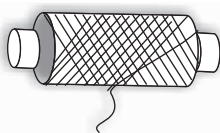

- To show oscillation of simple pendulum.
- Miscellaneous use.

4. Candle (2)

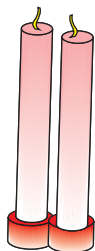

- As a heat source if no alternative available.
- To differentiate between burner and candle flame.

5. Rubber suckers (2)

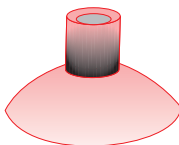

- To show difference of pressure.

6. Forceps (1)



- Used to pick and hold the subject while experimenting.

7. Iron Nails
(assorted size)
(10)

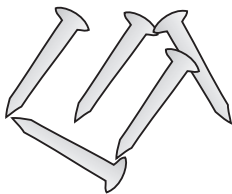

— To test the strength of the magnetic pole of a bar magnet.

8. Test tube brush
(1)



— For collecting and cleaning chemical etc.

9. Test tube holder
(1)

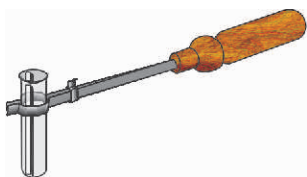

— To hold test tube while performing experiments.
— Heating chemicals during experiments.

10. Polyester cloth
(150 × 150 mm)



— Used for rubbing with balloons/plastic strips to get electric charge.

11. Woolen cloth
(150 × 150 mm)

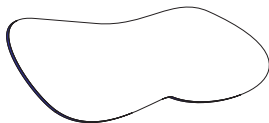

— Used for rubbing with 13 to get electric charge.

12. Thermocolle sheet
(1no.)



— Used as mounting board.
— For experiment with electrostrobe.

13. Plastic strip with
woollen cloth
attached at one side
(100 × 100 mm)
(1)



— To show difference between transparent, translucent and opaques medium.
— To generate static charges.

14. Glazed glass sheet
(100 × 100 mm)
(1)



— Used for mixing dry paste type chemical during experiment.

15. Plane mirror strips (3)

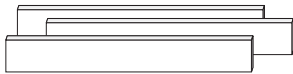

— For preparing Kaleidosope.

16. Copper strip (2 × 10 mm)



— Cu as electrodes for electrolysis.

18. Emery paper (1 piece)



— General use.

22. Sand paper of different numbers (3 pieces)

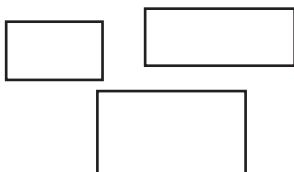

— General use.

23. G-Clamp (1)

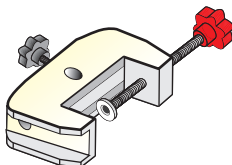

— Used as vice.

24. Lens and spherical mirror stand (1)

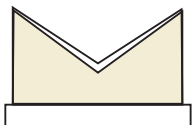

— Used to hold the lens and spherical mirror.

25. Thin rubber sheet (100 × 100 mm) (1 piece)

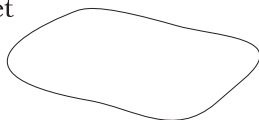

— General use.

TOOL ITEMS

1. Knife
(1)

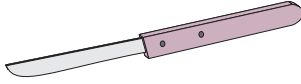

- Used for cutting during experiments
- Used for pruning plants and paper.

2. Surgical scissor
(1)



- Used for cutting thin metal/plastic foil.
- for pruning plants, etc.

3. Screw driver
(1)

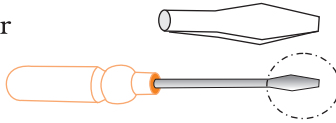

- Used for screwing/Unscrewing.

4. Bottle opener with corkscrew and screwdriver
(1)

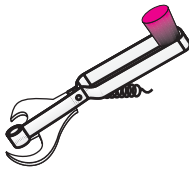

- Used as striker for tuning fork.
- Used as bottle opener.
- As screw driver.

5. Claw hammer
(1)

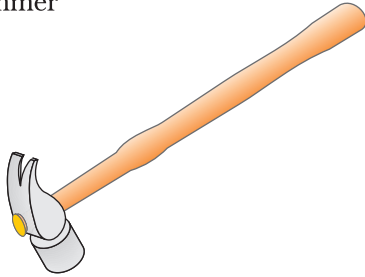

- To remove inserted nails.
- For inserting nails in table/wall.
- For breaking solid chemical.
- To feel hardness/softness of metal.
- To show simple lever.

6. Shaving blade
(1)



- For cutting wax, semisolid chemicals, pruning of plants, etc.

7. Scalpel
(1)



- Used in dissection.

8. Dissecting Needle
(2)

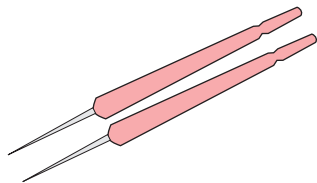

- To point out different parts of biological specimen.
- To pierce paper or any other such item.

9. Pair of tongs
(1)

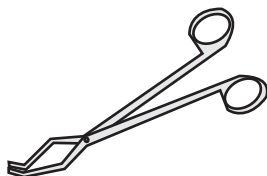

- For holding hot glass rod, test tube, etc. during experiments.

Glass Ware Apparatus and Materials

1. Petridish
(1)



- Used with bell jar for getting distilled water.
- As container.
- Used for germinating seeds.

2. Micro test tube
4/8 mL
(10)

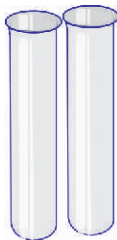

- For experiment requiring heating, holding of chemical etc.

3. Magnifying glass
(1)

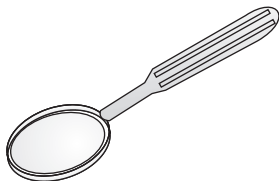

- Used to show magnification.
- To study structure of various chemicals, granules, etc.

4. Beaker
(1)

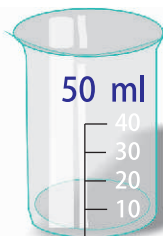

- As container for use in electrochemical experiments, thermochemistry, preparation of salts, etc.

5. Glass Slides (10)

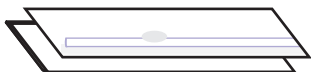

— Used to collect specimen.

6. Y - Tube Borsilicate (1)

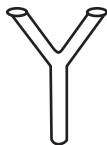

— To show working of lungs.

7. Cover slips (20)

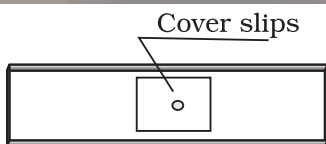

— For covering specimen that is being observed under a microscope.

8. Glass rod (2)



— Used as a stirrer.
— Used to pour liquid on to the filter paper during filtration.

9. Bell Jar (1)

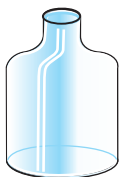

— To show function of lungs.
— To show electrolysis.

10. Double mouthed flask (1)



— To show percentage of oxygen in air.
— To show acid and bases character of non-metals.

11. Glass tube (1)

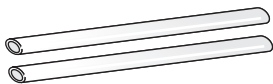

— For miscellaneous use in chemistry experiment.

12. W-Tube (5)

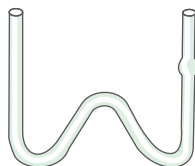

— To test properties of gases.

13. Watch glass
(1)

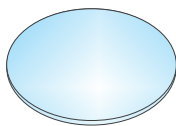

— The watch glass is used to hold solids when being weighed or transported. It should never be heated.

14. Double Concave and Double Convex Lens
(FL 20 cm, dia 50 mm)

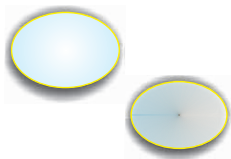

— Used to show the image formation on a screen.

15. Concave and Convex Mirror
(FL 20 cm, dia 50 mm)
(1)

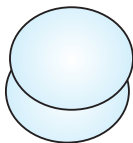

— Used to show the image formation on a screen.

LIST OF CHEMICALS

1. Permanent Slides
 - (i) Hydra showing budding
 - (ii) Amoeba showing binary Fission
 - (iii) Paramecium (1 each)
2. Yeast Powder (10 g)
3. Urea (10 g)
4. Calcium Oxide (10 g)
5. Copper Sulphate (10 g)
6. Sodium Hydroxide (10 g)
7. Methylene Blue Solution (10 mL)
8. Universal Indicator Solution (10 mL)
9. Phenolphthalein (10 g)
10. Magnesium Ribbon (1)
11. Baking Soda (10 g)
12. Sodium Chloride (10 g)
13. Iron Fillings (1 vial)
14. Litmus Paper (Red And Blue)
15. Methylated spirit



**NCERT UPPER PRIMARY
SCIENCE KIT**

Introduction

1. ABOUT THE KIT

The **NCERT Upper Primary Science Kit** with its manual provides various learner-centred activities on the chapters of Science Textbooks for Classes VI, VII and VIII based on new syllabus developed by NCERT. These activities are meant to encourage the students to explore science concepts through their observations and to understand these concepts through various activities/experiments. In order to link the content, the names of the chapters of the textbooks have been mentioned.

The manual describes the activities most of which can be performed using items in the kit. However, some activities may require some items easily available from the surroundings. Each chapter has problem oriented topic (in an interrogative form). In case, you are interested in additional activities, you are at liberty to do those, given in extension activities.

In order to guide your activities, structured performing steps are suggested to facilitate the sequential development of the concepts. Motivational questions on the activity are also suggested. Wherever, required, the answer-clues for some



**NCERT UPPER PRIMARY
SCIENCE KIT**

Introduction

1. ABOUT THE KIT

The **NCERT Upper Primary Science Kit** with its manual provides various learner-centred activities on the chapters of Science Textbooks for Classes VI, VII and VIII based on new syllabus developed by NCERT. These activities are meant to encourage the students to explore science concepts through their observations and to understand these concepts through various activities/experiments. In order to link the content, the names of the chapters of the textbooks have been mentioned.

The manual describes the activities most of which can be performed using items in the kit. However, some activities may require some items easily available from the surroundings. Each chapter has problem oriented topic (in an interrogative form). In case, you are interested in additional activities, you are at liberty to do those, given in extension activities.

In order to guide your activities, structured performing steps are suggested to facilitate the sequential development of the concepts. Motivational questions on the activity are also suggested. Wherever, required, the answer-clues for some

questions are given. Materials required to perform the activity are also suggested.

NCERT *Upper Primary Science Kit* contains scientific and general items, some chemicals, glassware, tools, etc. Attempts have been made to make the items

- Low cost
- Multipurpose
- Microscale

The best examples are W-tube, Y-tube, electric generator, laboratory stand-cum-vice, compound microscope, ray streak apparatus, double mouthed flask, laboratory and clinical thermometer, slinky, sun dial, bimetallic strip, pulley with frame, electric bell, magnetic compass, tuning fork, circuit board, assembly, deflagrating spoon, periscope frame with mirror, belljar for electrolysis, electroscope, lung apparatus, kerosene burner, slides, coils, optics kit, spring balance, micro test tubes, etc.

The Science Kit has the following advantages:

- Availability of necessary piece of apparatus at one place.
- Multipurpose use of items.
- Economy of time in setting up of experiments.
- Portability from one place to another.
- Low cost.

The kit replaces the traditional science laboratory. There has been special provision of use of microscale chemistry lab technique which reduces the wastage of chemicals, hazards and provides pollution free atmosphere, besides other innovative materials.

II. SCIENCE LEARNING APPROACH

There has been a rapid expansion of scientific knowledge in recent years.

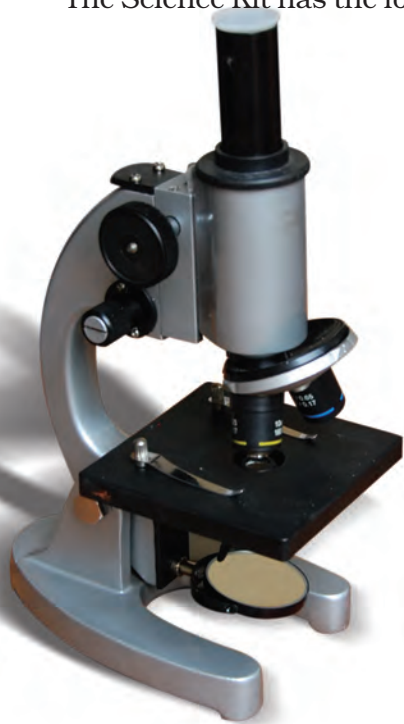

Realisation of the relevance of science education as reflected in human thought, style, social values and culture have been made it imperative to upgrade the curriculum and learning approaches of science in order to improve the quality of life. To make a student (learner) a scientifically literate citizen as envisaged in the National Policy on Education- 1986 and National Curriculum Framework (NCF) 2005, there is an imperative need for the learner to :

- understand and apply the basic concepts of science,
- learn scientific inquiry skills of gathering information,
- develop desirable attitudes and value appreciation for truth and objectivity,
- nurture creative talents,
- learn scientific method and apply it in solving problems and making decisions to improve everyday living and environmental conditions and to promote development and use of technology.

For achieving these objectives, it is necessary to shift emphasis from rote memory-based, content-oriented and teacher-centred method of teaching, to:

- problem solving-based,
- activity-oriented,
- performance-based, and
- learner-centred approaches.

These approaches would require learner to :

- investigate,
- develop observation skills,
- record observations,
- structure, organise and communicate information,
- hypothesise,
- collect and analyse data,
- draw relevant inferences,
- design solutions and act accordingly.

Activity-based learning makes science more interesting, motivating, effective and meaningful. This provides plenty of



opportunity for thinking, reasoning and looking at science in its totality as a highly rational, intellectual problem-solving human activity. This would help in developing qualities like self-confidence, curiosity, initiative, inventiveness, self-reliance, persistence and skills of innovation to solve problems in real life situations. However, to make the best use of the learning situations, it is very essential that the teacher is provided with effective instructional materials in addition to the textbooks. As a teacher you have to plan before hand, outline the general directions and prepare yourself adequately to conduct an investigation. You should read the subject matter from the textbook and this manual. Then, you can make note of scientific ideas, their applications in daily life and the learning processes that may be developed through an investigation. In this manual, an attempt has been made to provide necessary instructional materials containing a description of learner-centred learning experiences or activities. This also includes points of inquiry and necessary experimental skills for conducting the investigation using items from the kit and also based on learner's own experiences from the environment.

The present science learning approach provides a situation where you, as a teacher, have to work not merely as a communicator of scientific knowledge but also as an activity-facilitator and co-investigator. Thus you will also be a co-learner. You should emphasise on activity-based and 'learning science by doing' approaches making use of learner's own experiences and through investigation and problem-solving activities. You should stimulate proper learning situation using the materials that are provided in the science kit. In the learner-centred approach, it is preferable for the students to perform all the activities individually or in small groups. In view of the limited number of the items provided in the science kit, sometimes you may have to conduct experiment/demonstration on some topics for the whole class. You should involve the students in understanding various steps of the activity/demonstration. The proper learning situation facilitates personal investigation/small group activity to conduct the investigation for presentation of results and useful discussions.

This may also help in carrying out project work by the students. Such an approach would discourage rote learning and promote independent thinking among learners. Careful and skilful observation of sequences and steps during an activity is an interesting experience and is a part of the discovery method.

You should ask appropriate questions during the investigation or activities. These questions should help students to become

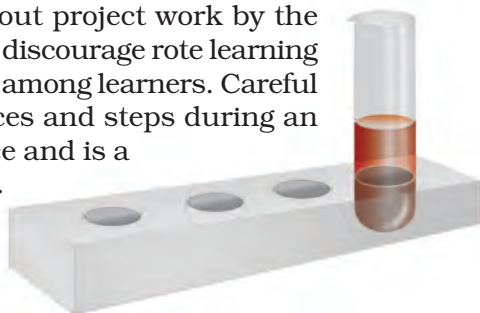

self-confident and independent problem solvers for improving their every day living and environmental conditions, as well as for promoting the use of science and technology.

If an activity does not succeed, do not get discouraged. In such a situation you, along with the student, try to analyse why the activity has not succeeded. A number of ideas may come up for successful performance of the activity. The most reasonable suggestion may then be tried out. If it still does not help, another idea can be tried out till the activity succeeds. By repeating the steps and controlling the procedure during an activity as a method of discovery, the learner is able to understand the whole process more closely, like a budding scientist discovering new ideas or an engineer inventing new solutions to problems or an artists creating new designs.

questions are given. Materials required to perform the activity are also suggested.

NCERT *Upper Primary Science Kit* contains scientific and general items, some chemicals, glassware, tools, etc. Attempts have been made to make the items

- Low cost
- Multipurpose
- Microscale

The best examples are W-tube, Y-tube, electric generator, laboratory stand-cum-vice, compound microscope, ray streak apparatus, double mouthed flask, laboratory and clinical thermometer, slinky, sun dial, bimetallic strip, pulley with frame, electric bell, magnetic compass, tuning fork, circuit board, assembly, deflagrating spoon, periscope frame with mirror, belljar for electrolysis, electroscope, lung apparatus, kerosene burner, slides, coils, optics kit, spring balance, micro test tubes, etc.

The Science Kit has the following advantages:

- Availability of necessary piece of apparatus at one place.
- Multipurpose use of items.
- Economy of time in setting up of experiments.
- Portability from one place to another.
- Low cost.

The kit replaces the traditional science laboratory. There has been special provision of use of microscale chemistry lab technique which reduces the wastage of chemicals, hazards and provides pollution free atmosphere, besides other innovative materials.

II. SCIENCE LEARNING APPROACH

There has been a rapid expansion of scientific knowledge in recent years.

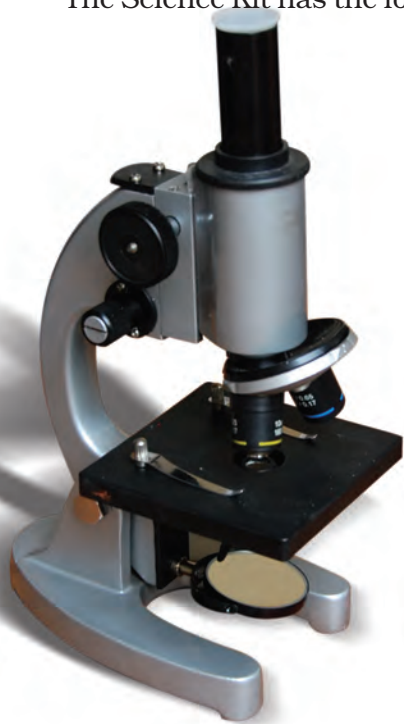

Realisation of the relevance of science education as reflected in human thought, style, social values and culture have been made it imperative to upgrade the curriculum and learning approaches of science in order to improve the quality of life. To make a student (learner) a scientifically literate citizen as envisaged in the National Policy on Education-1986 and National Curriculum Framework (NCF) 2005, there is an imperative need for the learner to :

- understand and apply the basic concepts of science,
- learn scientific inquiry skills of gathering information,
- develop desirable attitudes and value appreciation for truth and objectivity,
- nurture creative talents,
- learn scientific method and apply it in solving problems and making decisions to improve everyday living and environmental conditions and to promote development and use of technology.

For achieving these objectives, it is necessary to shift emphasis from rote memory-based, content-oriented and teacher-centred method of teaching, to:

- problem solving-based,
- activity-oriented,
- performance-based, and
- learner-centred approaches.

These approaches would require learner to :

- investigate,
- develop observation skills,
- record observations,
- structure, organise and communicate information,
- hypothesise,
- collect and analyse data,
- draw relevant inferences,
- design solutions and act accordingly.

Activity-based learning makes science more interesting, motivating, effective and meaningful. This provides plenty of



opportunity for thinking, reasoning and looking at science in its totality as a highly rational, intellectual problem-solving human activity. This would help in developing qualities like self-confidence, curiosity, initiative, inventiveness, self-reliance, persistence and skills of innovation to solve problems in real life situations. However, to make the best use of the learning situations, it is very essential that the teacher is provided with effective instructional materials in addition to the textbooks. As a teacher you have to plan before hand, outline the general directions and prepare yourself adequately to conduct an investigation. You should read the subject matter from the textbook and this manual. Then, you can make note of scientific ideas, their applications in daily life and the learning processes that may be developed through an investigation. In this manual, an attempt has been made to provide necessary instructional materials containing a description of learner-centred learning experiences or activities. This also includes points of inquiry and necessary experimental skills for conducting the investigation using items from the kit and also based on learner's own experiences from the environment.

The present science learning approach provides a situation where you, as a teacher, have to work not merely as a communicator of scientific knowledge but also as an activity-facilitator and co-investigator. Thus you will also be a co-learner. You should emphasise on activity-based and 'learning science by doing' approaches making use of learner's own experiences and through investigation and problem-solving activities. You should stimulate proper learning situation using the materials that are provided in the science kit. In the learner-centred approach, it is preferable for the students to perform all the activities individually or in small groups. In view of the limited number of the items provided in the science kit, sometimes you may have to conduct experiment/demonstration on some topics for the whole class. You should involve the students in understanding various steps of the activity/demonstration. The proper learning situation facilitates personal investigation/small group activity to conduct the investigation for presentation of results and useful discussions.

This may also help in carrying out project work by the students. Such an approach would discourage rote learning and promote independent thinking among learners. Careful and skilful observation of sequences and steps during an activity is an interesting experience and is a part of the discovery method.

You should ask appropriate questions during the investigation or activities. These questions should help students to become

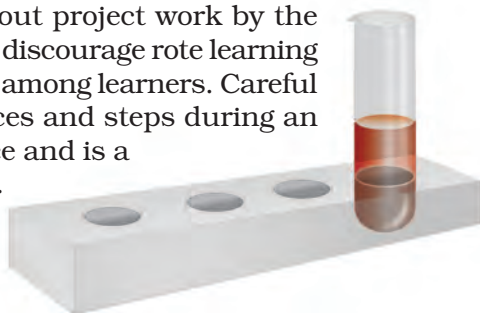

self-confident and independent problem solvers for improving their every day living and environmental conditions, as well as for promoting the use of science and technology.

If an activity does not succeed, do not get discouraged. In such a situation you, along with the student, try to analyse why the activity has not succeeded. A number of ideas may come up for successful performance of the activity. The most reasonable suggestion may then be tried out. If it still does not help, another idea can be tried out till the activity succeeds. By repeating the steps and controlling the procedure during an activity as a method of discovery, the learner is able to understand the whole process more closely, like a budding scientist discovering new ideas or an engineer inventing new solutions to problems or an artists creating new designs.

6.1 FOOD: WHERE DOES IT COME FROM?

ACTIVITY 6.1.1

How to prepare sprouts from whole seeds?

What is required?

Dry whole seeds of gram/ moong, petridish and cotton wool.

How will you proceed?

1. Wash and soak the seeds in water for a day.
2. Drain excess water and leave the soaked seeds overnight in a petridish and cover the seeds with wet cotton.
3. Keep the cotton wet (it should not get dry).
4. After 2-3 days, do you see any new white structures emerging out of the seeds? Name the process involved?



(a)

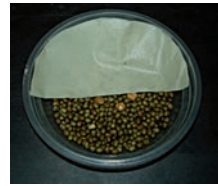

(b)



(c)



(d)

What have you learnt?

The seeds germinate after being kept in moist condition. This is the way a new plant develops from a seed.

Fig.6.1.1
Germination of gram seeds

Extension

- 1. Do all types of seeds form sprouts?*
- 2. Name the conditions required for sprouting.*
- 3. Use the sprouts of moong and gram to prepare a nutritious and tasty snack.*

Notes

6.2 COMPONENTS OF FOOD

ACTIVITY 6.2.1

How can we identify the major components in our food?

How will you proceed?

A . Test for starch

1. Take a test tube and put some crushed potatoes in it.
2. Add few drops of iodine solution in the test tube.

Observation

You will see dark blue black colour. This indicates the presence of starch in potato.

B. Test for protein

1. Take a test tube and put some powdered dal in it.
2. Add 2 drops of copper sulphate solution and 10 drops of caustic soda and shake the test tube.

Observation

You will see a violet colour. This indicates the presence of proteins in dal.

What is required?

Crushed raw potatoes, powdered dal, crushed groundnuts, dilute iodine solution, copper sulphate solution, sodium hydroxide solution (caustic soda), piece of white paper, test tubes and a dropper.

C. Test for fats

1. Take crushed ground nuts in between the folds of a white paper and press them with the help of thumb.

Observation

You will see a translucent patch on the paper at the place where the nuts were pressed.

This indicates the presence of fats (oil).

What have you learnt?

Potato is rich in starch; dal contains proteins and nuts have fat (oil). Thus major components of our food are carbohydrates (starch), proteins and fats.

Extension

Repeat the experiment with powdered rice, powdered gram (besan) or soybean seeds, etc., and fill in the table given below by putting a tick (✓) in the correct place:

Food items	Starch	Protein	fat
Powdered Rice			
Powdered gram			
Powdered soybean seeds			

6.3 FIBRE TO FABRIC

ACTIVITY 6.3.1

How do you identify a fibre?

What is required?

Different types of fibres and a magnifying glass.

How will you proceed?

1. Take three types of yarns of equal size, for example a piece of woollen thread, a piece of cotton thread and a piece of synthetic fibre.
2. Spread them on a sheet of white paper. Observe the yarns through the magnifying glass.
3. Identify the yarn on the basis of size and number of 'burrs'. [See Fig. 6.3.1].

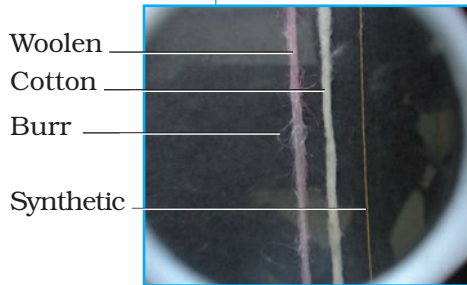
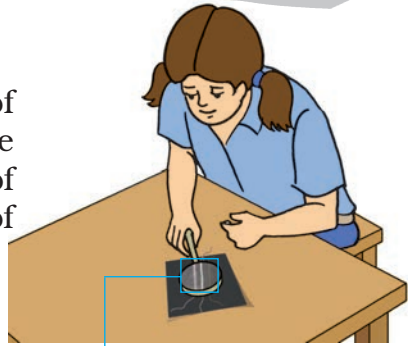

Fig.6.3.1 Different types of fibres

What have you learnt?

Fibres can be identified by their textures. The 'burrs' in wool are the maximum, less in cotton yarn and the least in synthetic yarn. We can use a magnifying glass to see the burrs clearly.

Extension

1. Identification of different yarns by their smell, and the left-over after burning. (*burn the yarns very carefully*).

Sample	Smell	Characteristics of left-over after burning
A		
B		
C		

2. Check for absorption of water by different types of fibres.

Notes

6.4 SORTING MATERIALS INTO GROUPS

ACTIVITY 6.4.1

How do you classify materials/objects on the basis of their appearance?

What is required?

sand paper, card board, piece of wood, copper wire, aluminium sheet, chalk, medicine wrappers, iron nails, zinc pieces and magnesium ribbon.

How will you proceed?

1. Observe each of the above materials and note which of them have shiny surface.
2. Take an iron nail and rub it properly with the sand paper. Does the freshly rubbed surface appear shiny?
3. Repeat the same procedure with other materials. Why do we need to rub the surface of materials?
4. Classify these materials as *lustrous* or *non-lustrous materials* i.e., shiny and non-shiny in appearance.

Sl. No	Object	Lustrous (shiny)	Non-lustrous (non-shiny)
1.			
2.			
3.			
4.			
5.			
6.			
7.			
8.			

What have you learnt?

- 1. Freshly cut/rubbed surfaces of some materials have shiny appearance i.e. they have lustre.*
- 2. The materials which have lustre are copper wire, aluminium sheet, medicine wrappers, iron nails, zinc pieces and magnesium ribbon and those without lustre are card board, piece of wood and chalk.*

Extension

Try to classify some more materials/objects on the basis of their appearance.

Notes

ACTIVITY 6.4.2

Do substances dissolve in water?

What is required?

sugar, salt, chalk powder, sand, saw dust, test tubes, spatula and wash bottle.

How will you proceed?

1. Take some test tubes.
2. Fill each of them up to one-fourth with water.
3. Add a spatula full of any one substance in one of the test tubes and shake it. Observe what happens.
4. Similarly, add small amounts of the other substances in the remaining test tubes and shake them.
5. Which substances disappear or dissolve in water and which substances do not disappear or dissolve?
6. Separately list the substances which dissolve in water and the ones which do not dissolve.

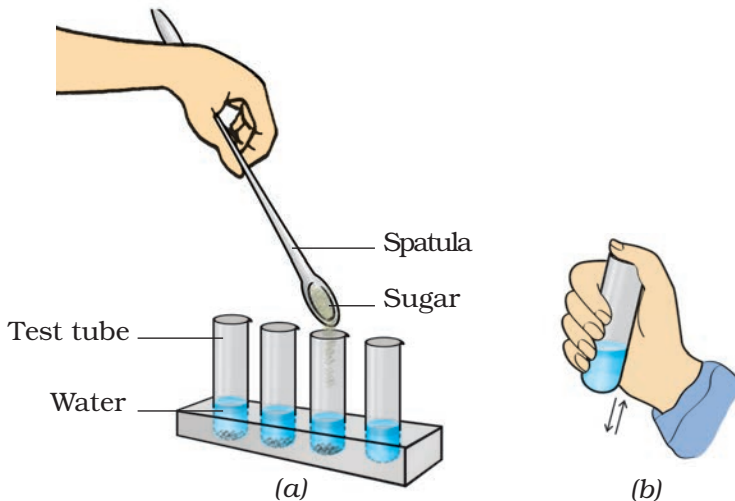

Fig.6.4.2 Finding solubility of different substances in water

What have you learnt?

- 1. Some substances dissolve in water while others do not.*
- 2. Substances like sugar and salt which disappear or dissolve in water, are called **water-soluble**.*
- 3. Substances like chalk powder, sand and saw dust which do not disappear / dissolve in water are called **water-insoluble**.*

Extension

Check the solubility of glucose, starch, wheat flour, iron filings, etc. in water and classify them as water soluble or insoluble.

Notes

ACTIVITY 6.4.3

What happens when other liquids are added to water?

What is required?

Vinegar, Lemon juice, alcohol, mustard oil, coconut oil, cooking oil, kerosene, test tubes, dropper, wash bottle.

How will you proceed?

1. Take few test tubes.
2. Take equal volume of water in each of them i.e., fill each of them approximately $\frac{1}{3}$ rd with water.
3. Add a few drops of oil with a dropper in one of the test tubes [Fig.6.4.3 (a)].
4. Similarly, add different liquids to different test tubes containing water [Fig.6.4.3 (b)].
5. Shake the test tubes well and observe them after sometime.
6. You can see that the liquids either mix with water well or do not mix and form a separate layer [Fig. 6.4.3(a) and (b)].

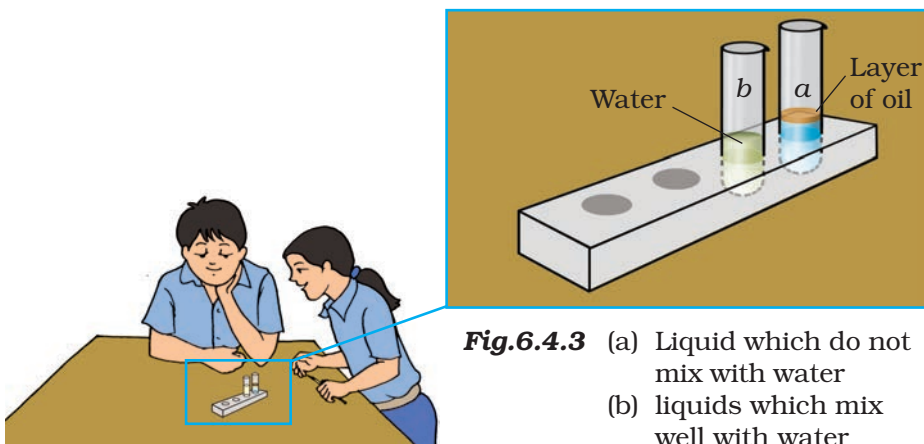

Fig.6.4.3 (a) Liquid which do not mix with water
(b) liquids which mix well with water

7. Make a list of the liquids which mix well with water and others which do not mix with water.

What have you learnt?

Some liquids completely mix with water while some others do not. Liquids like vinegar, lemon juice and alcohol that mix with water are soluble in water (miscible) and liquids that do not mix with water like mustard oil, cooking oil, coconut oil and kerosene are said to be insoluble in water (immiscible).

Notes

ACTIVITY 6.4.4

Can you see through materials?

What is required?

A piece of wood, a piece of glass, different plastic sheets, a piece of cardboard, white paper, oil, cotton, pencil, a flower, source of light, test tube, light or electric bulb, iron nails.

How will you proceed?

1. Take each of the above materials one by one and try to see through them.
2. You can do this by placing a pencil or an iron nail behind each one of these materials and try to see it.
3. Can you see through them?
4. List the materials through which you could see and through which you could not see.
5. Take a white paper.
6. Hold the iron nail behind the paper and try to see through it.

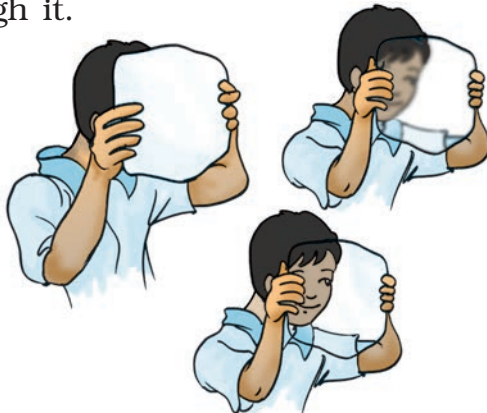

Fig.6.4.4 *Distinguishing among opaque, transparent and translucent object*

7. Are you able to see the iron nail through the paper?
8. Now put 2-3 drops of oil and smear with the help of a cotton plug so that the oil occupies a larger area.
9. Now try to see the nail through this paper.
10. What do you see? Can you now see the nail?

What have you learnt?

1. *Some materials through which we cannot see are called **opaque** while other materials through which we can see clearly are called **transparent**.*
2. *Some other materials through which one cannot see clearly, are called **translucent**.*
3. *Oiled paper is translucent and we can see partially through the translucent materials.*

Extension

*Take some more materials like coloured glass, plastic sheets, coloured paper sheets etc., and classify them as **opaque**, **transparent** or **translucent**.*

6.5 SEPARATION OF SUBSTANCES

ACTIVITY 6.5.1

How will you separate mud from muddy water?

What is required?

Three beakers, funnel, filter paper, fine cloth, tripod stand.

How will you proceed?

1. Take some muddy water in a beaker.
2. Leave it undisturbed for some time till the mud settles down [Fig.6.5.1 (a)]. What is this process called?
3. Pour the water above mud by tilting the beaker gently into another beaker [Fig.6.5.1 (b)]. What is this process called? Is the water poured in second beaker clear?

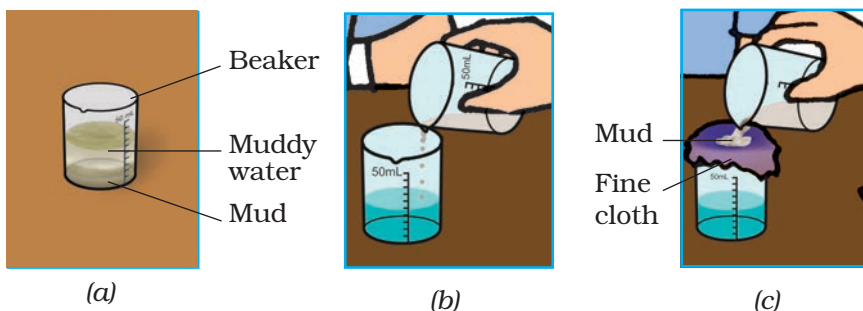
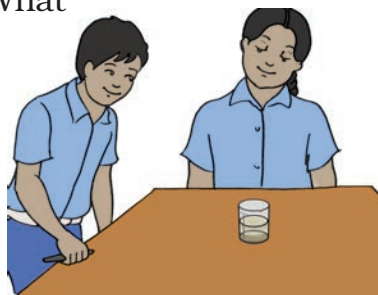

Fig.6.5.1 (a) Sedimentation of mud
(b) Decantation of mud
(c) Filtration of mud

If no, what will you do to get clear water? You can proceed as given below.

4. Take a fine cloth and gently pour the water through it into a third beaker [Fig. 6.5.1 (c)]

Is the water which is obtained in the third beaker clear?

5. If not, what will you suggest to get the clear water? You can proceed further as given in step 6.

6. Pour the water through a filter paper folded in the form of a cone kept in a funnel [Fig.6.5.1 (d)].

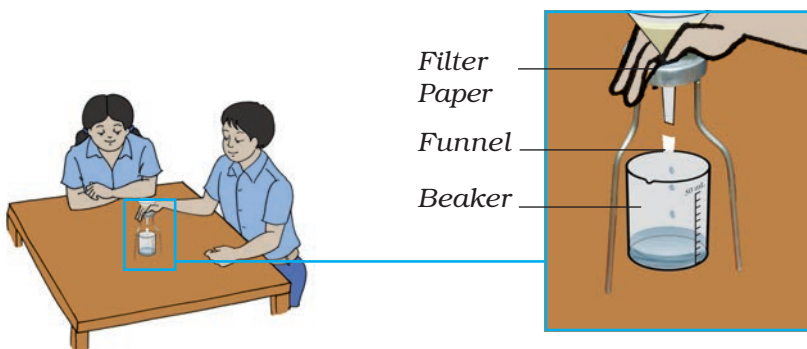

Fig.6.5.1 (d) Filtration of mud from muddy water

How to fold the filter paper? You can follow the steps which are shown below [Fig. 6.5.1 (e)].

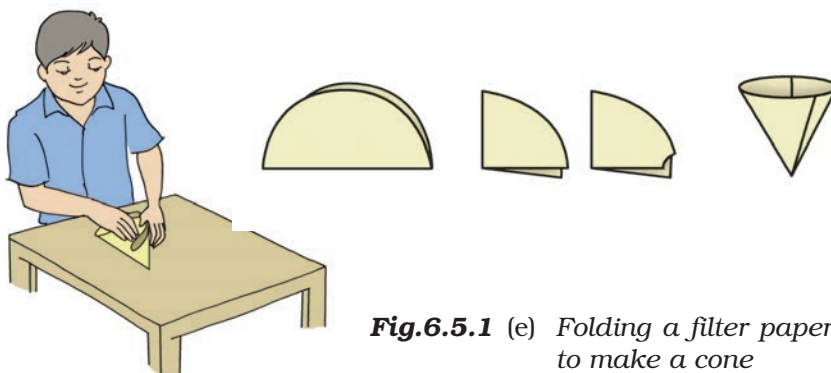

Fig.6.5.1 (e) Folding a filter paper to make a cone

What have you learnt?

*In a mixture of water and a solid, the heavier particles get settled. The water above the settled particles can be removed. In order to further remove the finer particles, a cloth or a filter paper can be used. Mud can be separated from muddy water by **sedimentation**, **decantation** and **filtration** to give the clear water.*

Extension

Think of some more mixtures where these techniques can be used for separation.

Notes

ACTIVITY 6.5.2

How will you separate salt from salt solution?

What is required?

Kerosene burner, beaker, China dish, common salt, water.

How will you proceed?

1. Take a spatula full of common salt and transfer it into a beaker.

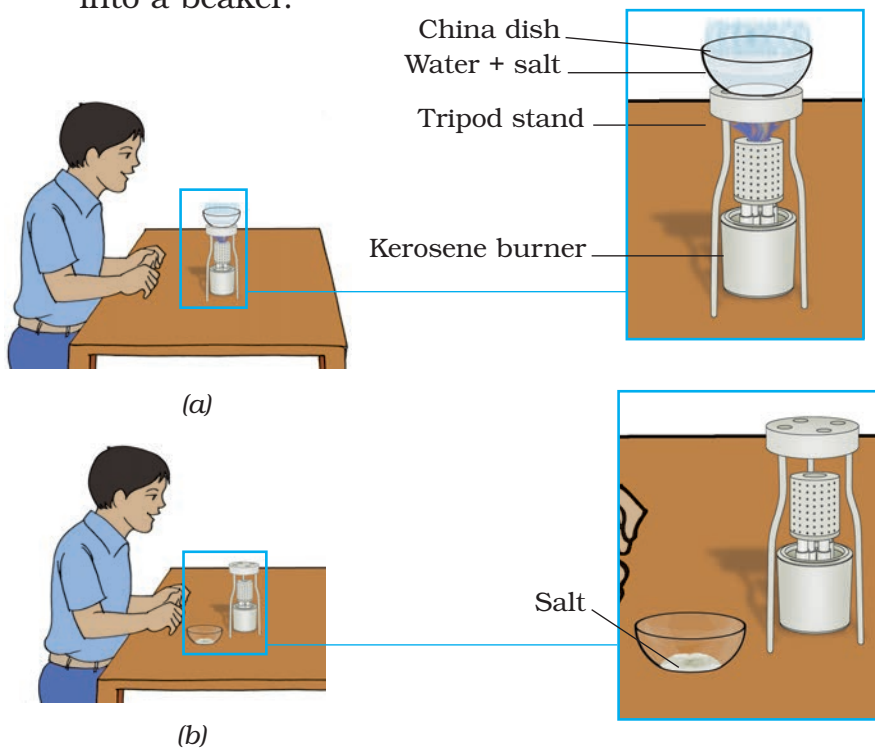

Fig.6.5.2 Separation of salt from salty water

2. Dissolve it in the minimum amount of water to prepare the salt solution.
3. Take a small quantity of this solution in a China dish.

4. Heat the China dish containing salt solution on a kerosene burner [Fig.6.5.2(a)].
5. Do you see any change in the volume of solution?
6. Keep heating till all the water evaporates.
7. What is left behind in the China dish? [Fig.6.5.2(b)].
What about its quantity?

What have you learnt?

1. *When the salt solution is heated, water gets evaporated leaving behind the salt.*
2. *Salt from the salt solution can be obtained by evaporation of water.*

Extension

Think of some more substances which can be obtained by evaporation of their solutions. Repeat this activity with these substances also.

Activity 6.5.3

How will you separate a mixture of sand and salt?

What is required?

Sand, salt, water, beaker, China dish, tripod stand, kerosene burner, wash bottle, glass rod.

How will you proceed?

1. Take a mixture of sand and salt in a beaker and add some water. Why is water added to the mixture?
2. Now stir the contents with a glass rod [Fig.6.5.3 (a)].
3. Leave them undisturbed for some time. What do you see? [Fig. 6.5.3 (b)].
4. Decant the liquid from the beaker to a China dish [Fig.6.5.3 (c)].
5. Heat the liquid in the China dish over a kerosene burner. The water will start evaporating [Fig.6.5.3 (d)].
6. What will be left in the China dish after all the water has evaporated?

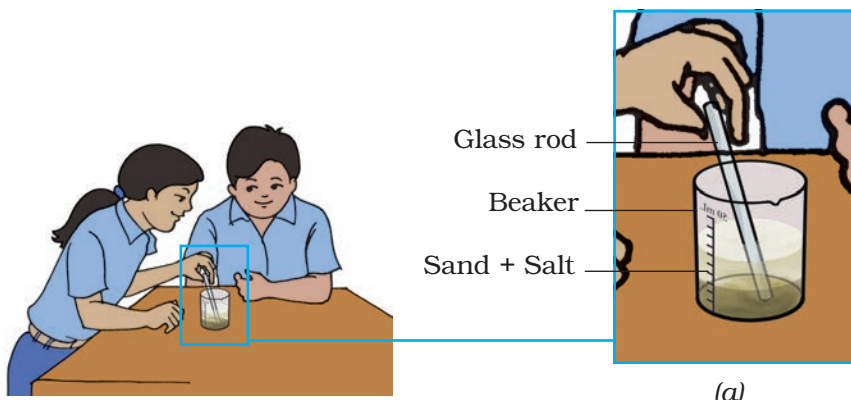

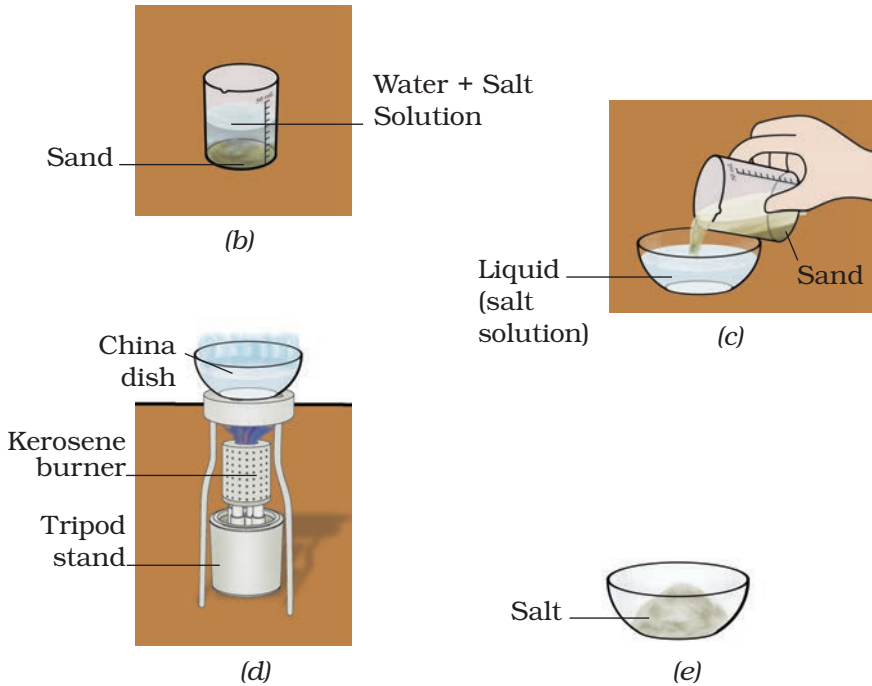

Fig.6.5.3 (a) Mixture of sand water
 (b) Sedimentation of sand
 (c) Decantation of salty water
 (d) Evaporation of water
 (e) Salt after evaporation

What have you learnt?

1. *salt is soluble in water whereas sand is insoluble.*
2. *When water is added to the mixture of sand and salt, sand being heavier than water, settles down.*
3. *The mixture of sand and salt can be separated by decantation and evaporation.*

ACTIVITY 6.5.4

Can a given volume of water dissolve any amount of a substance?

What is required?
Salt, water, beaker,
spatula, glass rod.

How will you proceed?

1. Take a 50 mL beaker and half fill with water.
2. Add a spatula full of salt to it and stir it well.
3. Does the salt disappear?
4. Add little more of the salt into it and stir again.
What happens now?
5. Keep on adding the salt with continuous stirring till the salt stops disappearing (dissolving).
6. What will happen if you add some more salt? Does it dissolve?

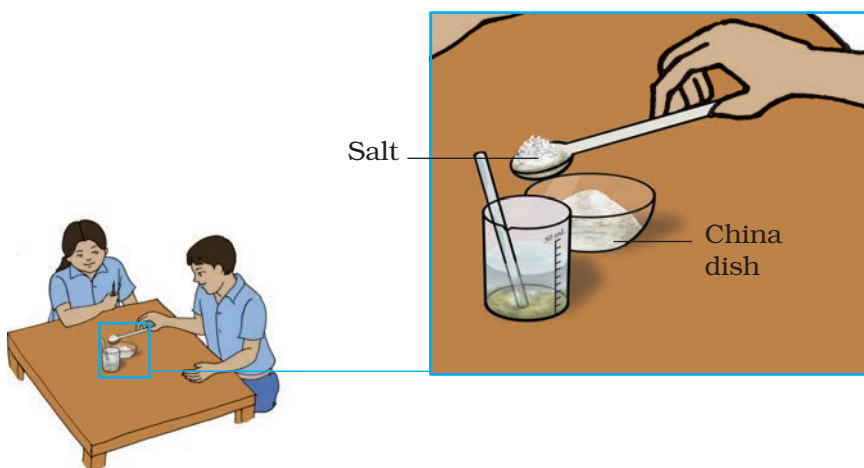

Fig.6.5.4 Salt dissolves in water at room temperature

What have you learnt?

A given amount of water dissolves only a definite amount of a substance (salt) at a given temperature. The solution so obtained is called a saturated solution.

Extension

- 1. Add some water to the saturated solution containing some undissolved salt and stir.*
- 2. What do you observe?*

Notes

ACTIVITY 6.5.5

How can a saturated solution be made to dissolve some more substance?

*What is required?
salt, beaker,
spatula, glass rod,
kerosene burner.*

How will you proceed?

1. In a beaker take the saturated solution of salt as prepared in the previous activity.
2. Is there some way that saturated solution could be made to dissolve more salt?
3. Add a small quantity of salt and heat the beaker over the kerosene burner [Fig.6.5.5].
4. What do you observe? Has the added salt disappeared?
5. If you see that the added salt has disappeared, add some more salt.
6. What happens now ?

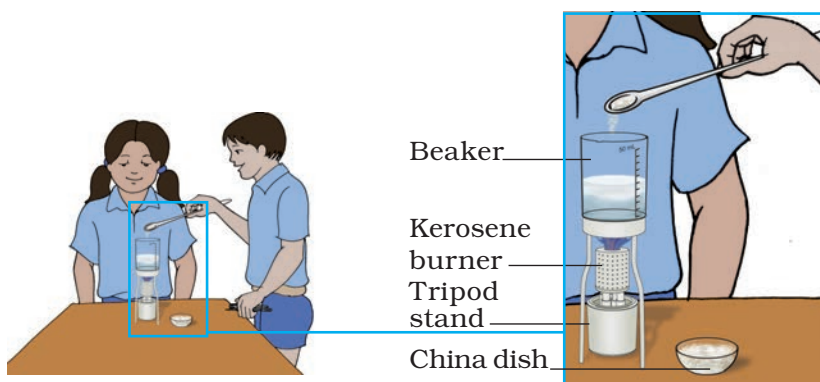

Fig.6.5.5 Amount of dissolvable salt increases in hot water

What have you learnt?

Some more amount of a substance can be made to dissolve in the saturated solution by heating it.

Extension

Try to dissolve the copper sulphate into its saturated solution.

Notes

ACTIVITY 6.5.6

Are different substances dissolved in varying quantities in water?

What is required?

Common salt, sugar, spatula, test tubes.

How will you proceed?

1. Take a test tube and fill it up to one-fourth with water.
2. With the help of a spatula, add common salt to the test tube.
3. Shake the test tube well to dissolve the salt.
4. Keep adding salt using a spatula till you get a saturated solution. Also count the number of times the salt is added to get the saturated salt solution.
5. Repeat the above procedure using sugar.
6. Are the amounts of salt and sugar required to form their saturated solutions the same?

What have you learnt?

Different substances dissolve to different extent in equal volumes of water.

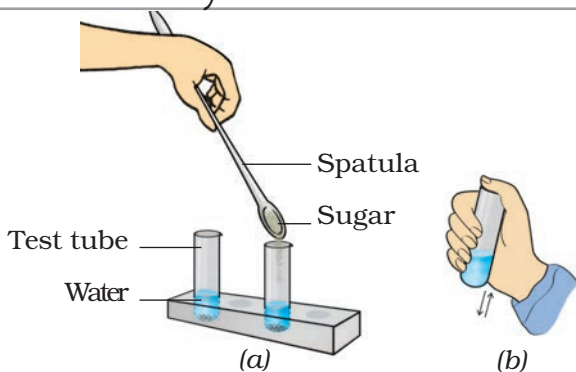

Fig.6.5.6 *Different substances dissolved in varying quantities in equal volume of water*

6.6 CHANGES AROUND US

ACTIVITY 6.6.1

Can you identify some changes which can be reversed?

What is required?

Balloon, rubber band.

How will you proceed?

Part A

1. Take a rubber band. Observe its shape and size [Fig.6.6.1(a)].
2. Can you change its shape or size?
3. Stretch it. What do you observe? [Fig.6.6.1(b)].
4. Now release it. Does it regain its shape and size?

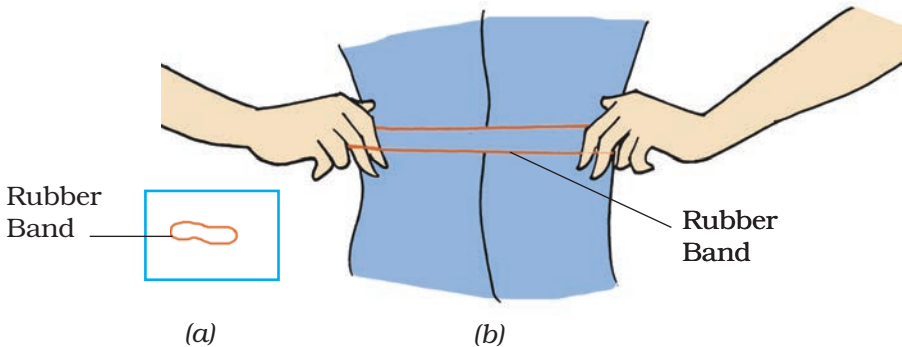

Fig.6.6.1 (i) Reversible change

Part B

1. Now take a balloon. Observe its shape and size.
2. Can you change its shape and size? How?
3. Inflate the balloon. Observe its shape and size.
4. Now release the air from the balloon. Does it regain its original shape and size?

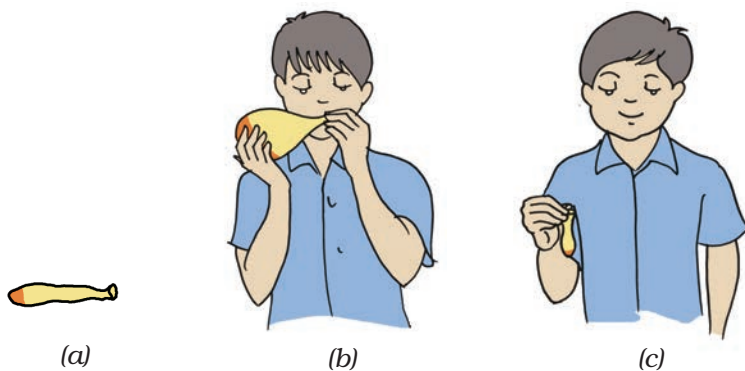

Fig.6.6.1 (ii) Reversible change

What have you learnt?

We can get back the same shape and size of some objects. So we understand that some changes can be reversed.

Extension

- 1. Observe the balloon-seller making different types of toys, e.g., cat, monkey etc., from the big balloon.*
- 2. Do you observe any change in size only or shape only or both of these in the balloon from which the toy is made?*

ACTIVITY 6.6.2

Can you explain the difference between changes which can be reversed and those which cannot be reversed?

What is required?

Two square sheets of paper of same size, scissors.

How will you proceed?

1. Take a sheet of paper and fold it to make an aeroplane. Do you observe any change in its shape and size?
2. Now unfold it and observe its shape and size. Does the paper regain its original shape and size?

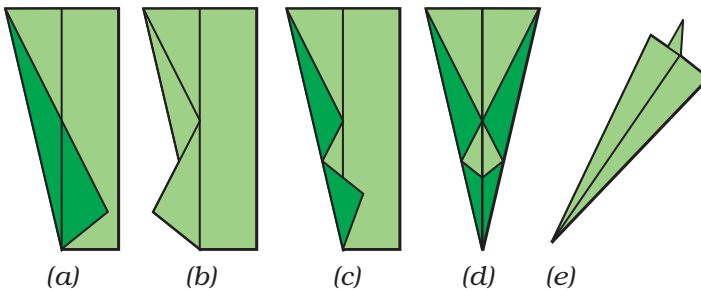

Fig.6.6.2 (i) A toy aeroplane made by folding paper

3. Take the other sheet of paper and cut it into four equal parts.
4. Observe the size of all the parts.
5. Can you get back the original size of sheet of paper again?



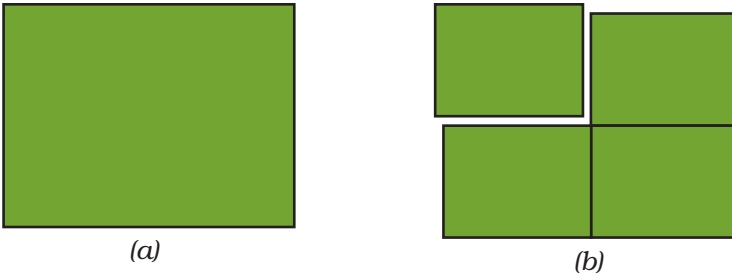

Fig.6.6.2 (ii) (a) Plane sheet of paper
(b) Sheet divided into four equal parts

What have you learnt?

Some changes can be reversed while some others cannot be reversed.

Extension

Try to make different paper toys by folding and cutting and then observe which type of change is reversed.

ACTIVITY 6.6.3

Are 'burning of candle' and 'melting of wax' changes of the same type?

What is required?

A candle, a match box, a test tube, some wax and a scale.

How will you proceed?

Part A

1. Take a candle and measure its length with a scale Fig.6.6.3 (i).
2. Now light the candle and let it burn for sometime.
3. Can this change be reversed?
4. Now measure the length of the candle again. Can you get the candle of same length again?

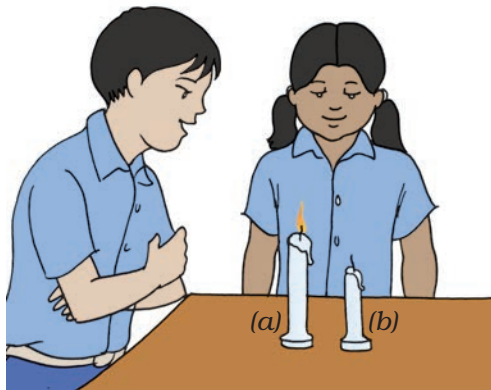

Fig.6.6.3 (i) Non-reversible change

Part B

1. Take some wax in a test tube.
2. Heat the wax in the test tube till it melts completely [Fig.6.6.3 (ii)].
3. Now let the wax cool down.
5. What do you observe?

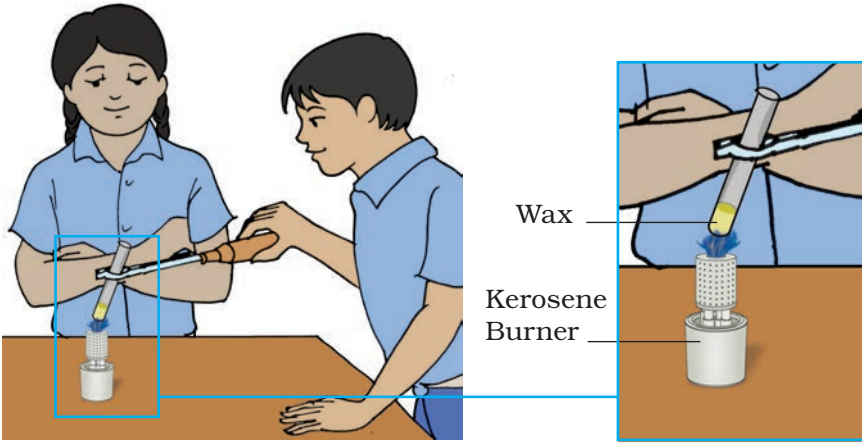

Fig.6.6.3 (ii) Reversible change

What have you learnt?

The candle of same length cannot be obtained again
i.e., change in length of candle cannot be reversed .

Hence, burning of candle is not reversible but melting
of wax is reversible.

Notes

6.7 GETTING TO KNOW PLANTS

ACTIVITY 6.7.1

Why does the colour of white petals of a flower change when a flowering twig is dipped in some coloured solution?

How will you proceed?

1. Fill one third of a tumbler with coloured (red/blue) water.
2. Give an oblique cut to a white flowering twig and put it in the beaker for 3 - 4 hours.
3. Keep this set-up in an open space in bright sunlight.
4. Do you observe any change in the colour of the petals of the flower?

What is required?

A white flowering twig of balsam or chandini plant, coloured ink (blue/red), a tumbler, a magnifying glass and a blade .

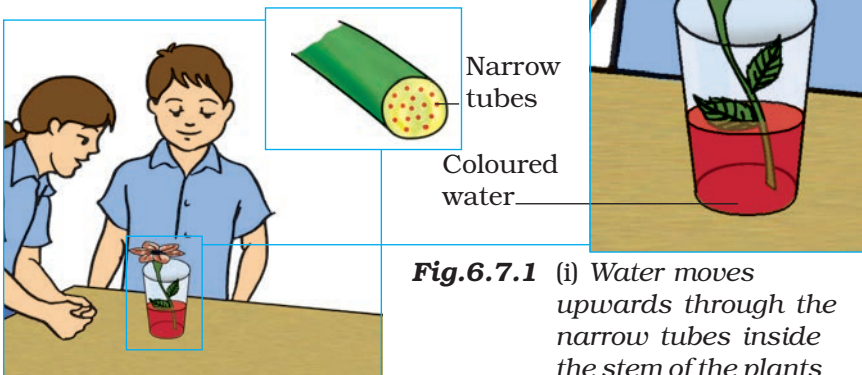

Fig.6.7.1 (i) Water moves upwards through the narrow tubes inside the stem of the plants

5. Is there any resemblance between the colour of the petals and the solution?
6. Now cut the twig across and observe the colour inside with the help of a magnifying glass.

What have you learnt?

The stem of the twig contains narrow tubes (special cells) for transportation of water and minerals to other parts of the plant.

Extension

Take another white flowering twig and split it halfway along its length and put one of the split ends in tumbler containing red coloured solution [Fig (a)] and the other end into the tumbler containing blue coloured solution [Fig (b)]

What do you observe after 3-4 hours?

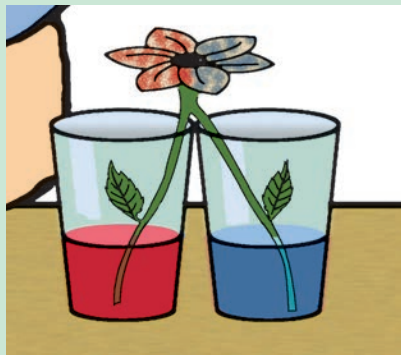

Fig.6.7.1 (ii) Water moves upwards through special tissues (xylem) of the plants

ACTIVITY 6.7.2

How to study the venation patterns in leaves?

What is required?

Leaves of plants like peepal, rose, banana, bamboo, kaner, wheat, maize, mango, lemon, balsam, etc., a magnifying glass and old newspapers.

How will you proceed?

1. Take leaves of plants like peepal, rose, banana, bamboo, kaner, wheat, maize, mango, lemon and balsam.
2. Put each and every leaf separately between the folds of newspaper, and place thick heavy books over them.
3. Turn the leaves upside down daily, and if possible, change the newspaper, so as to avoid fungal infection. Take out all the leaves after a week. Now hold leaves one by one between your thumb and forefinger and study their venation. You can take the help of a magnifying glass, if needed. Fill in the table given below by writing the type of venation found in different leaves.

Sl.No.	Leaf	Type of venation
1.	Peepal	
2.	Rose	
3.	Banana	
4.	Bamboo	
5.	Kaner	
6.	Wheat	
7.	Maize	
8.	Mango	
9.	Lemon	
10.	Balsam	

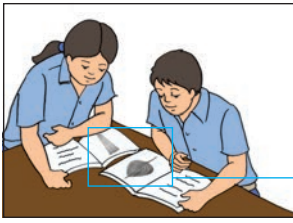

Parallel
venation

Reticulate
venation

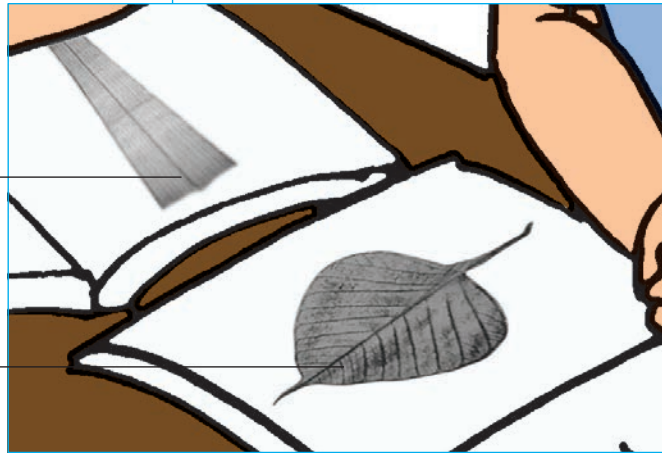

Fig.6.7.2 Two types of leaf venation

What have you learnt?

- 1. The leaves have lines all over its lamina. These lines are called veins. The pattern of these veins differs in the leaves of different plants.*
- 2. Some leaves have veins running parallel to each other (as in wheat/grass). Such a venation is called **parallel venation**. While others have interconnected veins forming a net like structure (like leaves of peepal, rose; etc.). This is called **reticulate venation**.*

Extension

1. Place the leaves of peepal in water for about a week. Take them out and put these in between the folds of newspapers and press them by putting some weight over them. After a few days take them out. You can make your innovative cards by using these decorative leaves.

Notes

Note: While plucking leaves, please try to be considerate. Do not pluck extra leaf.

ACTIVITY 6.7.3

How to study transpiration in plants?

What is required?

Potted plant, transparent polythene bags and thread.

How will you proceed?

1. Take a medium size and well watered plant.
2. Remove all the leaves of one twig of this plant.
3. Now take two polythene bags. With one bag cover this twig and with the other cover any other twig in which the leaves are intact.
4. Tie the mouths of the two bags around the bases of the two twigs.
5. Leave the plant in sunlight for an hour or two.
6. Drops of water will appear on the inner side of the bag that covered the leafy twig.
7. No water drops will be seen on the inner side of the bag over the twig without leaves.

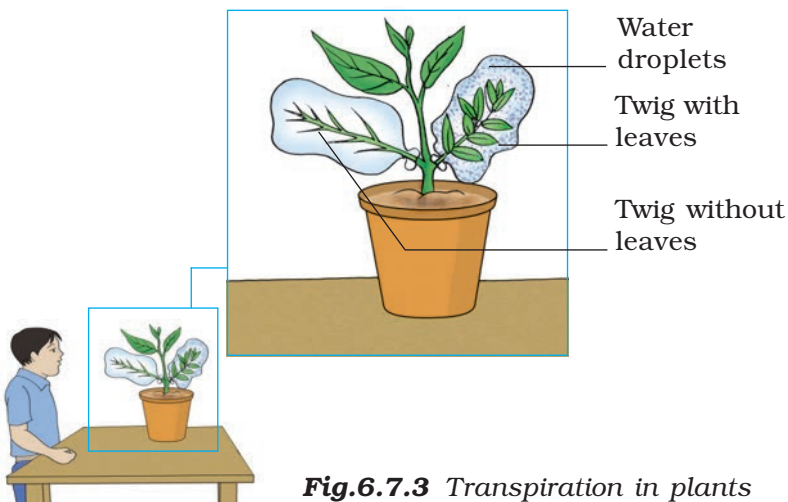

Fig.6.7.3 Transpiration in plants

What have you learnt?

- 1. The droplets of water appeared inside the polythene bag that covered the leafy twig.*
- 2. These droplets are the condensed form of water vapours released during transpiration by the plants.*
- 3. Plants release water into the atmosphere in the form of water vapours through their leaves. This process is called transpiration.*

Extension

Repeat the above activity on a cloudy day.

Notes

ACTIVITY 6.7.4

Why leaves are called the kitchen of the plant?

What is required?

Potted plant, black paper, beaker, tripod stand, kerosene burner, iodine solution, water, petridish and methylated spirit.

How will you proceed?

1. Destarch the leaves of a plant by keeping the plant in a dark room for about a few days.
2. Cover one of its leaves with black paper on which a design of a star is cut.
3. Now place this plant in the sun.
4. Dip the leaf which was covered by black paper in boiling water for a minute to burst open the cells, and to remove the entire chlorophyll.
5. Now transfer the leaf in a test tube with methylated spirit. Put this test tube in a beaker filled with water.
6. Boil the water in the beaker over a burner. The leaf will become brittle and hard.

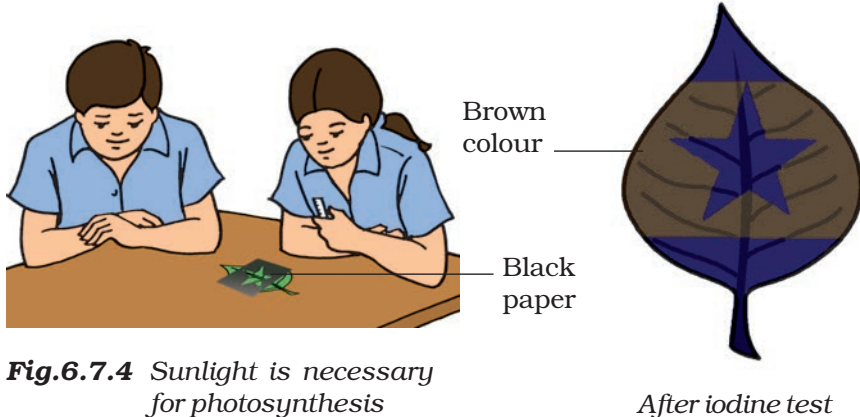

Fig.6.7.4 Sunlight is necessary for photosynthesis

After iodine test

7. Place the leaf again in hot water to soften it.
8. Spread the leaf in a petridish and pour iodine solution on it.

Observation

Only those parts of the leaf which were not covered by the paper, show the presence of starch. It is because only the cut-out design could get the sunlight and prepared the starch in the presence of light.

What have you learnt?

The portions of leaf not covered with black paper synthesised food (starch) in the presence of sunlight due to which the colour of leaf turned blue, black in the presence of iodine.

Extension

Repeat the experiment with a variegated leaf.

Activity 6.7.5

What are the major types of roots?

What is required?

Grass and small herbaceous (mustard / Amaranthus) plants.

How will you proceed?

1. Dig out a small herbaceous plant and any grass from the ground.
2. Wash the soil of the roots and observe the roots.
3. What do these roots look like? Are they similar or different?

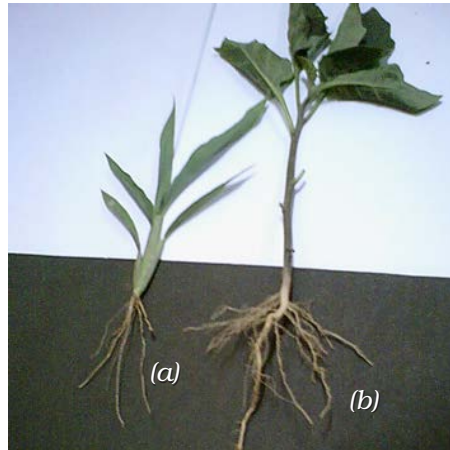

Fig.6.7.5 (a) Tap root
(b) Fibrous root

What have you learnt?

1. There are two major types of root system - tap root and fibrous root.
2. Some plants have roots which consist of a main root with side branches (Tap roots).
3. There are some other plants which do not have any main root and all the roots originate directly from the base of the stem (Fibrous roots).

4. Amaranths has tap roots.

5. Grass has fibrous roots.

Extension

1. You have learnt that the leaves of some plants have a parallel venation, while others have a reticulate venation. Venation of leaves is correlated with the type of roots these plants have. Some common plants are given in the following table. Fill in the table given below by writing the type of venation and roots each plant possesses:

Sl.No.	Plants	Type of venation	Type of root
1.	Mooli		
2.	Gram		
3.	Meethi		
4.	Maize		
5.	Pudina		
6.	Bathuaia		
7.	Dhania		

2. Visit your nearby garden and observe the plants and trees. Differentiate between herbs/ shrubs and trees. Observe the type of venation in all these plants' leaves.

ACTIVITY 6.7.6

What are the functions of roots?

What is required?

Any two herbaceous plants, two pots with soil, blade, and water.

How will you proceed?

1. Select two herbaceous plants of the same kind from ground and dig them out taking care that the roots do not break.
2. Put one plant in soil in the pot labelled as A (Fig. 6.7.6.
3. Cut off the roots from the other plant and fix it in soil in the pot B.
4. Water them regularly and observe the plants after a week.

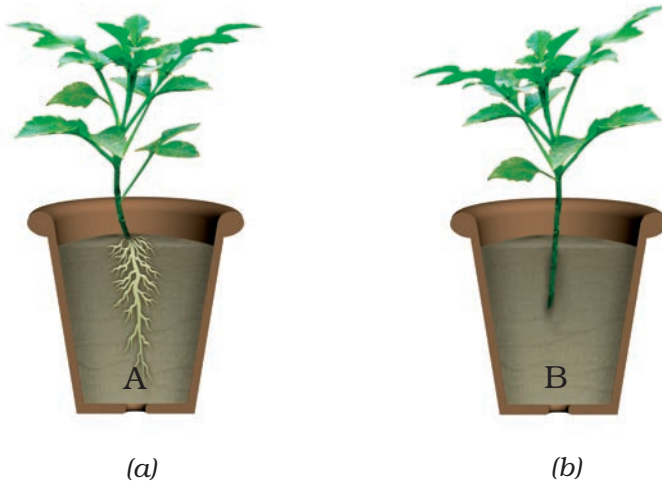

Fig.6.7.6. (a) Growing of the plant in soil with its root
(b) Plants in soil without roots

What have you learnt?

- 1. Plant in pot A will continue to stand erect, and it is difficult to pull it out as the roots help in providing anchorage.*
- 2. Plant in pot B will not stand erect and will fall and it is easier to pull it out.*
- 3. The plant in pot A shows normal growth and development as roots also help in the absorption of water and minerals.*
- 4. The plant in pot B will die as there are no roots.*

Extension

Observe the roots of carrots, banyan tree, sugar cane and moneyplant, and comment on their other functions.

6.8 MOTION AND MEASUREMENT OF DISTANCES

ACTIVITY 6.8.1

How can we recognise periodic motion and circular motion?

What is required?

Pendulum bob, thread (1 metre), wrist watch or stop watch, G-clamp and iron rod.

How will you proceed?

1. Fix the G-clamp at the edge of a table. Insert the iron rod in the hole of G-clamp such that about 10-15 cm length of the rod should be projected outside and tighten the screw [Fig. 6.8.1 (a)].
2. Tie a thread to the hook of the bob.
3. To make a pendulum, suspend the bob with the help of the thread from the rigid projecting iron rod.
4. When the bob is stationary, displace it a little from its initial position O to the new position A and then release.
5. Observe its motion.
6. What type of motion is it? Let us find out.
7. Note the time for 10 complete swings, i.e. motion along AOB and back along BOA of the pendulum.

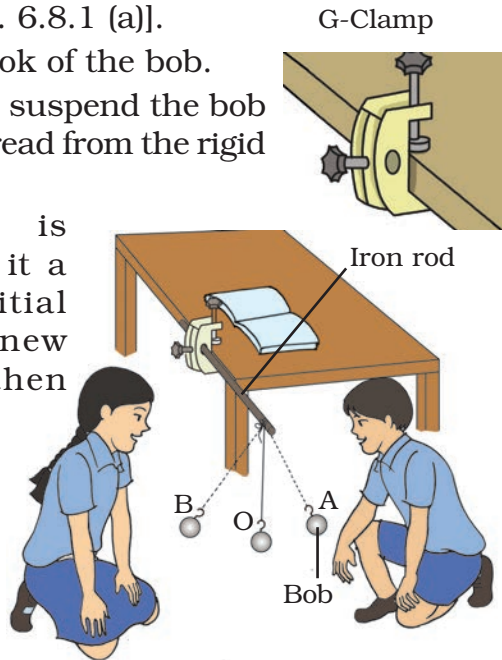

Fig.6.8.1 (a) The motion of a simple pendulum

8. Repeat the step No. 7 three times.
9. Is the time taken for 10 swings the same in each case?
10. If the time taken is the same in each case, it means that pendulum repeats its motion after a fixed interval of time. So we can say that the motion of the pendulum is periodic.
11. Now move the bob in such a way that it moves in a horizontal circular path [Fig. 6.8.1(b)].

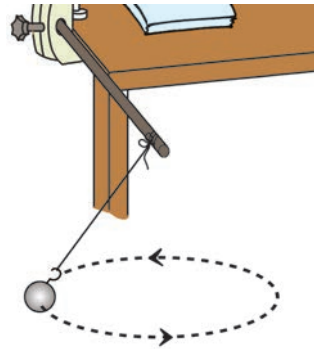

Fig.6.8.1
(b) The circular motion of the bob

12. What type of motion does the bob show now?
13. Should we call this motion as circular motion? Discuss.

What have you learnt?

1. Motion is said to be periodic if an object repeats its motion after a fixed interval of time.
2. If a body moves in a circle, then it is said to be in circular motion.

Extension

1. Observe different motions around you and classify them as periodic and non-periodic.
2. Verify whether circular motion of the bob of the pendulum is periodic or not.
3. Also observe some objects making circular motions which are not periodic.

ACTIVITY 6.8.2

How can we measure the perimeter of a circular object using a thread?

What is required?

Cotton thread, bangle, scale or measuring tape, pencil and paper.

How will you proceed?

1. Keep the bangle on a sheet of paper and draw its outer boundary.
2. Remove the bangle.
3. Take a point, say A, on the boundary drawn and mark it.
4. Put one end of the thread at 'A' and fix it firmly with your thumb of the left hand.
5. Now place a small portion of the thread along the boundary keeping it taut with fingers of other hand to reach at point B as shown in [Fig.6.8.2].
6. Now hold the thread at point 'B' with one hand.
7. Using the other hand, taut a little more portion of the thread along the boundary.
8. Go on repeating this process till you reach back to the point 'A'.

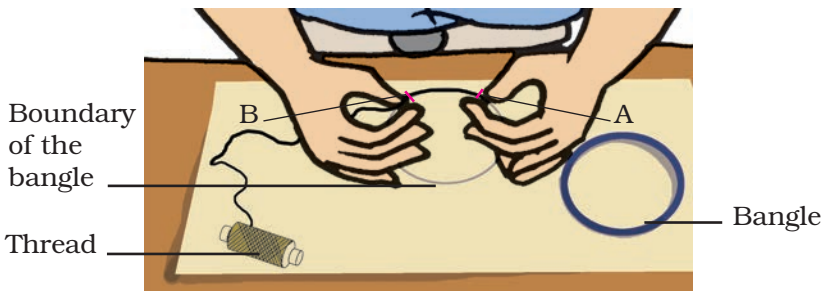

Fig.6.8.2 Measurement of the perimeter of a bangle

9. Now make a mark on the thread where it touches again at 'A'.
10. Measure the length of the thread from one end to the marked point.
11. Repeat the steps from 4 - 10 at least one more time.
12. How is this measured length of the thread related to the perimeter of the bangle? This length gives the perimeter of the bangle.

What have you learnt?

We can measure the length of the curved objects by using a thread.

Extension

1. *How can we measure the diameter of a circular object without knowing its centre?
(Hint: The diameter of a circle is the largest distance between any two points on the boundary of the circle.)*
2. *Use this method to find out the perimeter of rectangular and triangular objects.*

ACTIVITY 6.8.3

How can we recognise the rectilinear motion of an object?

What is required?

A glass marble, poster colour/ink, a long sheet of white paper and a measuring tape.

How will you proceed?

1. Spread the white sheet of paper on a levelled surface.
2. Dip the glass marble in ink or poster colour (thick solution).
3. Roll the coloured marble on the white sheet of paper and observe the path followed by the marble from the impressions of the tracing on the paper sheet.
4. Do we observe the path of the marble straight throughout?
5. Could you identify the motion of the marble in this case? Is it rectilinear?

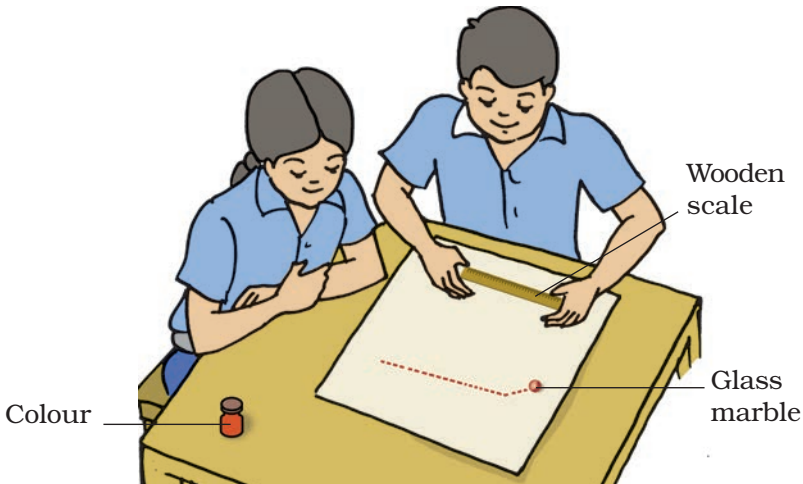

Fig.6.8.3 Motion of an object along a straight path

6. Measure the distance travelled by the marble while it is in rectilinear motion.

What have you learnt?

When an object moves along a straight path its motion is called rectilinear.

Extension

Perform the above activity using a ping-pong ball and a steel ball-bearing and observe in which case the motion is rectilinear for a longer time.

Notes

6.9 LIGHT, SHADOWS AND REFLECTIONS

ACTIVITY 6.9.1

Do all substances allow light to pass through them?

What is required?

Different objects like plastic scale, tracing paper, wooden scale, glass sheet, glass beaker, cardboard, white sheet of paper and wash bottle.

How will you proceed?

1. Look at an object, say a pencil, through the plastic scale, tracing paper, wooden scale, glass sheet, glass beaker, cardboard, white sheet of paper and wash bottle separately [Fig 6.9.1].

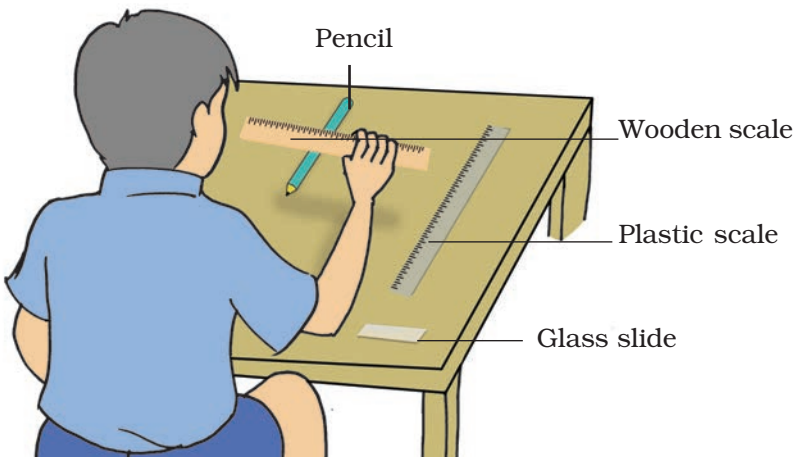

Fig.6.9.1 Seeing object using transparent, translucent and opaque object

2. Group the objects through which the pencil
(a) is seen clearly
(b) can be seen faintly (dimly).
(c) is not seen at all.
3. Do you know the materials with which these objects are made of?
4. On the basis of above observations classify the materials as transparent, translucent and opaque.

What have you learnt?

Some substances allow light to pass through them completely, some partially and some do not allow the light to pass through them at all. These are known as transparent, translucent and opaque substances, respectively.

Extension

List some more examples of transparent, translucent and opaque materials which you find in your everyday life.

ACTIVITY 6.9.2

How can you make an opaque paper translucent?

What is required?

sheet of opaque white paper, oil and an object (burning candle).

How will you proceed?

1. Take a sheet of white paper.
2. Look at an object, say a burning candle through it. Can you see the candle flame [Fig.6.9.2 (a)]?
3. Now smear few drops of oil at the middle portion of the sheet of paper.
4. Look at the burning candle through this portion of the paper again.
5. What do you observe? Is the candle flame visible now [Fig.6.9.2 (b)]?
6. What changes did you notice to the portion of the white paper when you smeared oil on it?

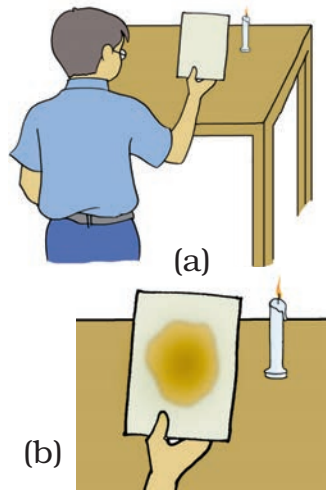

Fig.6.9.2 (a) Seeing object through a white sheet and (b) through a translucent paper prepared by smearing oil on it

The portion of the paper becomes translucent and therefore you are able to see the object (candle flame) faintly through it.

What have you learnt?

A translucent paper can be prepared by smearing oil on a thin sheet of opaque white paper.

ACTIVITY 6.9.3

How are shadows formed?

What is required?

Generator, a bob, torch bulb, transparent glass plate, a ground glass plate and a metallic scale.

How will you proceed?

1. Place a torch bulb near a wall (or a screen) and connect it with the generator.
2. Place an opaque object such as a bob or a metallic scale in between the bulb and the wall.
3. Rotate the handle of the generator to give electrical power to the bulb so that the bulb is lighted.
4. What do you observe on the wall [Fig.6.9.3]?
5. Is there a shadow on the wall?
6. Now move the opaque objects away from the bulb.



Fig.6.9.3 *Opaque objects cast shadows on a screen when light falls on them*

7. What happens to the nature of the shadow formed?
8. Now replace the bob or the metallic scale by a transparent glass plate.
9. Do you still observe a clear shadow on the wall?
10. Replace the transparent glass plate by a ground glass plate (translucent).
11. Could you see a clear shadow of the ground glass plate on the wall?
12. In which of the above three cases is the shadow most clearly formed?
13. On the basis of your observations, conclude the kinds of obstacles (transparent/translucent/opaque) which can form a clear shadow.

What have you learnt?

Opaque objects cast shadows on a screen more clearly when light falls on them.

Notes

Activity 6.9.4

How does light travel?

What is required?

A long rubber tube,
candle and a match box.

How will you proceed?

1. Light the candle and keep it at about 2 m distance from you.
2. Keeping the tube straight in the direction of the candle flame, observe the flame from the other end of the tube [Fig 6.9.4 (a)].
3. Is the flame visible?
4. Then bend the tube in different directions and observe the flame again through the tube [Fig 6.9.4 (b)].
5. Is the flame visible now? Why is the flame not visible when the tube is bent?

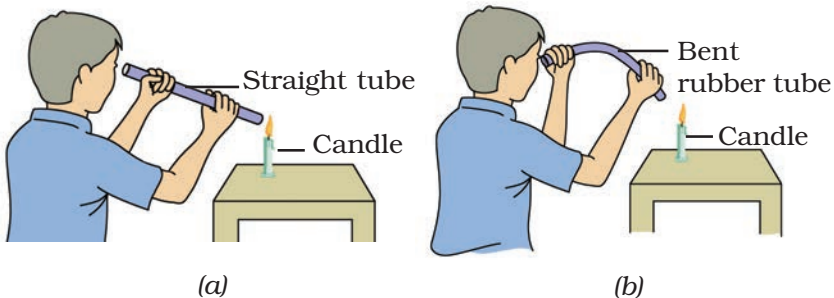

Fig.6.9.4 Using straight and bent tubes to see objects

What have you learnt?

Light travels in a straight line.

ACTIVITY 6.9.5

How an image is formed in a pinhole camera?

What is required?

Two thick black paper sheets of size 15 cm X 20 cm, tracing paper, glue, cello tape, pair of scissors and a needle.

How will you proceed?

1. Make two cylindrical tubes using the thick black paper sheets such that the one just slides into the other.
2. Fix the tracing paper to one end of the inner sliding tube.
3. Cover one end of the outer tube with a circular piece of thick black paper sheet by using glue.
4. Make a pinhole at the centre of the circular piece of black paper sheet attached at the end of the outer tube.
5. Slide the inner tube into the outer tube keeping the tracing paper towards you. Now, the pinhole camera is ready [Fig 6.9.5].
6. Keep the pinhole of the camera towards the well illuminated distant object like a tree or a building.
7. Observe how the distant object looks like on the tracing paper attached at the end of the inner tube.
8. Slide the inner tube inside the outer tube and find out the position when the image of the distant object is seen most clearly on the tracing paper.
9. Move the pinhole camera up, down and sideways while observing the image of the distant object.

10. Do you still see the image of the distant object on the tracing paper of the pinhole camera in all the positions distinctly? If not, discuss why?
11. What do you conclude from the above observations?
12. Draw diagram to show how the pinhole camera works and state how light travels.

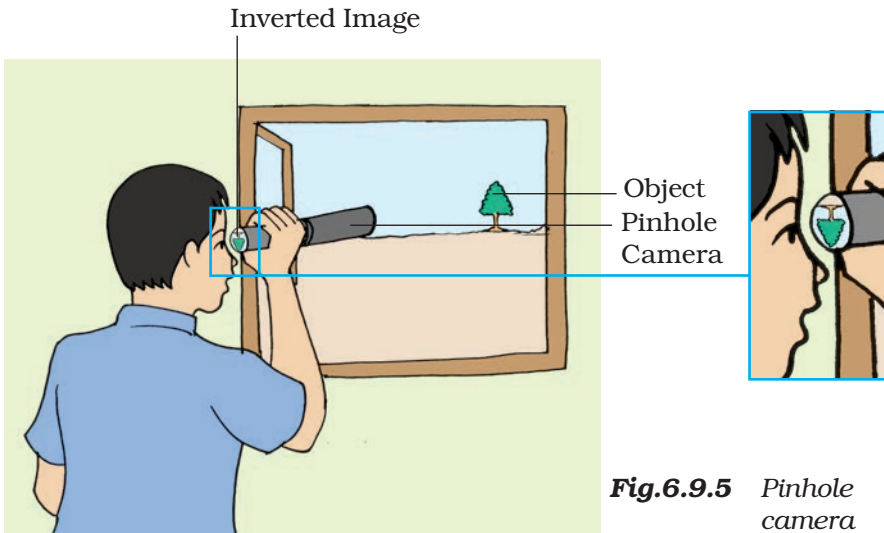

What have you learnt?

Light travels in a straight line.

ACTIVITY 6.9.6

What happens to light falling on a plane mirror?

What is required?

Generator, ray streak apparatus, plane mirror and a white sheet of paper.

How will you proceed?

1. Connect the bulb of the ray streak apparatus with the generator.
2. Place the ray streak apparatus on a white sheet of paper.
3. Rotate the handle of the generator.
4. What do you observe on the paper when the bulb starts glowing?
5. Is the beam of light parallel?
6. Place a plane mirror in its path [Fig 6.9.6].
7. What happens to the beam of light falling on the mirror?

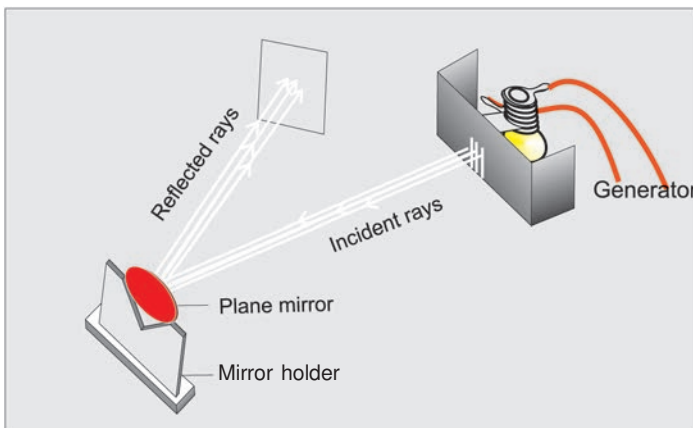

Fig.6.9.6 A plane mirror reflects a beam of light

What have you learnt?

- 1. Light falling on a plane mirror is reflected.*
- 2. A parallel beam of light falling on the plane mirror is reflected as a parallel beam.*

Extension

Turn the plane mirror first towards left and then towards right and observe the reflected beam.

- 1. What do you conclude from the above observations?*
- 2. Do you find any change in the shape of the reflected beam?*
- 3. Do you find any change in the direction of the reflected beam?*

ACTIVITY 6.9.7

How does an image of a person appear in a plane mirror?

What is required?

Plane mirror.

How will you proceed?

1. Take a plane mirror.
2. Stand in front of it.
3. What do you observe in the plane mirror?
4. Raise your left arm and observe your image.
5. Which arm of the image appears to be raised left or right? Repeat this with your right arm and conclude [Fig. 6.9.7].



Fig.6.9.7 Image formation using plane mirror

What have you learnt?

1. A plane mirror forms an image of an object placed in front of it.
2. In a mirror the left appears right and the right appears left such that only the sides are interchanged.

ACTIVITY 6.9.8

What is the nature of the image formed by a plane mirror?

What is required?

Plane mirror, candle, match box and a mirror stand.

How will you proceed?

1. Place a plane mirror vertically on a table using a stand.
2. Now bring a lighted candle in front of the mirror. [Fig. 6.9.8].
3. Observe the image of the flame of the candle in the mirror.
4. Is the image formed in the mirror
 - (a) erect or inverted?
 - (b) enlarged or diminished?
 - (c) of the same size as the object?
5. Now move the candle forward and backward and observe whether the image of the candle flame
 - (a) changes in size.
 - (b) remains erect or becomes inverted as the flame moves towards or away from the mirror.

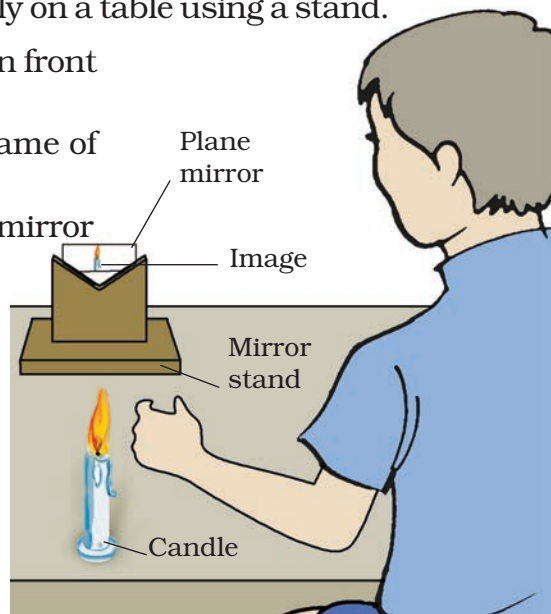

Fig.6.9.8 Image formed by using a plane mirror

What have you learnt?

Image formed in a plane mirror is erect and is of the same size as the object.

ACTIVITY 6.9.9

How can we see objects which cannot be seen directly?

*What is required?
Periscope (from the kit).*

How will you proceed?

1. Take periscope from the kit.
2. Keep one end of the periscope towards an object and see through the other end [Fig 6.9.9] by adjusting the angle of the mirror.
3. Is the object visible? If yes, why?
4. Now use the periscope to see objects placed on the table while you are sitting underneath and can not see them directly.

5. Explain why you can see the objects placed on the table while you are sitting underneath.

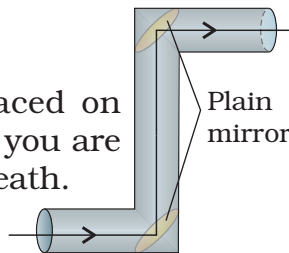

Fig.6.9.9 Periscope

What have you learnt?

Light can undergo multiple reflections.

Extension

Make your own periscope by using cardboard or two large tooth paste packings by fixing mirror strips.

6.10 ELECTRICITY AND CIRCUITS

ACTIVITY 6.10.1

How can we make a simple electric circuit?

What is required?

Dry cell, cell holder, switch with plug pins, connecting wires having banana plug pins, torch bulb, bulb holder and circuit board.

How will you proceed?

1. Take a circuit board and connect the cell holder and torch holder in it.
2. Place the torch bulb and cell in the respective holder.
3. Also place the cell and switch in the sockets of the circuit board.
4. Now connect the bulb to the cell through the switch as shown in [Fig.6.10.1]. This is a simple circuit having a dry cell, a switch and a torch bulb.

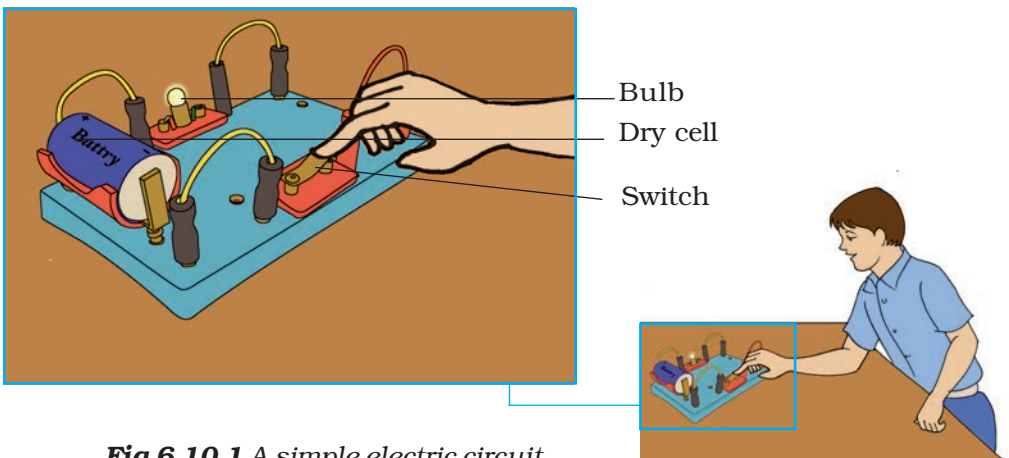

Fig.6.10.1 A simple electric circuit

5. What happens to the bulb when circuit is switched ON?
6. What do you observe when circuit is switched OFF?

What have you learnt?

A simple electric circuit consists of a cell, a bulb, a switch and connecting wires. When the switch is on, the circuit is closed and the bulb glows.

Extension

1. *Interchange the position of the bulb and the switch on the circuit board. Observe whether the bulb glows or not.*
2. *Interchange the +ve and -ve terminals of the cell on the circuit board and observe its effect on the intensity of the glow of the bulb.*
3. *Note down your observations and conclude.*

ACTIVITY 6.10.2

How can we identify conductors and insulators?

What is required?

Kit items made up of different substances such as plastic scale, glass rod, eraser, iron rod, aluminium rod, piece of wood, rubber band, circuit board, banana pin plug, torch bulb and a dry cell, etc.

How will you proceed?

1. Make a circuit on the circuit board with bulb, dry cell and switch as shown in [Fig.6.10.2].
2. Insert the objects (i.e. plastic scale, glass rod, iron rods, etc.) one by one in the gap A B. Observe whether the bulb glows or not.

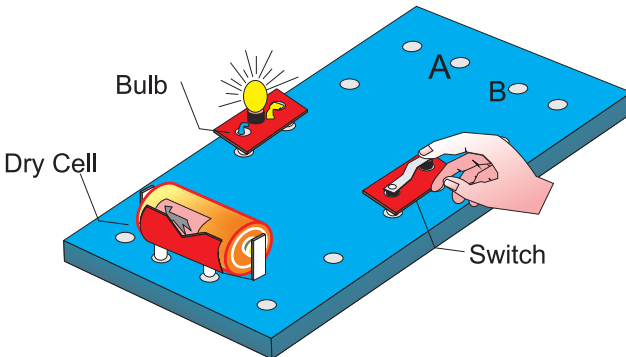

Fig. 6.10.2 Circuit board connected with a bulb, a switch and a cell

3. Note down your observations and conclusions in the table given below.

Sl.No.	Name of the object	Material	Observation (whether the bulb glows or not)	Conclusion (Insulator / Conductor)
1.	Eraser	Rubber		
2.	Iron rod	Iron		
3.				
4.				

What have you learnt?

Bulb glows when current passes through it. Some materials allow electric current to pass through them and some do not. **Conductors** allow the electric current to pass through them and that is the reason why the bulb glows. Reverse is the case with **insulators**.

Extension

Repeat the above activity with a graphite rod and pencil lead. Does the bulb glow in each case? What do you infer from your observations?

ACTIVITY 6.10.3

How can we make an electric switch?

What is required?

Wooden block or thermocol sheet, drawing pins and safety pin or paper clip.

How will you proceed?

1. Insert a drawing pin into the ring of the safety pin.
2. Fix it on the thermocol sheet or on the wooden block.
3. Make sure that the safety pin can be rotated freely.
4. Now fix the other drawing pin on the thermocol sheet in such a way that the free end of the safety pin can touch it. The safety pin fixed in this way would serve as an electric switch.
5. Now take the circuit board having a cell and a torch bulb fixed on it.
6. With the help of connecting wire connect your electric switch in the circuit [Fig. 6.10.3].
7. Observe the bulb when safety pin (a) touches the drawing pin; (b) does not touch the drawing pin?
8. When does the bulb glow?

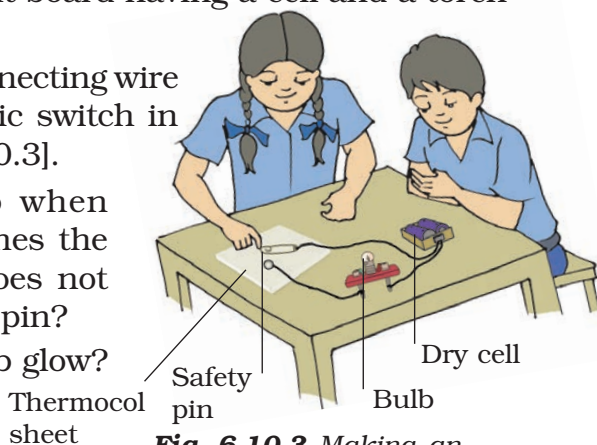

Fig. 6.10.3 Making an electric switch

What have you learnt?

An electric switch is a make and break arrangement.

When contact is made we say switch is ON, the circuit gets closed and the bulb glows.

ACTIVITY 6.10.4

*Does tap water
conduct electricity?*

What is required?

Two dry cells, cell holder, one light emitting diode(LED), plug key, a plastic cup, tap water, distilled water, connecting wires and crocodile clip .

How will you proceed?

1. Fill tap water in a plastic cup.
2. Dip two crocodile clips connected with wires in water without touching each other.
3. Connect one of the wires joined with these clips with a LED and the other wire to the cell through a switch and complete the circuit as shown in the figure [Fig 6.10.4].
4. Now switch ON the circuit and check whether LED glows. If the LED does not glow, then interchange

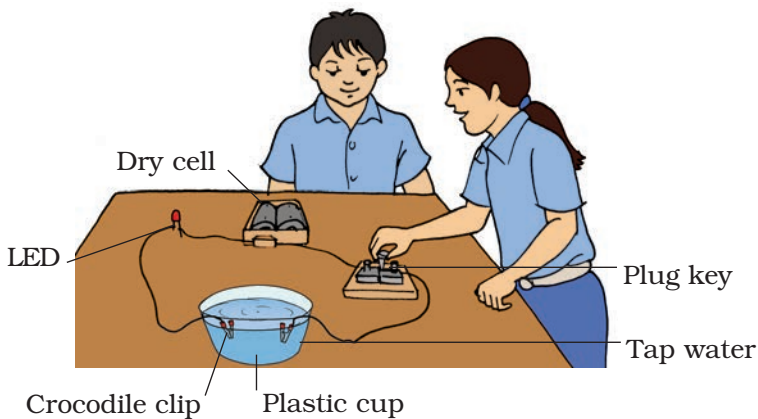

Fig 6.10.4 Circuit arrangement using LED to test whether tap water conducts electricity or not

the terminals of the LED and check again [Note: LED glows only when current flows through it in a particular direction]. Does the LED glow now? What does this indicate?

5. Does the tap water conduct electricity or not? Give your conclusion.

What have you learnt?

Tap water conducts electricity.

Extension

Repeat the above activity with distilled water and observe. What do you infer? Add some salt to this water and repeat the activity. What inference can you draw now?

Notes

6.11 FUN WITH MAGNETS

ACTIVITY 6.11.1

How can we test whether a given object is a magnet or not?

What is required?

Magnets of different shapes, a pencil, an iron nail, a glass rod, thread, iron filings, G-clamp allpins, a sheet of paper, shoe nails and a compass needle.

How will you proceed?

1. Place the objects (i.e. pencil, iron nail, glass rod, magnets, shoe nail, allpins; etc.), one by one on iron filings spread on a paper.
2. See if the iron filings stick on the different objects or not [Fig. 6.11.1].

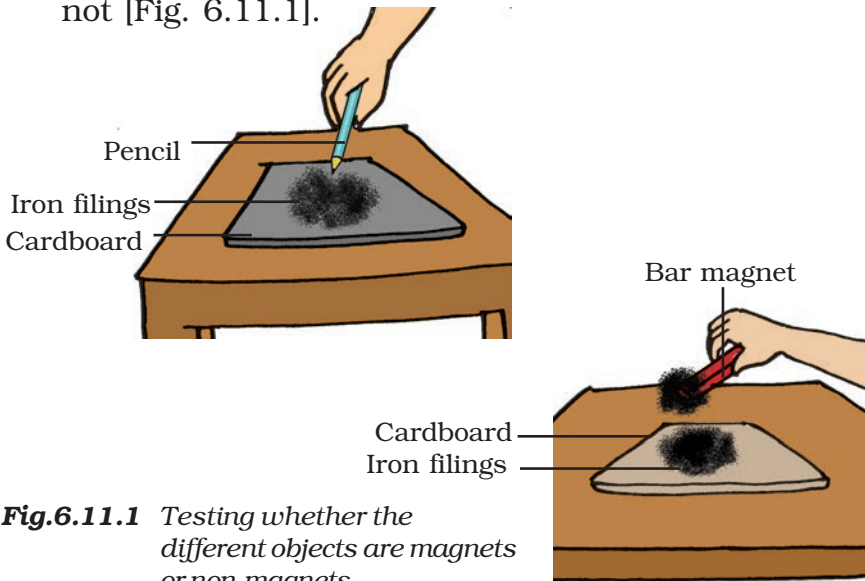
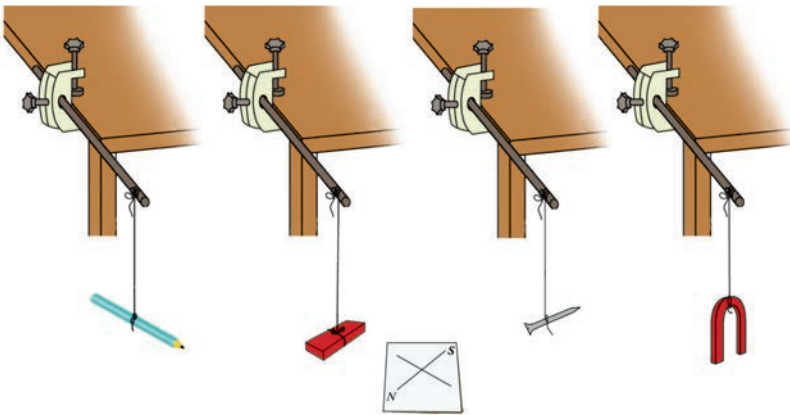

Fig.6.11.1 Testing whether the different objects are magnets or non-magnets

3. If the iron filings stick to the object, it is a magnet, otherwise not.
4. Classify the above objects in two groups:
(a) Magnets and (b) Non-magnets
5. Alternatively, suspend these objects one by one from a rigid support using a thread.
6. Observe in which direction the object rests.
7. Now disturb it from its position of rest and wait till it again comes to rest.
8. Note the direction in which it settles again.
9. Does the object settle in the same direction as previously ? If yes, it is a magnet. If not, it is not a non-magnet.



What have you learnt?

1. *Magnet attracts iron.*

2. *A freely suspended magnet always rests in a fixed direction.*

Extension

Bring each object one by one near to one end of a compass needle. Note whether the object attracts or repels that end of the needle. Now bring the other end of the object near to the same end of the compass needle and note the difference. What conclusion can you draw from this activity in the light of the fact that compass needle is also a small magnet and similar poles of two magnets repel each other?

Notes

ACTIVITY 6.11.2

In what different shapes magnets are usually made?

What is required?

Magnets of different shapes, a sheet of white paper and a pencil.

How will you proceed?

1. Take all the magnets given in the kit.
2. Arrange all the magnets on a table.
3. Observe the shapes of these magnets. Do they look alike? If no, then arrange them in different groups according to their shape [Fig. 6.11.2].
4. From your observation, how many different shapes of magnets do you have now on the table?
5. Observe the shape of magnets in each group.



Fig 6.11.2 Different types of magnets

6. Draw a rough diagram of each of these shapes on a sheet of paper.
7. Suggest a name for the shape of magnets in each group.
8. Record your observations in the following table.

Group	Shape of the magnets as they appear	Suggested name of the magnet according to its shape
1.		
2.		
3.		
4.		
5.		

What have you learnt?

Magnets can have different shapes.

Extension

Observe different devices/ toys in your every day life. Try to find out if there is any magnet used in them. Make a list of devices/toys where magnets are used. Also try to draw the shapes of these magnets.

ACTIVITY 6.11.3

Do all materials experience mutual attraction with a magnet?

What is required?

A strong magnet, objects made of different materials such as wood, plastic, iron, aluminum, glass, rubber and nickel, etc.

How will you proceed?

1. Place the given objects made of different materials on a table.
2. Now bring a strong magnet one by one near each of the object. What do you observe?
3. Do you feel any attraction between them in each case?
4. Do you find that the magnet and the objects tend to move towards or away from each other?
5. Do you find that there is no force between the magnet and some of the objects at all?

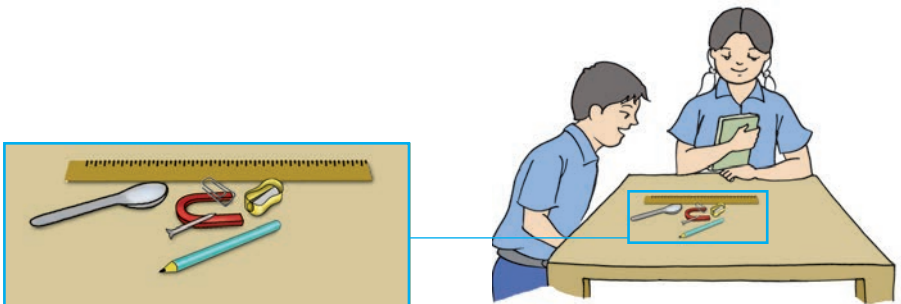

Fig.6.11.3 *Mutual attraction of a magnet using different materials*

Record your observations in a tabular form.
A sample table is given below for reference.

<i>Material of the object</i>	<i>Observation (attraction/repulsion/neutral)</i>	<i>Conclusion (magnetic substance/non-magnetic substance)</i>
Plastic Rubber Iron		

What have you learnt?

Materials attracted by a magnet are known as magnetic materials.

Notes

ACTIVITY 6.11.4

Does a magnet attract iron filings / nails equally at all its points?

What is required?

A bar magnet, U-shaped magnet, iron filings and a nails or allpins, etc.

Wrap the magnet in paper so that iron filings can be easily removed afterwards.

How will you proceed?

1. Spread iron filings on a sheet of paper placed over a table.
2. Put a bar magnet over the filings.
3. Take out the magnet. Observe the iron filings clinging to the magnet on its surface.
4. Do you find the iron filings uniformly stuck on the surfaces of the magnet? If not, where do you find the iron filings sticking in larger quantity?
5. Draw a diagram to represent your observation.
6. Compare your diagram with [Fig 6.11.4 (a)].

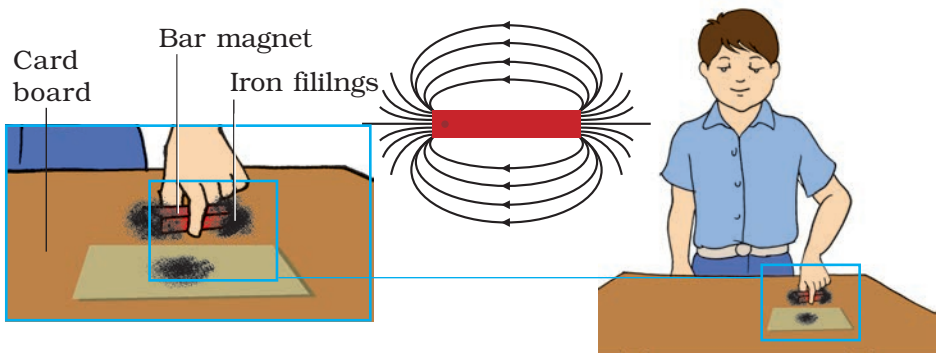

Fig.6.11.4 (a) Iron filings sticking to a bar magnet

7. Repeat this activity by using a U-shaped magnet. What is your observation now?
8. Again draw a diagram to show your observations using U-shaped magnet.
9. Now, bring few iron nails near different points of one end of the bar magnet so that they stick one behind the other as shown in [Fig. 6.11.4 (b)].
10. How many nails can you stick at different points on the bar magnet like that ?
11. Can you stick the same number of nails at every point of the magnet? Observe and give your conclusion.

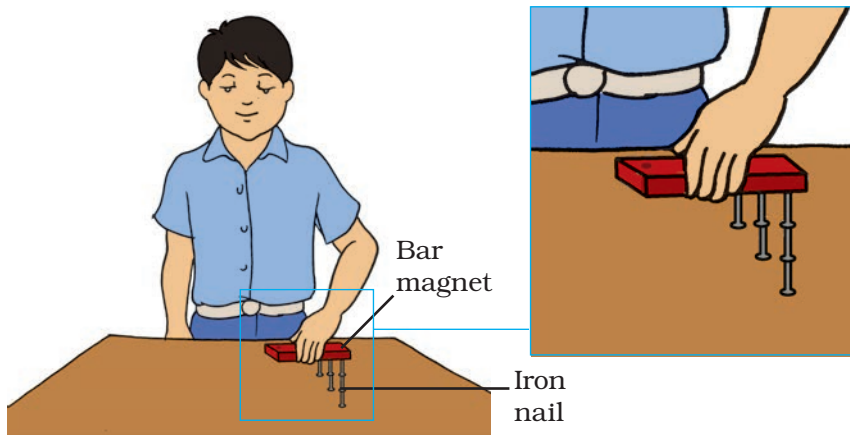

Fig.6.11.4(b) More nails stick to the magnet near its end

What have you learnt?

The amount of iron filings clinging is maximum at the two ends of a magnet.

ACTIVITY 6.11.5

How do we name the poles of a magnet?

What is required?

Compass needle, bar magnet, U-shaped magnet, a thread, a piece of chalk and G-clamp.

How will you proceed?

1. Draw a straight line on a table or floor using a chalk along north-south direction.
2. Place a compass needle over this line.
3. Observe the direction along which the needle rests.
4. Slowly rotate the compass keeping the centre of its needle on the line.
5. Observe the direction of the needle in different positions.
6. Does the needle of the compass change its alignment?
7. Can you make it align in a different direction?
8. Which end of the compass needle is pointing towards north?

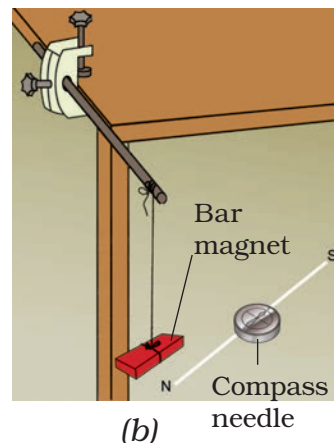
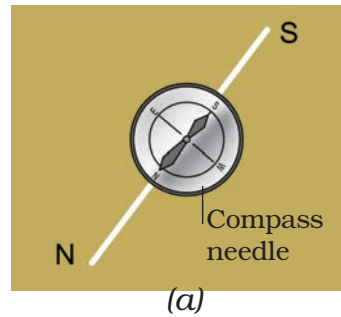

Fig.6.11.5 Finding the poles of a magnet using compass needle

- 9 Which end of the compass needle is pointing towards south?
10. Does the rotation of the compass change the direction of the needle as shown by these ends?
11. Now suspend a bar magnet freely from a stand using a thread.
12. Observe the direction in which the magnet rests.
13. Which end of the magnet points towards north?
14. Which end points towards south?
15. Mark 'N' at the end of the magnet pointing towards north. This is the 'North Pole' of the magnet.
16. Write 'S' at the end of the magnet pointing towards south. This is the 'South Pole' of the magnet.

What have you learnt?

The end of a freely suspended magnet pointing towards north is north pole and pointing towards south is south pole.

Extension

Repeat the above activity using a U-shaped magnet.

ACTIVITY 6.11.6

Can we make a magnet by ourselves?

What is required?

Bar magnet, iron nail, sewing needle and iron strip.

How will you proceed?

1. Take an iron nail and dip it in iron filings.
2. Check whether it is already a magnet or not .
3. Make sure that the nail chosen is not already a magnet.
4. Now place the nail on a flat surface.
5. Rub the nail with a bar magnet by touching its one pole along its length [Fig.6.11.6].
6. Rub the nail for some time.
7. Now test whether the nail has become a magnet or not.
8. You can test this by dipping the nail in iron filings.
9. What is your observation?
10. Does the nail become a magnet now?

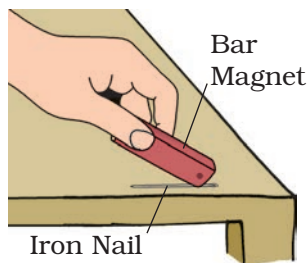

Fig 6.11.6 Rubbing a magnet over iron nail

What have you learnt?

An iron nail can be magnetised by rubbing a magnet on its surface.

Extension

Repeat the above activity to magnetise other iron objects like an iron strip or a sewing needle.

ACTIVITY 6.11.7

How can we make a simple compass needle?

What is required?

Bar magnet, sewing needle, thermocol disc of about 4 cm diameter and 1 cm thickness, small plastic tub, water and adhesive tape.

How will you proceed?

1. Magnetise the needle by rubbing it with a pole of a strong bar magnet (as suggested in the previous activity).
2. Place the needle at the centre of the thermocol disc and fix it with adhesive tape.
3. Place it gently over water taken in a tub such that it floats [Fig 6.11.7].
4. Observe the direction along which the needle rests. Is it pointing towards north-south direction?
5. Now your compass is ready.

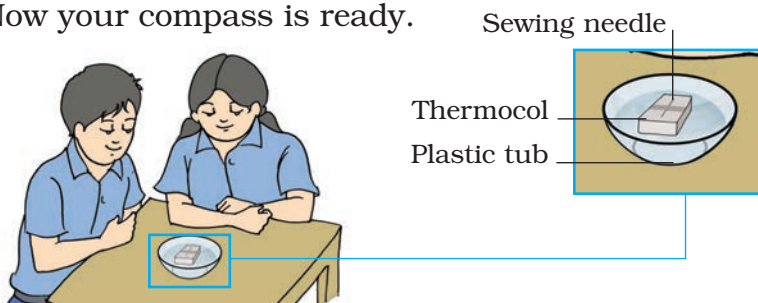

Fig.6.11.7 Making a simple compass needle

What have you learnt?

A needle can be magnetised and can be used as a compass needle.

ACTIVITY 6.11.8

Does the pole of a magnet always attract the pole of the other magnet?

What is required?

Two bar magnets, two cylindrical magnets, thread and compass needle .

How will you proceed?

1. Take two bar magnets.
2. Hold one magnet in each hand.
3. Bring the north-pole of one of these magnets near the north pole of the other magnet.
4. Observe what happens.
5. Now bring the south-pole of one of these magnets near the south-pole of the other.
6. What happens now?
7. What do the magnetic poles experience?
8. How do they behave? Does the similar pole of two magnets attract or repel each other?
9. Now, bring the north-pole of one of these magnets near the south pole of the other.
10. Note the change in the type of force experienced by the two magnet. Do you observe the force of attraction or repulsion between them?
11. Tabulate your observations.

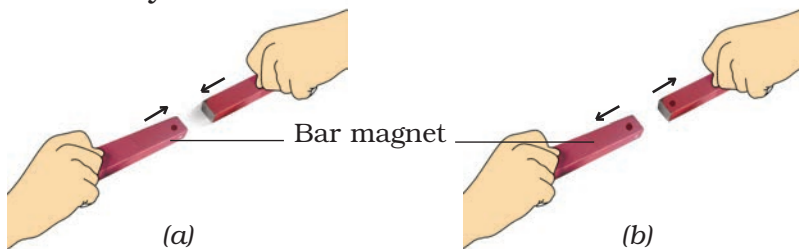

Fig. 6.11.8 (a) Unlike poles attract each other
(b) Like poles repel each other

What have you learnt?

Like poles repel and unlike poles attract each other.

Extension

Repeat the above activity using the cylindrical magnets. What do you observe? Is it different from your observations with respect to the bar magnets?

Notes

ACTIVITY 6.11.9

How can we compare the strength of two magnets using a compass needle?

What is required?

Two bar magnets and a compass needle.

How will you proceed?

1. Place a compass needle on a table.
2. Mark its boundary.
3. Notice that the compass needle points in north-south direction.
4. Now place the north pole of a bar magnet at a certain distance from the compass needle.
5. Note the extent of deflection on the compass needle.
6. Remove the bar magnet away from the compass needle.
7. Bring another bar magnet towards the compass needle.
8. Place its north pole exactly in the same position and at the same distance as taken in step No. 4 from the compass needle.
9. Again note the deflection on the compass needle.
10. Which magnet causes greater deflection on the compass needle?

What have you learnt?

Magnet causing more deflection on the compass needle is having more strength.

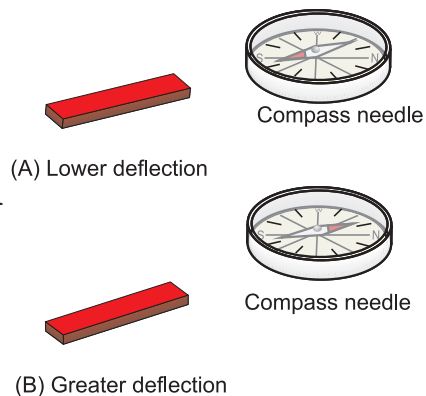

Fig. 6.11.8 Finding the strength of magnet using compass needle

ACTIVITY 6.11.10

Can a magnet lose its magnetic properties when heated?

What is required?

A bar magnet, forceps, kerosene burner, iron filings, compass needle and a sewing needle.

How will you proceed?

1. Take a sewing needle.
2. Rub it with a pole of a bar magnet for some time.
3. The needle becomes a magnet now.
4. Verify this with the help of a compass needle.
5. Also, verify this by dipping the needle in iron filings.
6. Make a rough estimate of the amount of iron filings that cling to the needle.
7. Remove all the iron filings from the needle.
8. Hold the needle over a flame with the help of forceps. Heat it for about 8 - 10 minutes.

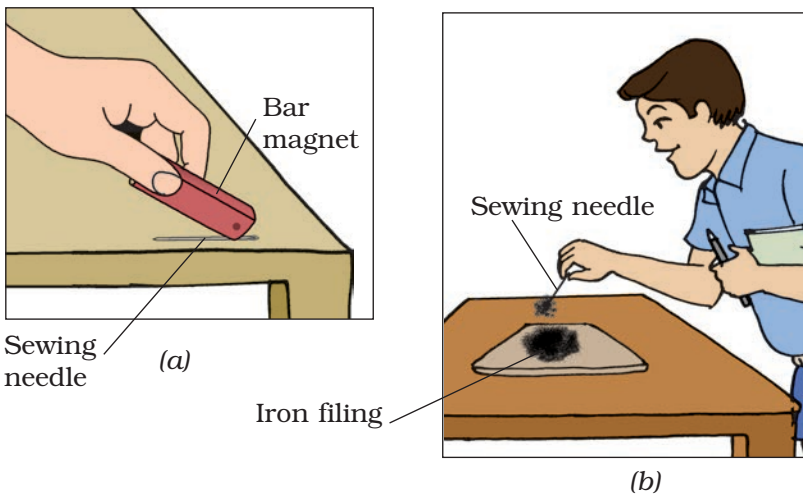

Fig.6.11.10 (i) Rubbing magnet over sewing needle

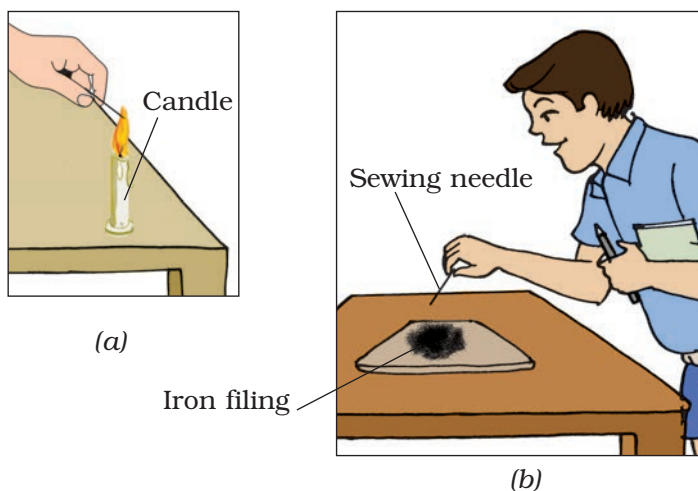

Fig.6.11.10 (ii) Magnet loses its strength on heating

9. Allow the needle to cool.
10. Now dip it again in iron filings.
11. Make an estimate of the amount of iron filings that cling to it now.
12. What is your observation?
13. What conclusion can you draw from this?
14. Can you test the strength of the needle-magnet using a compass needle?

What have you learnt?

Magnet loses its magnetic property on heating.

Extension

Check whether a needle magnet also loses its magnetic property by hammering or not.

6.12 WATER

ACTIVITY 6.12.1

What makes evaporation faster or slower?

What is required?

Two 10cm watch glass, one graduated syringe, some water.

How will you proceed?

1. Take two clean watch glasses and label them as A and B.
2. Keep A under direct sunlight and B in the open but under the shade.
3. Put 1 mL of water in both the watch glasses with the help of a syringe.
4. Occasionally observe both of them.

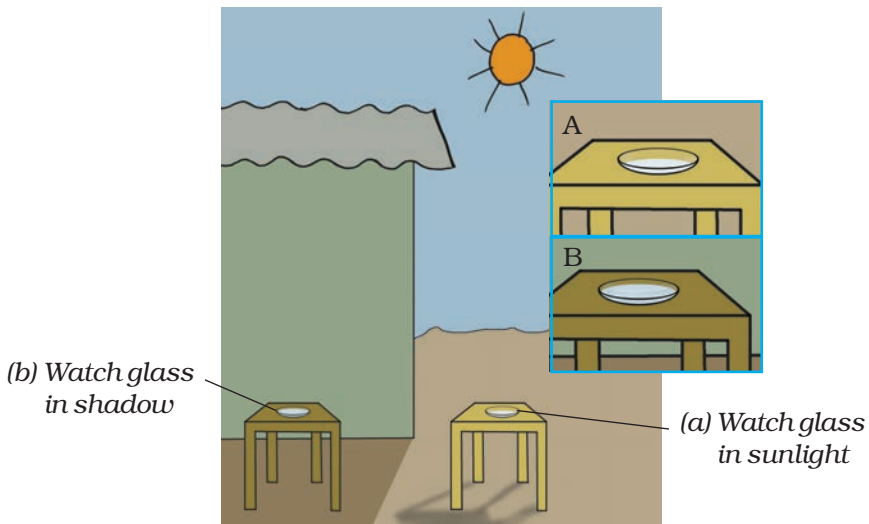

Fig.6.12.1 Evaporation in sunlight is faster than in shadow

5. Did you find any difference in the amount of water kept in them?
6. From which plate, did the water disappear faster?
7. Now touch both the watch glasses.
8. Which one was warmer? Can you think of the reasons?
9. Also, did you notice any mark or residue left in the watch glass after complete evaporation? What is this due to? Did water contain some dissolved materials?

What have you learnt?

1. *Evaporation is the process of conversion of a liquid (water) into its vapour (water vapour). It depends on various environmental factors.*
2. *Water kept in the watch glass A, which was kept under direct sunlight disappears faster, as compared to that in watch glass B kept under shade. Watch glass A becomes warmer than watch glass B.*
3. *The process of evaporation becomes faster at higher temperatures. In the above activity, water kept in watch glass A received direct and strong heat from the sun. This heat helped in water getting quickly evaporated. On the other hand, water in watch glass B kept in the shade could get heat only from the warm air. Thus, though water evaporated from this watch glass also, but the process was much slower.*

Extension

- 1. Repeat the above activity by keeping watch glass A in a closed room under circulating fan and watch glass B in another closed room without fan. Observe carefully from which watch glass water disappears faster? Give reasons for your observations.*
- 2. Take petri dishes which differ in size. One may be of 5 cm diameter and another of 7 cm diameter. Take equal volumes of water (say 5 mL) in both. Keep both of them under direct sun light. Observe the disappearance of water. In which dish does water disappear faster?*

Related Facts

1. Wet clothes dry sooner under the direct heat of sun as compared to those kept under shade.
2. In a closed room, wet clothes dry faster under a fan as compared to those kept in a room in which there is no circulation of air.
3. Water evaporated faster if taken in a wider vessel.
4. Rivers or lakes sometimes dry up during summers.
5. Freshly mopped floors dry very quickly in summers than in winter and under a running fan than in a room with a switched OFF fan.

ACTIVITY 6.12.2

Is there any water in air?

What is required?

A glass tumbler,
beaker, ice cubes, a
piece of cloth.

Air contains water vapours which enter the air through the processes of **evaporation** and **transpiration**.

How will you proceed?

1. Take a beaker (clean its outer surface with a piece of cloth if necessary) and keep it on a flat surface.
2. Put three or four ice cubes in the beaker.
3. Observe the outer surface of the beaker. What do you notice?
4. You must have noticed that the water droplets appear on the outer surface of the glass.
5. Where has this water come from?

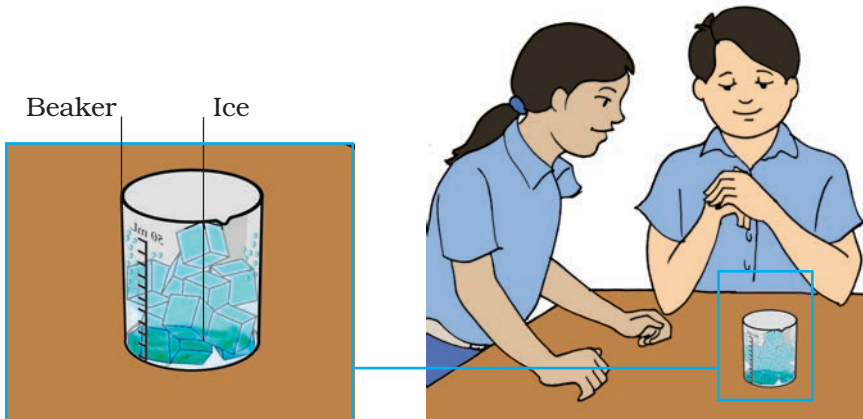

Fig.6.12.2 Process of evaporation and transpiration

What have you learnt?

- 1. The air contains water vapours.*
- 2. When the water vapours come in contact with cooler outer surface of the glass, it condenses on it in the form of water droplets.*

Related facts

1. As we go higher up in the atmosphere, the air becomes cooler. Because of this, the water vapours present in the air condense to form clouds.
2. When we take out any object from the refrigerator, water droplets are formed on its outer surface after some time.

Notes

6.13 AIR AROUND US

ACTIVITY 6.13.1

What can moving air do?

What is required?

A square piece of paper of size (22 cm × 22 cm), a pencil, a pair of scissors, a drawing pin, a small stick, crayon colours.

How will you proceed?

A. How to make the firki?

1. Take a square piece of paper of size (22 cm × 22 cm).
2. Fold the paper in half twice as shown in the Fig. (a) and (b) and you get a small square.
3. Fold the square into triangles as shown in the Fig. (c).
4. With the help of scissors, cut the middle line of the triangle upto three fourth so that the middle portion does not get separated as shown in Fig. (d).
5. Open the folds and put the numbers 1 - 8 on the triangles or put some colours on them as shown in Fig. (e).
6. Then fold the alternate number tips to the centre as shown in Fig. (f).
7. Fold 1, 3, 5, 7 to the centre and hold them together as shown in Fig. (g).
8. Fix these folded tips of paper to a stick by using a drawing pin and cover the pointed end of the pin by using plastic so that it does not hurt any one.

9. Go to an open place and hold the stick. Turn the firki in different directions and move it a little back and forth and observe what happens?

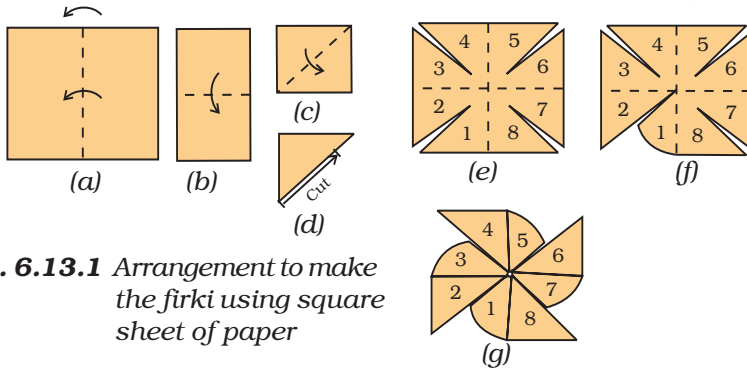

Fig. 6.13.1 Arrangement to make the firki using square sheet of paper

What have you learnt?

The moving air helps in rotating the firki.

Extension

You can try this activity by taking the firki in front of a table fan and also in a room without any or very small opening for the entry of air.

Related facts

1. Moving air rotates the blades of a wind mill.
2. Air helps in the movement of sailing yachts, gliders, parachutes, etc.
3. Very strong winds can cause cyclones, storms, etc. and which can have destructive effects.

ACTIVITY 6.13.2

Is air present everywhere? Is an empty bottle really empty?

What is required?

A bucket, a plastic bottle, water.

Air is present everywhere around us. It occupies all the space. It does not have any colour and is transparent.

How will you proceed?

1. Take a bucket and fill it about 3/4th with water.
2. Now take an empty plastic bottle and hold it upside down.
3. Try to fill the bottle by dipping it into the water taking care that it should be absolutely vertical.
4. What did you observe? Did water enter the bottle?
5. Now, tilt the bottle a little and try to fill the water in the bottle. What do you observe?
6. Record your observations and think of the reasons.

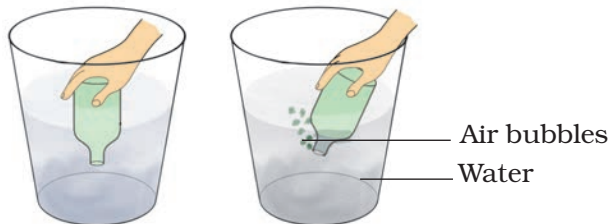

Fig.6.13.2 Presence of Air in empty bottle

What have you learnt?

Air is present everywhere and occupies all the available space. The bottle which looks empty is actually full of air. When the bottle was dipped in

an inverted and vertical position, water did not enter the bottle because air could not escape from it. But when the bottle was slightly tilted, air escaped from the bottle which was observed in the form of bubbles. Also, it created some space in the bottle which was occupied by the water and the bottle got filled with water.

Extension

1. Place a ping-pong ball on the surface of water in a bucket. Push the ball downwards with the help of the mouth of an inverted bottle. Observe carefully. Now slightly tilt the bottle and observe.
2. Take a bottle and fill it about half with water. Now, take a small plastic sheet and cut in the form of diver. Place this diver on the surface of water. Cover the mouth of bottle with a rubber sheet. Press the rubber sheet and observe. Give reasons for your observations.
3. Find out how a hovercraft moves.

Related facts

1. All the vehicles move on tyres which are filled with the compressed air.
2. Mountaineers or divers carry cylinders with them which are filled with oxygen.

ACTIVITY 6.13.3

What does air contain?

What is required?

A plastic or glass tub, two small candles of same size, two glass tumblers of different sizes but both larger than candles, some water, a match box.

Air is a mixture of gases. Of all these gases, burning can occur only in the presence of oxygen.

How will you proceed?

1. Take the glass or plastic tub. Fix two candles in it leaving a distance of approximately 6 cm in between them.
2. Now, fill the tub with some water.
3. Light the candles with the help of a matchstick.
4. Now take two glass tumblers of different sizes and invert them on each of the candles. (Take care that candle height should be such that it should not go beyond the middle of the glass) [Fig.6.13.3].
5. Observe the burning candles and the water levels in each glass carefully.
6. Which of the candles stopped burning earlier and why?
7. Did you notice any rise in water level in the glass tumblers? Was it same or different in the two glass tumblers?
8. You would have noticed that the flame of the candle goes out in the smaller glass tumbler earlier than that of the candle kept under bigger glass.

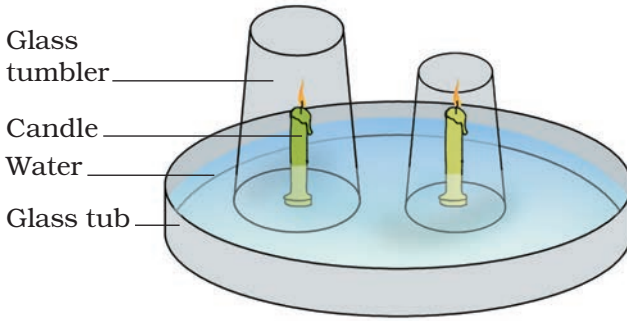

Fig. 6.13.3 Arrangement to show air is a mixture of gases

What have you learnt?

Air is a mixture of gases. It mainly consists of oxygen (21 per cent), nitrogen (78 per cent), water vapour, carbon dioxide and other gases. When the burning candle is covered by an inverted glass tumbler, it uses up one component of air, i.e. oxygen. When most of the oxygen is used up by the candle, it stops burning and the flame goes out. The consumption of oxygen turns to equal volume of carbon dioxide. The hot air around the flame becomes cool when flame goes out. This causes lowering of pressure, resulting into rising of water in the glass tumbler.

Extension

The above activity can be performed by putting a little red ink into the water. This will make the visualisation of rising water level more clear.

Note for Teachers

The teacher may avoid discussing the above activity based on the per cent of oxygen present in the air.

Related Facts

We inhale atmospheric air which contains oxygen. This oxygen reaches the cells and combines with the food (glucose). The oxygen 'burns' the food and releases energy.

UPPER PRIMARY SCIENCE KIT MANUAL

FOR CLASS VII

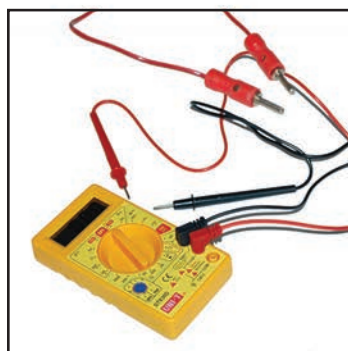

7.1 NUTRITION IN PLANTS

ACTIVITY 7.1.1

What are the conditions necessary for photosynthesis?

What is required?

Freshly plucked coleus leaves, beakers, test tubes, tripod, water, rectified spirit, kerosene burner, petri dish, iodine solution, dropper, black paper, U-clip to hold the paper and potassium hydroxide solution

How will you proceed?

To test a leaf for starch (Iodine test):

1. Dip the leaf in boiling water for a minute to rupture the cells.
2. Boil the leaf in methylated spirit over a water bath (beaker filled with water) till it becomes pale-white due to the removal of chlorophyll. The leaf now becomes hard and brittle.
3. Place it again in hot water to soften it.

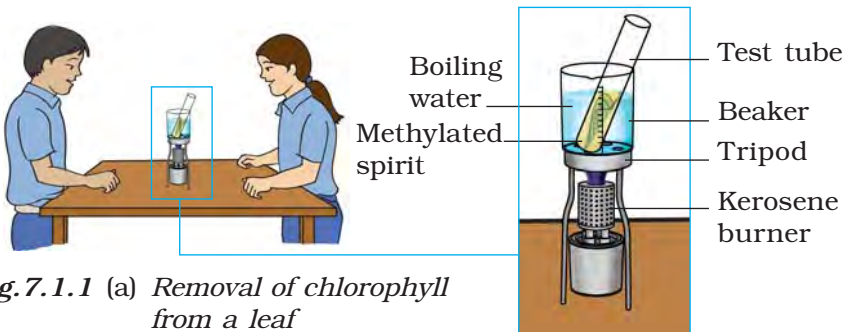

Fig. 7.1.1 (a) *Removal of chlorophyll from a leaf*



Before iodine test



After iodine test

Fig. 7.1.1(b)
Chlorophyll is necessary for photosynthesis



Before iodine test



After iodine test

Fig. 7.1.1 (c)
Only the parts of the leaf exposed to sunlight give the positive test with iodine test

4. Spread the leaf in a petridish and put 5 - 8 drops of iodine solution on it. Presence of starch will be indicated by a blue-black colour. A part of the leaf without starch will show brown coloration.

A. To show that chlorophyll is necessary for photosynthesis:

1. Take a plant with (coloured) leaves having some green and some coloured areas. Example: Coleus and Croton.

2. Destarch the leaves by keeping the plant in a dark room for a few days.

3. Place the plant in the sun for a few hours.

4. Afterwards, pluck one leaf.

5. Make its outline on paper and mark inside the outline the green and coloured areas.

6. Test the leaf for starch. Only the green parts of the leaf turn blue-black, showing the presence of starch.

B. To show that sunlight is necessary for photosynthesis.

1. Take a plant with destarched leaves.

2. Cover one of its leaves with black paper on which design is cut.

3. Take the plant in the Sun for few hours.

4. After a few hours, test the leaf which is covered by black paper for the presence of starch. It will be observed that only those parts of the leaf which were left uncovered by the paper, turn blue-black, showing the presence of starch.

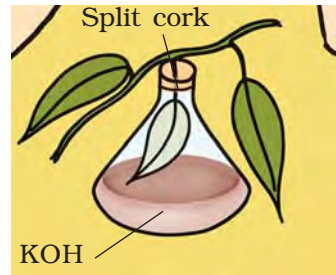

*Fig. 7.1.1 (d)
Carbon dioxide is
necessary for
photosynthesis*

C. To show that carbon dioxide is necessary for photosynthesis:

1. Take a branch of a plant with destarched leaves.
2. Insert one of its leaves (through a split cork) into a conical flask containing potassium hydroxide. Potassium hydroxide absorbs carbon dioxide.
3. Leave the plant in sunlight.
4. After a few hours, test this and any other leaf of this plant for starch by using the iodine test.

The leaf which was exposed to the atmospheric air becomes blue-black, and the one inside the flask containing potassium hydroxide does not become blue-black, showing that carbon dioxide is necessary for photosynthesis.

What have you learnt?

Plants manufacture their food (starch) with the help of water and carbon dioxide. This process (photosynthesis) occurs in the chlorophyll containing cells of the leaves and takes place in the presence of sunlight.

7.2 HEAT

ACTIVITY 7.2.1

How can we measure temperature using laboratory thermometer?

What is required?

Laboratory thermometer, beaker, tripod stand, kerosene burner, G-clamp stand and water.

How will you proceed?

1. Take water in a beaker.
2. Fix the thermometer in a G-clamp stand.
3. Look at the markings of thermometer, i.e, note the minimum and maximum temperature of the thermometer scale.
4. Dip the bulb of the thermometer in water kept in a beaker. Ensure that the bulb does not touch the wall of the beaker.
5. Note the reading of the thermometer when mercury thread becomes steady. Remember that you should read the thermometer keeping the level of mercury along the line of sight.
6. Now heat the water with the help of the kerosene burner.
7. Put the beaker with hot water on the table. Now dip the thermometer in water and observe the mercury thread [Fig. 7.2.1].
8. Observe the mercury thread for about 10 minutes. What do you find?
9. Do you find any change in the reading of the thermometer?

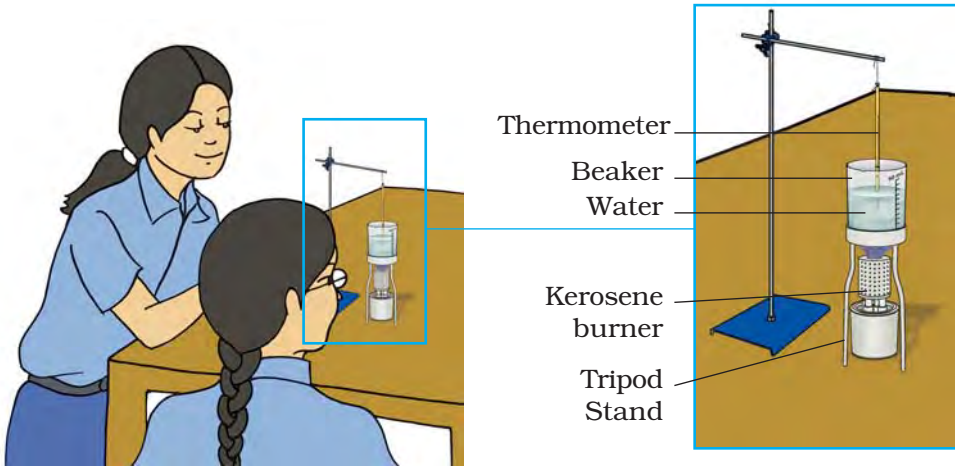

Fig. 7.2.1 Arrangement for measuring temperature of water using a laboratory thermometer

What have you learnt?

Temperature of an object can be measured with the help of a laboratory thermometer.

Extension

*Try to measure the body temperature using a laboratory thermometer.
Do you find any difficulty?*

ACTIVITY 7.2.2

How can we measure our body temperature in degree Celsius ?

What is required?
Clinical thermometer having both °Celsius and °Farenheit scales of temperature.

How will you proceed?

1. Wash the thermometer with clean water and then with antiseptic solution.
2. Note the reading of thermometer. It should be below 35°C .
3. If it is not below 35°C , then hold the thermometer firmly and shake it till the thread of the thermometer falls below 35°C .
4. Place the bulb of the thermometer under your tongue and keep it there for about one minute.
5. Now take out the thermometer from your mouth.
6. Note the reading of the thermometer in degree Celsius by keeping the level of mercury along the line of sight.
7. Repeat this activity with your two-three friends to find their body temperature.

Clinical thermometer

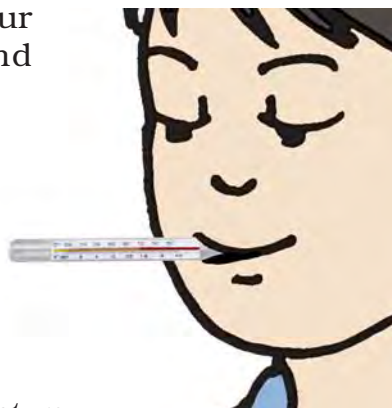

Fig. 7.2.2 Measuring body temperature using clinical thermometer

What have you learnt?

We can measure the body temperature by clinical thermometer.

Extension

- 1. Measure the body temperature of some of your friends in $^{\circ}\text{C}$ and then find the average body temperature. Compare this temperature with your body temperature.*
- 2. Also, measure your body temperature in $^{\circ}\text{F}$.*

Notes

ACTIVITY 7.2.3

How can we show that the rate of heat conducted by different substances is different?

What is required?

T-shape holder, two rods of same dimensions made of different materials (such as iron and aluminium), kerosene burner, match box, candle wax, clamp, iron rod, boss head, G-clamp.

How will you proceed?

1. Take two identical rods of same dimension, one of aluminium and the other of iron.
2. Fix them in T-shape holder. Fix the holder in the clamp.
3. Fix small pieces of candle wax on each rod at equal distances as shown in Fig.7.2.3.
4. Now heat the middle part of the T-shape holder.
5. What happens to the small pieces of wax fixed on the rods?

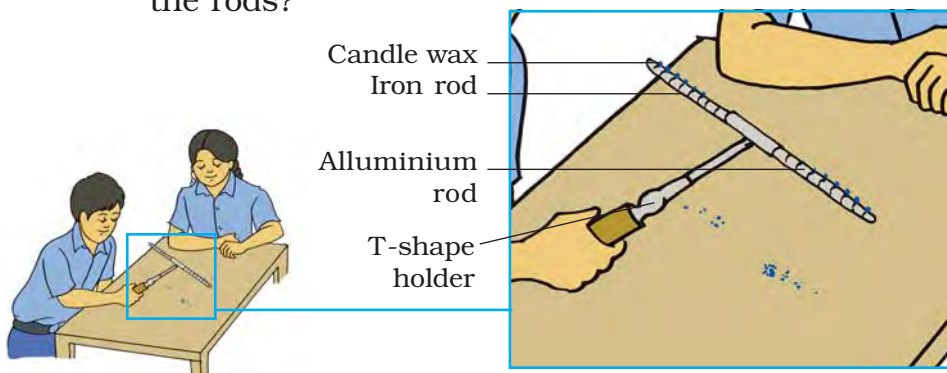

Fig. 7.2.3 Arrangement to show the conduction of heat in aluminium and iron rod fitted in a T-shape holder

6. Observe from which rod does the wax start falling first ?
7. How would you conclude your observations?

What have you learnt?

1. The rate at which heat is conducted by different substances is different.
2. Aluminium rod conducts heat more easily than an iron rod of the same dimensions.

Extension

1. Observe the cooking utensils. Which metals are these made of? Make a list of them.
2. Observe the handles of different cooking utensils. Name the materials used in making them.

ACTIVITY 7.2.4

Which of the two identical bodies (one dark-coloured and the other light-coloured) will absorb more amount of heat when kept under similar conditions?

How will you proceed?

1. Paste a black sheet of paper on one can and a white sheet of paper on another can. Ensure that there is no gap in between paper and the tin can.
2. Pour equal amount of water in both the cans.
3. In the beginning the temperature of water in both the cans must be same. To verify it, you can use laboratory thermometer.
4. Cover the cans from the top and leave both the cans in Sun for about two hours. Ensure that the two cans

What is required?

Two laboratory thermometers, black sheet of paper, white sheet of paper, two identical tin cans, cellotape and water.

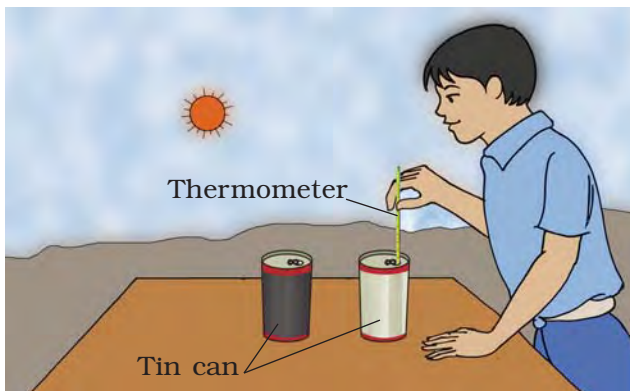

Fig. 7.2.4 Measuring temperature

must be covered by two pieces of small cardboard so that it will not obstruct in heating the cans.

5. Measure the temperature of water in both the cans.
6. Do you observe any difference in temperature of water in two cans?
7. What do you infer from this?

What have you learnt?

Dark coloured bodies are good absorbers of heat.

Extension

1. Take two identical cloths/papers, one black and the other white. Leave them in the sun for about 2 hours. Measure the temperature of the cloths/papers with the help of laboratory thermometer.

Do you find any difference in the temperature between the two?

2. Take two identical thermometers. Wrap the bulb of one thermometer with black cloth and the bulb of the other thermometer with white cloth. Leave both the thermometers in the sun for about 20 - 30 minutes.

Do you find any difference in the readings of two thermometers?

What conclusion can be drawn from the above activity?

ACTIVITY 7.2.5

How can we show heat transfer in liquids?

What is required?

A beaker (50 mL), potassium permanganate, kerosene burner, tripod stand, water and straw.

How will you proceed?

1. Take a beaker .
2. Fill it 2/3rd with water and place it on the tripod stand.
3. Place a crystal of potassium permanganate gently at the bottom of the beaker using a straw.
4. Now heat the water by keeping the kerosene burner just below the potassium permanganate crystal. Ensure that the flame of the burner is kept low so that heating is slow.

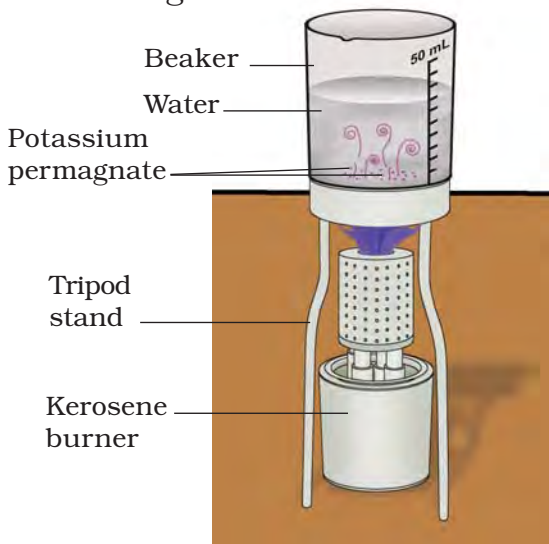

Fig.7.2.5 Transfer of heat in liquid

5. Note the changes taking place in the beaker carefully.
6. Do you observe any convection currents in the beaker?

What have you learnt?

In liquids heat is transferred by convection.

Extension

Perform this activity by using used tea leaves in place of potassium permanganate crystals. You may observe the movement of tea leaves when water is heated.

Notes

Activity 7.2.6

How can we show heat transfer in gases?

What is required?

A sheet of paper, a match box, a candle, thread, a pencil and a pair of scissors .

How will you proceed?

1. Cut a round sheet of paper of diameter about 20 cm.
2. Draw a spiral on it as shown in Fig.7.2.6.
3. Cut the paper along the marked line using a pair of scissors.
4. Suspend the paper from its central point vertically using a thread.
5. Now light a candle and bring it below the paper spiral. Ensure that the flame should be kept at a distance so that the paper will not burn.
6. Observe what happens?
7. Will the paper spiral start rotating?
8. Why does the paper spiral start rotating?

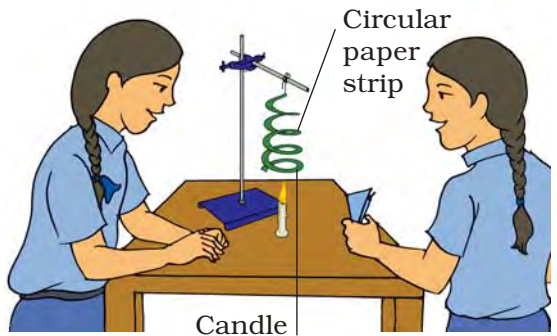

Fig. 7.2.6 Arrangement to show heat transfer in gases

What have you learnt?

Transfer of heat in gases takes place by convection.

The air near the candle become light on heating and starts rising. The rising air strikes the paper spiral which starts rotating.

7.3 ACIDS, BASES AND SALTS

ACTIVITY 7.3.1

Is your shampoo acidic or basic?

What is required?

shampoo, blue and red litmus papers, turmeric paper, extract of china rose flowers, test tube, dropper.

Substances can be acidic, basic or neutral in nature. Their nature can be identified using *indicators*. The substances which change their colour when added to acidic or basic substances are called *indicators*. Some common indicators are *litmus paper*, phenolphthalein, *turmeric* and *extract of china rose flower*.

How will you proceed?

1. Dilute one drop of shampoo with 10 drops of water.
2. Take red and blue litmus papers and turmeric paper.
3. Using a dropper, put one drop of shampoo solution on each of these indicator papers [Fig.7.3.1 (a)].
4. What do you observe? Record your observations in the table.

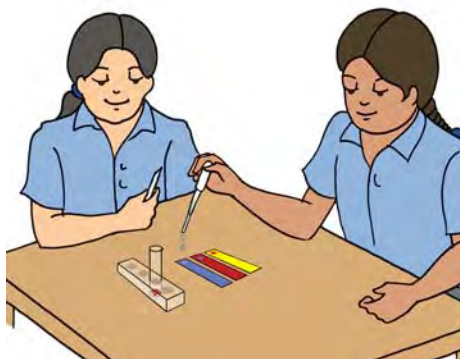

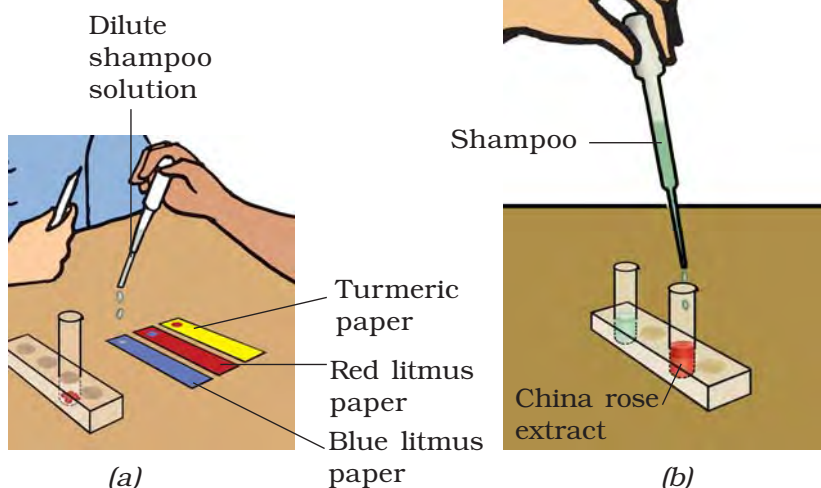

Fig. 7.3.1 Test the acidic, basic or neutral nature of a substance

5. Put 5 drops of shampoo solution into a test tube containing some china rose extract [Fig.7.3.1 (b)].
6. What change in colour do you observe? [Fig.7.3.1 (b)]. Record your observations in the table given below.

Sl. No.	Test Solution	Effect on			
		Red litmus paper	Blue litmus paper	Turmeric paper	China rose extract
1.	Shampoo solution				
2.					
3.					

What have you learnt?

Shampoo is basic in nature because it turns

— Red litmus blue.

— Turmeric paper red.

— China rose indicator green.

Extension

- 1. Test the nature of some more substances like soda water, lemon juice, soap solution, vinegar, sugar solution, common salt, dil. HCl, dil. H₂SO₄, sodium hydroxide, ammonium hydroxide using the above indicators. Record your observations in the given table.*
- 2. Prepare your own natural indicator using red cabbage leaves. Boil the cabbage leaves and strain them to obtain your own natural indicator. What colour does your indicator give with acids and bases?*

ACTIVITY 7.3.2

What happens when an acid is mixed with a base?

What is required?

Dilute hydrochloric acid, sodium hydroxide solution, phenolphthalein, test tube, graduated dropper.

How will you proceed?

1. Take 1 mL of dilute HCl in a test tube using a graduated dropper.
2. Add one drop of phenolphthalein into it and shake the solution. Do you observe any change in the colour of the solution?
3. To the above solution add 1-2 drops of sodium hydroxide solution by a dropper and shake the tube gently. Is there any change in the colour of the solution?
4. Continue adding sodium hydroxide solution dropwise with stirring till you observe the change in colour. Which colour is obtained?

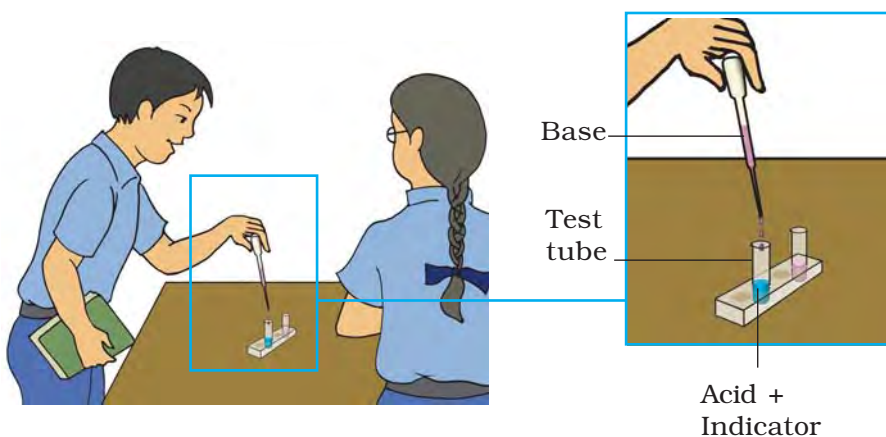

Fig. 7.3.2 Process of neutralisation

5. Now add 1-2 drops of dil. hydrochloric acid.
Do you again observe any change in colour ?
6. Again add 1-2 drops of sodium hydroxide solution.
What happens to the colour of your solution?

What have you learnt?

When an acid solution is mixed with a basic solution both the solutions neutralise each other as indicated by the change in the colour of the indicator. This reaction is known as neutralisation reaction.

Acid + Base \rightarrow Salt + Water

Note that in this reaction, salt and water are obtained as products

Extension

Observe the colour of the acid and base solutions before neutralisation and colour of the neutralised solution after mixing them using red and blue litmus papers.

7.4 PHYSICAL AND CHEMICAL CHANGES

ACTIVITY 7.4.1

How will you get water from ice and ice from water? How will you get water from water vapour?

How will you proceed?

1. Take some ice in a beaker and place it on the tripod stand and heat it with the help of kerosene burner.
2. What do you see? Ice melts to form water.

What is required?

Ice, beaker,
kerosene burner,
watch glass.

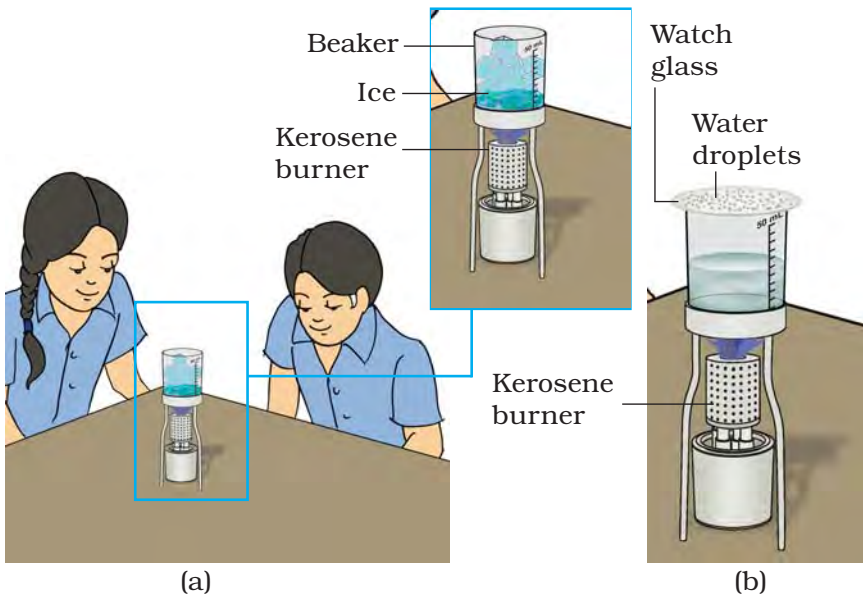

Fig.7.4.1 Ice melts into water on heating and water gets evaporated to form water vapour

3. Can we use this water to get back ice?
4. Suggest a method for it. Can you say that it is a physical change?
5. Take some water in a beaker. Heat the beaker over the kerosene burner. What do you see?
6. Keep a watch glass inverted above the beaker.
7. Do you see some water droplets on the inner surface of the watch glass?
8. You will see the droplets falling back into the beaker.
9. What is this phenomenon called as?

Conclusion

Ice melts to water and water can be frozen back to ice. Water gets evaporated to form water vapours which can condense to form water.

Extension

Think of some way to prove presence of water vapours in air.

ACTIVITY 7.4.2

Is heating of a shaving blade a physical change?

What is required?

Pair of tongs, shaving blade, kerosene burner.

Sometimes a physical change involves change in colour.

How will you proceed?

1. Hold a shaving blade with a pair of tongs over the flame of a kerosene burner.
2. Does the colour of the blade change?
3. Remove the blade from the flame.
4. What do you observe after sometime?

What have you learnt?

The blade becomes red hot on heating. On cooling, the blade regains its original colour. This shows that shaving blade undergoes a physical change on

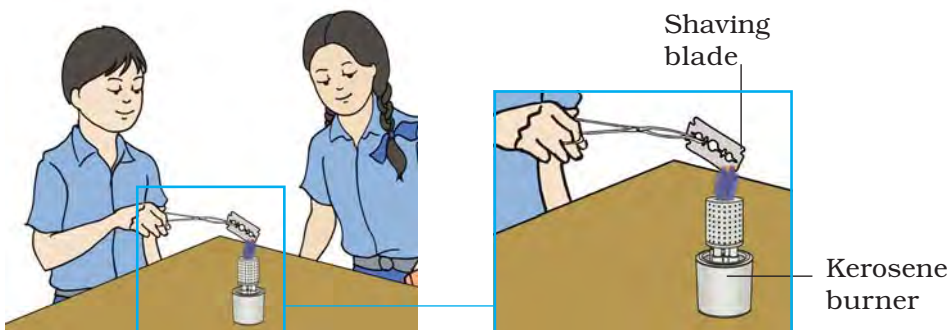

Fig.7.4.2 Heating a shaving blade

heating. Any change in properties such as shape, size, colour and state of a substance is called a physical change. Generally, physical changes are reversible in nature.

Extension

Give a few more instances where change in colour/appearance indicates a physical change.

Notes

ACTIVITY 7.4.3

Is burning of magnesium ribbon a chemical change?

What is required?

Magnesium ribbon, kerosene burner, test tubes, water, phenolphthalein, sand paper, pair of tongs.

A chemical change involves formation of a new substance.

How will you proceed?

1. Take a 5 cm long magnesium ribbon and clean it with a sand paper.
2. Hold it with a pair of tongs over a flame and burn.
3. What is the colour of flame when magnesium ribbon burns? What is left behind when magnesium ribbon is completely burnt?
4. You can see that a white powdery ash is obtained after the burning of the ribbon.

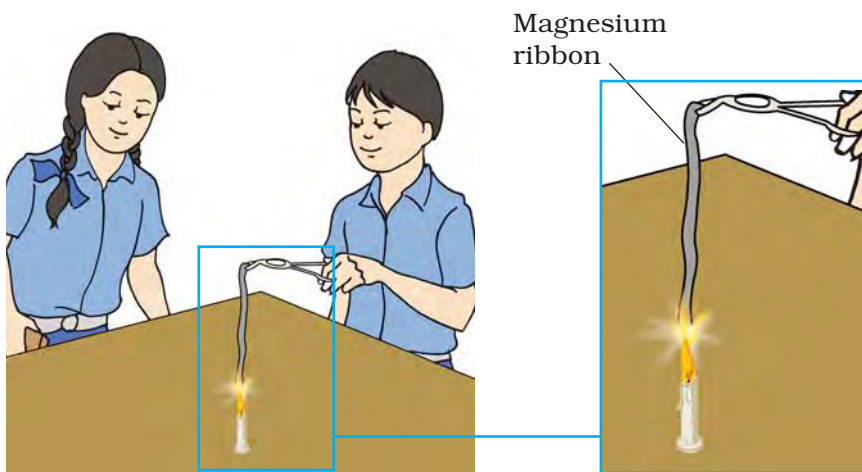

Fig. 7.4.3 Burning of magnesium ribbon

5. Is it a new substance?
6. Collect the white powdery ash and put it in a test tube.
7. Mix it with a small amount of water and stir the mixture well and heat it.
8. Test whether this solution is acidic or basic by adding a drop of phenolphthalein to the solution.
9. Do you see any colour change?
10. What do you conclude?

What have you learnt?

Burning of magnesium ribbon forms a new substance Magnesium oxide. This shows that burning of magnesium ribbon is a chemical change.

Extension

Represent the above chemical change in the form of a chemical equation.

ACTIVITY 7.4.4

To study the nature of change when zinc is added to copper sulphate solution?

What is required?
Copper sulphate,
test tube, zinc
granules, spatula.

How will you proceed?

1. Dissolve a spatula full of copper sulphate in 2 mL of water in a test tube.
2. Add 1 or 2 zinc granules into it and keep it for some time.
3. Do you observe any change in colour of the solution and zinc granules?
4. You will observe that the zinc granules turn brown and after sometime, the solution turns colourless.
5. What may be the possible reason for change in colour?
6. The change in colour of zinc granules is due to the deposition of copper on it. The change in colour of the solution is due to the formation of a new substance, zinc sulphate which is colourless.

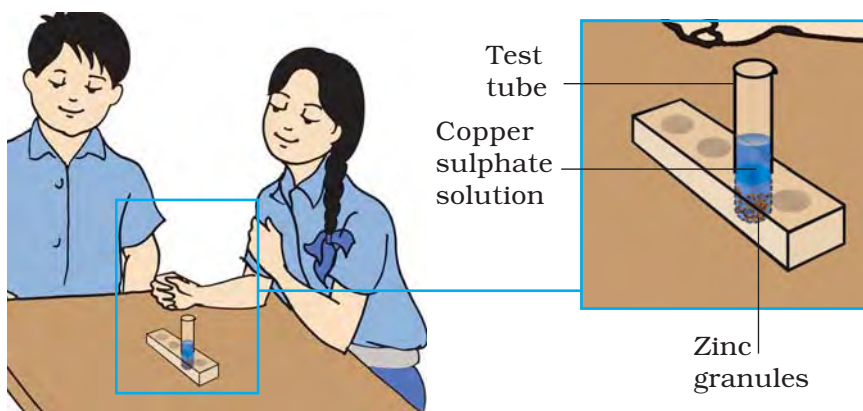

Fig. 7.4.4 Studying the nature of change in a test tube when zinc is added to copper sulphate solution

What have you learnt?

The reaction between zinc granules and copper sulphate involves formation of two new substances, i.e., zinc sulphate and copper (brown). Thus, this process is a chemical change.

Extension

Write the reaction between zinc granules and copper sulphate in the form of a chemical equation.

Notes

ACTIVITY 7.4.5

To study the type of change when vinegar is added to baking soda ?

What is required?

Vinegar, baking soda, spatula, lime water, W-tube, dropper.

How will you proceed?

1. Take a W-tube and add a pinch of baking soda from the left side tube.
2. Take a few drops of limewater in a dropper and add to the right side of the W-tube.
3. Take a few drop of vinegar (acetic acid) in the dropper and fix the dropper at the mouth of the left side tube.
4. Why is the tube blocked with the dropper?
5. Start adding vinegar dropwise to the baking soda.
6. Do you see bubbles of gas coming out?
7. What happens to the lime water?

You will notice that the lime water turns milky.

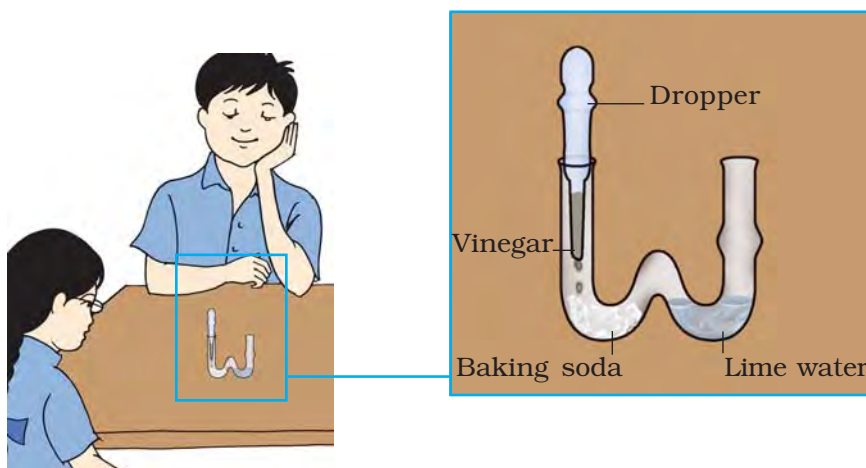

Fig.7.4.5 Chemical changes in W-tube

What have you learnt?

- 1. The reaction between vinegar and baking soda produces carbon dioxide gas which when passed through lime water, turns it milky.*
- 2. This reaction involves the formation of new substances. Therefore, it is a chemical change.*

Notes

Activity 7.4.6

How do you get the crystals of copper sulphate from its solution?

What is required?

Beaker, copper sulphate powder, dil. H_2SO_4 , water, glass rod, filter paper, funnel, tripod stand, kerosene burner, G-clamp, china dish.

How will you proceed?

1. Take 5 mL of water in a china dish.
2. Add sufficient amount of copper sulphate powder to get a saturated solution.
3. Add a few drops of dil. H_2SO_4 to this solution.
4. Heat the solution on the kerosene burner and continue adding copper sulphate till no more powder can be dissolved.
5. Allow the solution to cool for sometime.

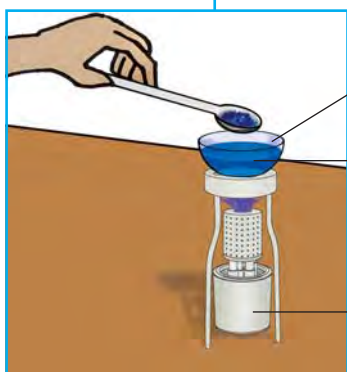

China dish
Copper Sulphate Solution

Kerosene burner

Beaker

(a)

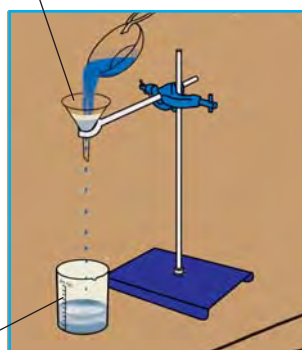

Funnel

Fig. 7.4.6 Arrangement to show the crystallisation

6. Filter the contents of china dish in a beaker to get a clear solution.
7. Keep the solution for cooling for some time without disturbing it.
8. What do you observe after sometime ?

What have you learnt?

Crystals of copper sulphate are obtained by crystallisation of the copper sulphate solution.

*Crystals of pure substances can be obtained from their solutions. This process is called **crystallisation**.*

Notes

7.5 WIND, STORMS AND CYCLONE

Activity 7.5.1

How can we show that air expands on heating and contracts on cooling?

What is required?

A test tube, a rubber cork with one hole, a long fine glass tube, a rubber tube, some coloured water, a wax candle, match box, beaker and water.

How will you proceed?

1. Take a test tube .
2. Fit a one-holed cork on its mouth.
3. Insert tightly a fine glass tube through this hole [Fig. 7.5.1]. Put a little molten wax through the gap in between the cork and glass tube to make the assembly air tight.
4. Insert a drop of coloured water ink, KMnO_4 through the glass tube.
5. Now hold the test tube in the bright Sun or heat it gently at the end using a candle flame.

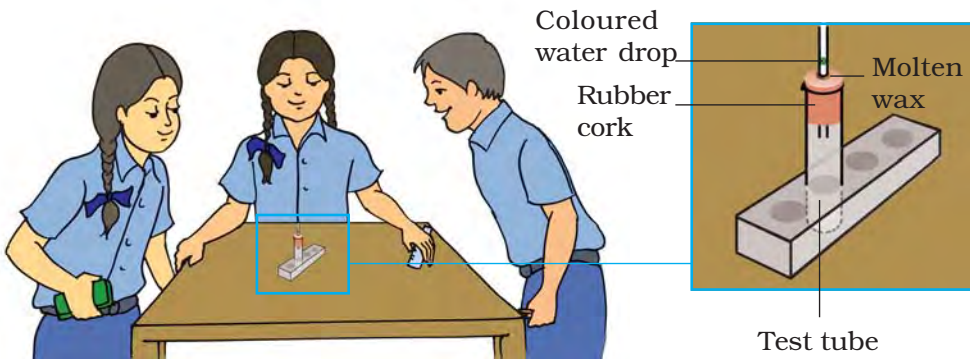

Fig.7.5.1 Arrangement to show expansion of air

6. Observe the motion of the water drop in the glass tube. What happens to it?
7. Now keep the test tube in shade.
8. Observe the motion of water drop in the glass tube again.
9. What happens to the water drop if the test tube is placed in ice cold water?

What have you learnt?

Air expands on heating and contracts on cooling.

Extension

Make a slight alteration in the above arrangement. Instead of taking a drop of coloured water in the glass tube, connect one end of the rubber tube to the open end of the glass tube. Immerse the other end of the rubber tubing in water taken in a beaker. Now repeat the activity. Observe the beaker. What happens now? Why?

Activity 7.5.2

How can we show that air exerts pressure?

What is required?

A very thin walled plastic bottle, hot water, cold water.

How will you proceed?

1. Take a very thin walled plastic bottle.
2. Pour small quantity of hot water into it.
3. Shake it well.
4. Pour out the hot water and close the lid of the bottle immediately.
5. Now pour cold water over the bottle.
6. Observe what happens.
7. Try to find the reason for your observations.
8. Now open the lid of the bottle.
9. What happens now?

What have you learnt?

Air exerts pressure.



Fig.7.5.2 Bottle with hot water deformed when cooled

ACTIVITY 7.5.3

How can we show that the air pressure gets reduced when air blows?

*What is required?
A funnel, a plastic ball.*

How will you proceed?

1. Take a funnel.
2. Blow through the stem keeping the funnel vertically upwards.
3. Now take a plastic ball and place it inside the funnel.
4. Now blow air through the funnel.
5. Does the ball rise up?
6. Now invert the funnel.
7. Hold the plastic ball in your hand just below the mouth of the stem of the funnel.
8. Blow air through the stem of the funnel and remove your hand.
9. Does the ball fall? Try to find the reason?

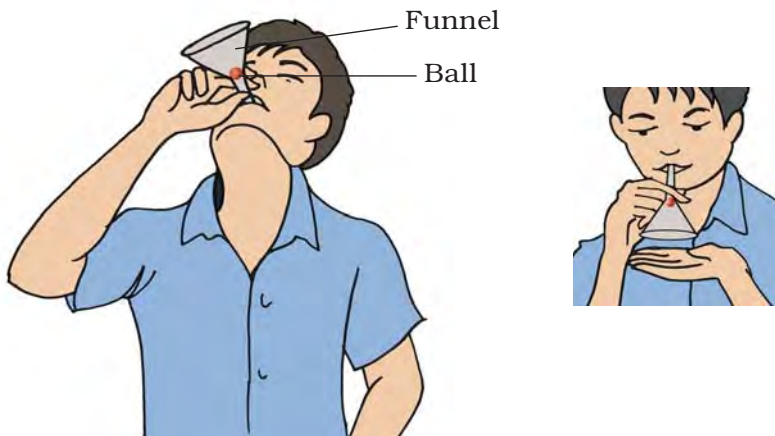

Fig.7.5.3 Arrangement to show air pressure

10. The air pressure, when we blow through the stem, decreases at the mouth of the stem than in the wider portion of the funnel.

What have you learnt?

The air pressure decreases at the mouth of a nozzle when air is blown through it.

Notes

7.6 SOILS

ACTIVITY 7.6.1

How will you show that the soil collected from different places differ in composition?

- Soils are classified on the basis of humus content and particle size.
- The various types of soils are sandy, clayey and loamy soil.

What is required?

Soil samples (from garden, fields), watch glass, glass rod and tumblers (50 mL beaker).

How will you proceed?

1. Take two tumblers, each filled $2/3^{\text{rd}}$ with water.
2. Add about 10 spoons of soil samples separately in each of them.
3. Stir them well with a glass rod.

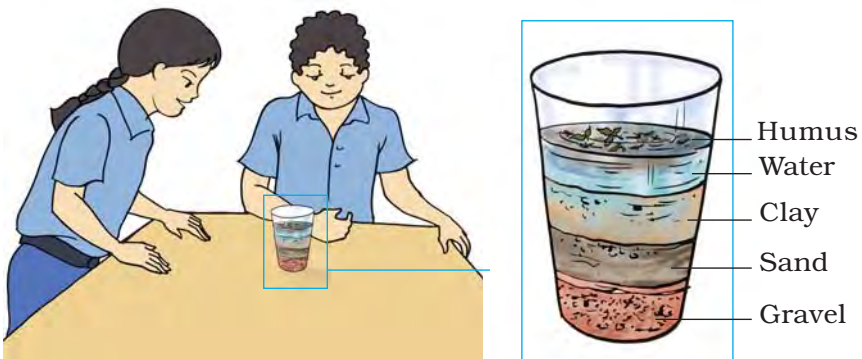

Fig. 7.6.1 Different layers of soil

4. Leave these tumblers undisturbed for sometime. Do you see different layers [Fig. 7.6.1].
5. Are the layers similar in the tumblers?

What have you learnt?

Soils from different places contain different amounts of gravel, sand, clay and humus.

Extension

Repeat the experiment with different soil samples.

Notes

ACTIVITY 7.6.2

How will you show the presence of water in soil?

What is required?

One borosil test tube (15mL), test tube holder, G-clamp, kerosene burner and soil sample.

How will you proceed?

1. Take some soil in a borosil test tube and heat it on a burner with the help of a holder.
2. Do you observe water vapours? Do you see water droplets on the inner side of the test tube?

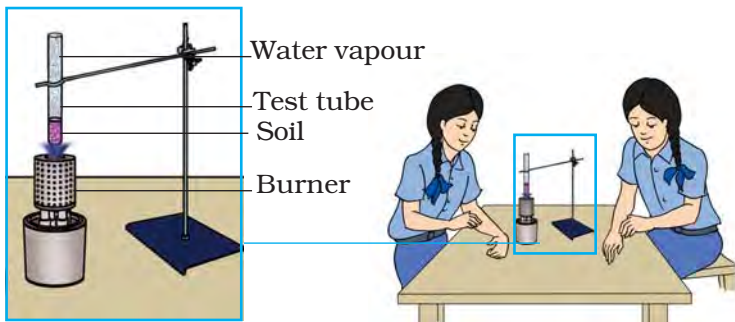

Fig. 7.6.2 Water is present in soil sample

What have you learnt?

Soils contain water. On heating, the water of the soil gets evaporated and soil becomes loose.

Extension

Carry out the above activity with some more soil samples and compare their water contents.

ACTIVITY 7.6.3

How will you show that different types of soils have different water holding capacity?

What is required?

Plastic funnels, beakers, filter paper, dropper, and measuring cylinder.

How will you proceed?

1. Take equal amounts of the three types of soil, viz., sandy, clayey and loamy.
2. Dry them and keep in separate funnels A, B and C lined with wet filter paper.
3. Place these funnels on measuring cylinders.
4. Gradually pour 100 mL of water in each funnel.
5. After about one hour, read the level of water in the cylinder.

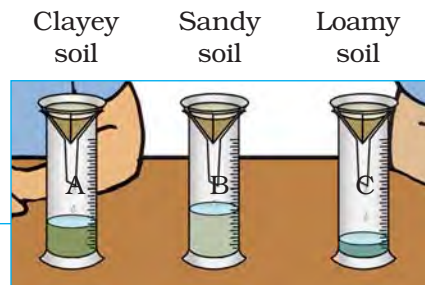
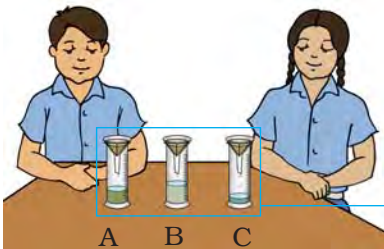

Fig. 7.6.3 Water holding capacity of clayey, sandy and loamy soil

6. Record your observations in a table as given below:

	Setup A (with clay)	Setup B (with sand)	Setup C (with loam)
Volume of filtered watermLmLmL

Conclusion

1. Funnel A has passed.....mL water (fill in the blanks by actual reading and calculations) and retained.....mL. The amount of water retained is more than that has passed. Thus, we can say that clay has more water-holding capacity.
2. Funnel B has passedmL of water at a faster rate due to the large size of particles and bigger air spaces in-between. Thus, the sandy soil has very little water retention capacity (.....mL).
3. Funnel C has passed more water than in A and less than in B due to mixture of sand and clay. It also contains humus which retains water. It has retained a moderate quantity of water (.....mL).

What have you learnt?

Texture of soil depends upon the size and arrangement of soil particles. Soils can be classified into different types on the basis of size of soil particles and spaces present in-between which decides its water holding capacity.

Extension

Repeat the above activity with other type of soil and calculate the percentage of water absorbed.

7.7 RESPIRATION IN ORGANISMS

ACTIVITY 7.7.1

How to demonstrate the presence of CO_2 in air we breathe out?

The air we breathe in is a mixture of gases. The air we breathe out contains a higher amount of CO_2 (approx.4.4 per cent and water vapours) as compared to the air we breathe in (approx.0.04 per cent). Respiration is a cellular process resulting in the liberation of energy, whereas breathing is simply the exchange of gases between the organism and the atmosphere.

What is required?

Two test tubes, a Y-shaped tube, two rubber corks each with a hole, lime water and tap water.

How will you proceed?

1. Take two test tubes.
2. Take some freshly prepared lime water, in one test tube.
3. Take the same quantity of tap water in second test tube
4. Insert the two ends of the Y-shaped tube into the test tubes so as to dip the ends of the limbs in the liquids.
5. Now, blow out gently through the median limb of Y-shaped tube a few times.
6. Do you observe any change in the colour of lime water and tap water in the two test tubes?

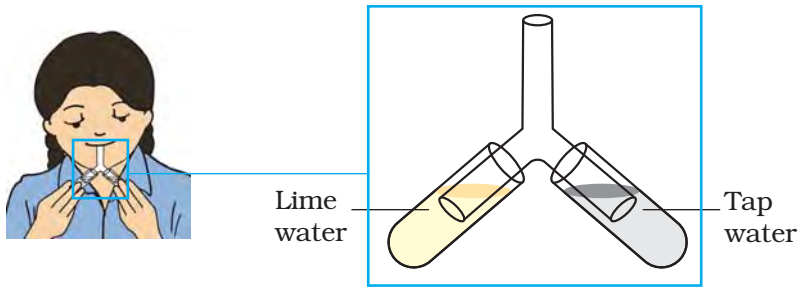

Fig. 7.7.1 Carbon dioxide is present in the air we breathe out

What have you learnt?

When we blow into the lime water, it turns milky.

Can you give reasons?

Extension

- 1. Blow out a few times on the surface of a mirror. Now, release some air on the surface of another mirror through cycle pump. Did you find any difference? Give reasons.*
- 2. Whenever we are sleepy or in a state of low activity, we generally yawn. Can you give the reasons?*
- 3. During severe winters, when we exhale, a mist of white smoke comes out from our mouth. Find out the reasons.*
- 4. In a crowded and closed area, we often feel suffocated. Why?*

ACTIVITY 7.7.2

What is the role of diaphragm in breathing?

What is required?

A glass or plastic 'Y' tube, bell jar with air tight cork having a hole at the centre, two small balloons, a thin rubber sheet or a big balloon.

Breathing means inhalation and exhalation of air. Lungs are the main breathing organs which are situated in the chest cavity surrounded by the ribs. A large muscular sheet, the diaphragm is present below the lungs which forms the floor of the chest cavity. Movement of the diaphragm helps in breathing.

How will you proceed?

1. Take a plastic or glass 'Y' tube.
2. Fix two deflated balloons to the forked ends of the 'Y' tube.
3. The 'Y' tube is kept in inverted position and is inserted into the hole of the cork from top side.
4. Fix the cork in the mouth of the bell jar.
5. Tie a thin rubber sheet or a split balloon is fitted on the open end of the bell jar with the help of a rubber band.
6. Pull the rubber sheet down from the base downward, you will see that the balloons at the forked ends swell up.
7. Push the rubber sheet up. The balloons will shrink.
8. The balloons in the apparatus represent lungs and the bell jar, the chest cavity. The rubber sheet represents the diaphragm.

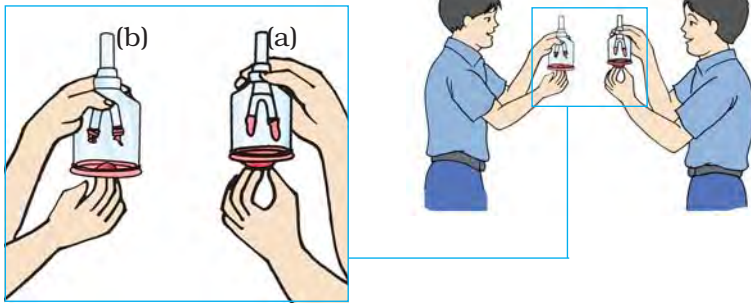

Fig.7.7.2 Model to show mechanism of breathing

What have you learnt?

During inhalation, ribs move up and outwards, and diaphragm moves down to increase space resulting in the increase of volume in the chest cavity and air rushes into the lungs. The lungs get filled with air.

During exhalation, the ribs move down and inwards while diaphragm moves up. This reduces the volume of the chest cavity and increases the pressure on the lungs, with the result that the air is pushed out of the lungs.

Extensions

1. With the help of a measuring tape, measure the chest size of your classmates during breathing.
2. Observe the breathing in fishes and compare it with other organisms.

7.8 TRANSPORTATION IN ANIMALS AND PLANTS

ACTIVITY 7.8.1

How can you listen to your own heart beat?

What is required?

Funnel (6-7 cm in diameter), rubber tube (50cm), rubber sheet or balloon.

You can feel your heart beat if you place your one hand on the left side of your chest. But can you hear it? The stethoscope is a device which amplifies the sound. Let us construct our own stethoscope.

How will you proceed?

1. Take a small funnel and fix the rubber tube tightly on the stem of the funnel.
2. Stretch a rubber sheet or a balloon on the mouth of the funnel and fix it tightly.

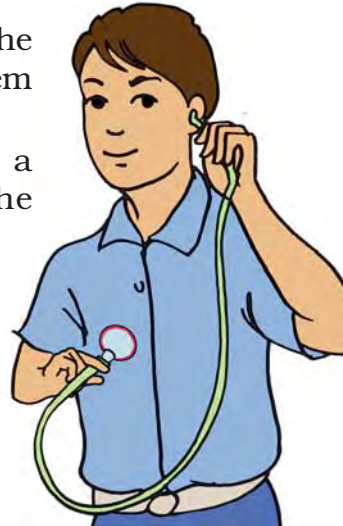
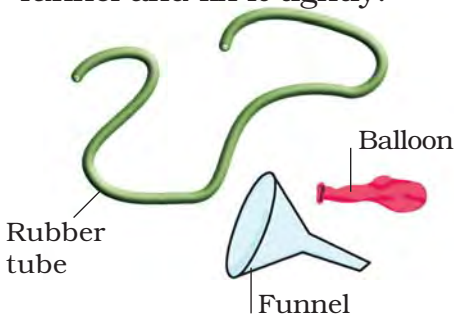

Model of stethoscope

- Put the open end of the tube on one of your ears and place the mouth of the funnel on your chest over the heart. Do you hear any sound?

What have you learnt?

The regular thumping sound that you hear is the heart beat . Normally the heart beats 72 times a minute in an adult.

Notes

ACTIVITY 7.8.2

How does water move from one cell to another in plants?

What is required?

Potato, 3 per cent sugar/salt (3gm in 100 mL) solution, petridish, knife or scalpel and pin.

How will you proceed?

1. Take a large potato and peel off its outer skin.
2. Give two cuts on opposite sides to make two flat bases.
3. Make a deep and hollow cavity on one of the flat surface leaving only a thin base.
4. Fill half of the cavity with 3 per cent sugar solution and mark the level by inserting a pin in the wall of the potato from inside the hollow cavity.
5. Put the potato in a petridish containing some water and the level of water should be below the level of the pin.
6. Allow the apparatus to stand for a few hours.
7. You will observe an increase in the level of sugar solution inside the cavity of the potato.

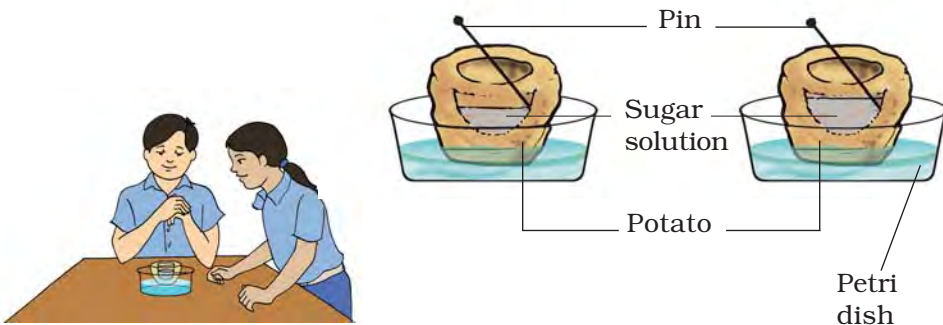

Fig. 7.8.2 *Water moves through different cells of potato through osmosis*

What have you learnt?

Water moves from a region of lower sugar concentration to the region of higher sugar concentration across a membrane. By this method plants absorb water and minerals by the roots. The roots have root hair. The root and hair absorb the water present in the soil and transport it to other parts of the plant.

Extension

Take thick peels of potatoes, cucumber or any other vegetable. Put them in water. The peels will curve showing absorption of water by cut end.

7.9 REPRODUCTION IN PLANTS

ACTIVITY 7.9.1

How does asexual reproduction occur in plants?

What is required?

Yeast powder, 10 per cent sugar (10 gms sugar in 100mL of water) solution, glass beaker, glass rod, slide, cover slips, dropper, microscope.

In asexual reproduction, plants give rise to new plants without seeds. Only a single parent is involved. Budding is one of the processes of asexual reproduction.

How will you proceed?

1. Fill one-fourth of a beaker with 10 per cent sugar solution and add a pinch of yeast powder or one half powdered yeast tablet to it.
2. Keep it in the warm place of the room for an hour.
3. Now put a drop of this liquid on a glass slide and put a coverslip. Observe under the microscope under high power.
4. You will observe small bulb-like projections coming out of the yeast cells. These are called buds.
5. The buds gradually grow and may get detached from the parent cell or result in a chain of buds.
6. The new yeast cell grow, mature and produce more yeast cells.

What have you learnt?

1. The process you observed is called **budding**.
2. Budding is a kind of asexual reproduction. In this process single parent is involved and new plants are produced without seeds.

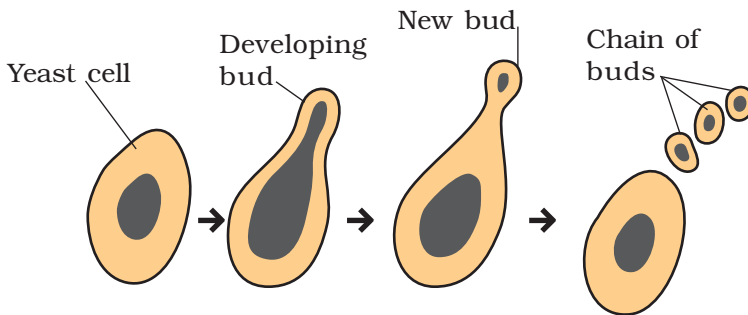

Fig. 7.9.1 Asexual reproduction in yeast by budding

Extension

Observe the methods of propagation of potato, sugarcane, ginger bryophyllum, etc.

7.10 MOTION AND TIME

Activity 7.10.1

How can we determine the time period of a simple pendulum?

What is required?

Pendulum bob, stop watch or wrist watch, G-clamp with rod, about 1.5 m long cotton thread, a piece of chalk.

How will you proceed?

1. Fix the G-clamp at the edge of a table as shown in Fig.7.10.1. Insert the iron rod in the hole of the G-clamp and tighten the screw.
2. Tie one end of the thread to the hook of the bob and suspend the bob from the rod of G-clamp making a knot in the thread.

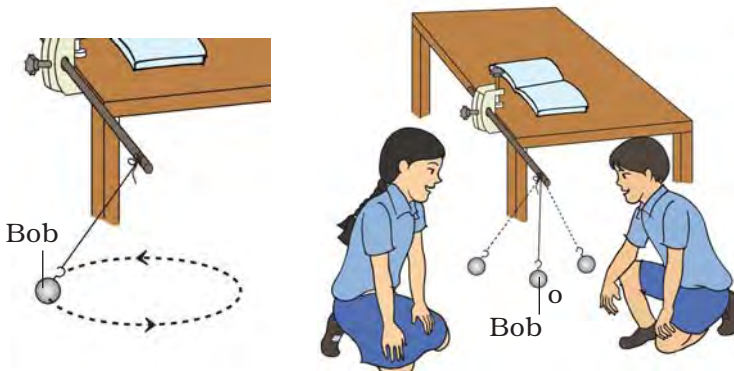

(a) A simple pendulum

(b) Different positions of the bob

Fig. 7.10.1 Oscillation of a simple pendulum

3. Let the bob come to rest in its mean position say at O. Mark this position on the ground as shown in Fig.7.10.1.
4. Displace the bob slightly to one side from its mean position and then release it gently.
5. Measure the time for 20 oscillations with the help of a stop watch or wrist watch.
6. Divide this by 20, to get time for one oscillation.
7. Repeat the steps No. 5 and 6 at least three times by displacing the bob slightly more, i.e. by increasing 2 cm each time from the mean position.
8. Does the time period of the pendulum depend on the displacement of the bob from its mean position?

What have you learnt?

Time period of a given simple pendulum is always the same and it does not depend on the displacement of the bob from its mean position provided this displacement is not very large.

Extension

Repeat this activity by changing the length of the thread say, from 50 cm to 150 cm and determine the time period in each case.

Is the time period same in both the cases?

If possible, change (a) the diameter, (b) mass of the bob and find the factors on which the time period of a simple pendulum depends.

Activity 7.10.2

How can we find the speed of a normal walk?

What is required?

A measuring tape, stop watch and a piece of chalk.

How will you proceed?

1. Mark a straight line of length 50 m in an open space with the help of a measuring tape.
2. Ask one of your friend to start walking on this line with his normal gait/walk and simultaneously start the stop watch.
3. Stop the stop-watch at the moment when your friend reaches the other end of the straight line.
4. Measure the time taken by your friend to travel the distance of 50 m.
5. To find the speed of the normal walk of your friend divide 50 m by the time taken(in seconds) to travel this distance.
6. Repeat this activity (steps 2 to 5) with as many friends as possible .
7. Find the average of the above speeds to determine the average speed of a normal walk.

What have you learnt?

Average speed can be determined by dividing the total distance travelled with the total time taken to travel it.

Activity 7.10.3

How can we measure time with the help of a sun-dial?

What is required?

sun-dial, compass needle and a piece of chalk.

How will you proceed?

1. Place the compass needle in an open space where you can get sunshine throughout the day.
2. Mark a line along N-S direction.
3. Replace the compass needle by the sun-dial.
4. Rotate the sun-dial in such a way that its gnomon is along the N-S direction.
5. Note the time on the sun-dial scale where the shadow points.
6. Compare this time with your wrist watch.

What have you learnt?

size and position of the shadow of an object can be used to measure time.

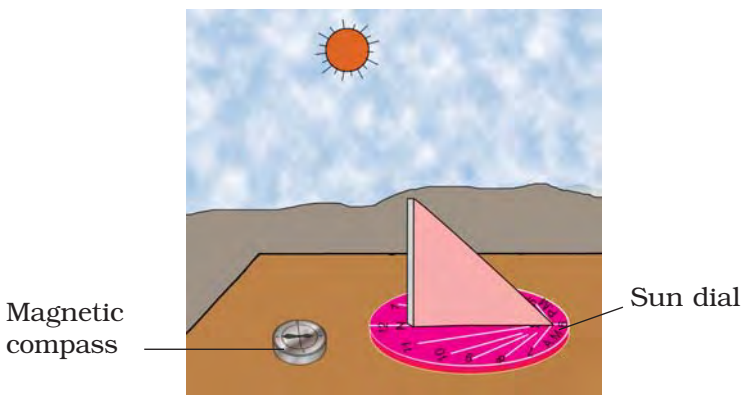

Fig. 7.10.1 A Sun dial

Extension

For exact measurement of time the gnomon of the sun-dial should be kept in geographical N-S direction. Here we have placed the sun-dial in the magnetic N-S direction.

The geographical N-S direction is inclined with the magnetic N-S direction with an angle which varies from place to place.

Try to locate the geographical N-S direction at your place.

Notes

7.11 ELECTRIC CURRENT AND ITS EFFECT

Activity 7.11.1

How can we show that a current flowing through a conductor produces heating effect?

What is required?

Different resistors, connecting wires having crocodile clips at both ends, sand paper and generator.

How will you proceed?

1. Connect the resistor between two terminals of the generator using connecting wires having crocodile clips [Fig.7.11.1].
2. Rotate the coil of the generator at a moderate speed for about 30 seconds.
3. Check the hotness of the resistor just by touching it.

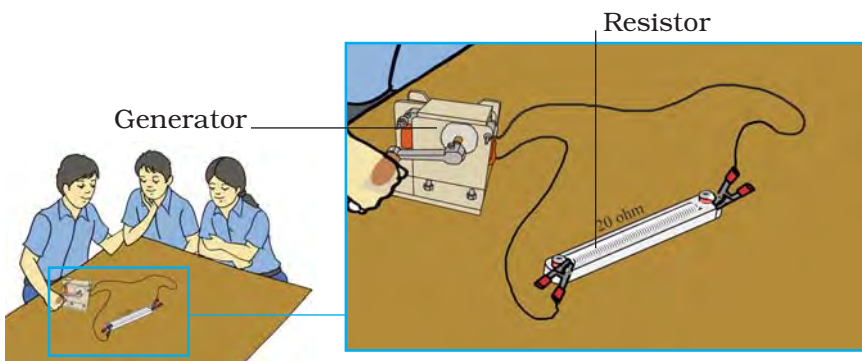

Fig. 7.11.1 Generator connected to a resistor

4. Replace the resistor by another resistor and pass current through it for almost the same time by rotating the generator.
5. Check the hotness of the resistor again.
6. Repeat this activity with two or three other resistors. What conclusion can you draw from this activity.

What have you learnt?

When electric current passes through a wire , it produces heating effect.

Notes

ACTIVITY 7.11.2

How can we show that an electric current flowing through a conductor produces magnetic effect around it.

How will you proceed?

1. Connect the metallic wire to a dry cell with a switch using connecting wires having crocodile clips at the two ends.
2. Place the compass needle near to the metallic wire [Fig.7.11.2].
3. Now close the switch and observe the deflection of the compass needle.
4. Open the switch and again observe the needle of the compass whether it deflects again to come back to its initial position or not.

What is required?

A metallic wire, dry cell/generator, switch, magnetic compass, connecting wires having crocodile clips at its ends and sand paper.

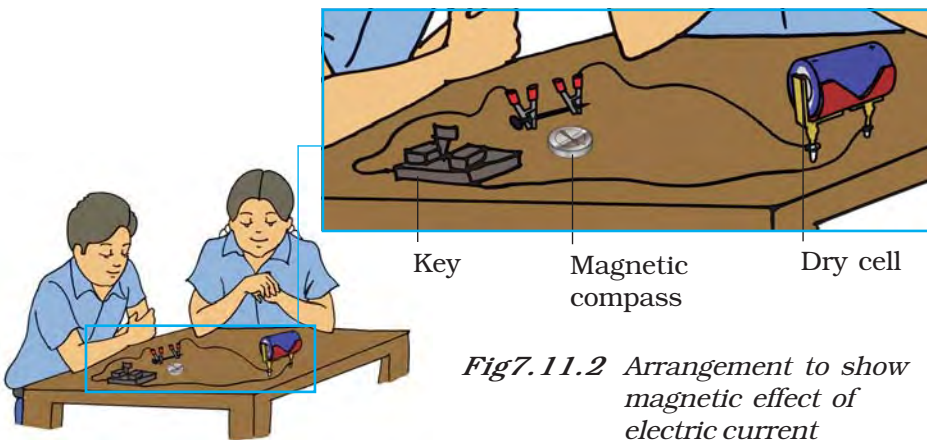

Fig7.11.2 Arrangement to show magnetic effect of electric current

5. Repeat steps 3 and 4 two times and draw conclusion.
6. The deflection of the needle shows that current carrying conductor acts as a magnet.

What have you learnt?

When electric current passes through a wire, it produces magnetic effect.

Extension

Repeat this activity using generator in place of dry cell.

Notes

ACTIVITY 7.11.3

How can we make an electromagnet?

What is required?

A long iron nail, insulated copper wire, a cell/generator, iron filings, compass needle, connecting wires having crocodile clips at the two ends, switch and sand paper.

How will you proceed?

1. Take a long iron nail.
2. Check whether it is already a magnet or not, by dipping it in iron filings. Make sure that it is not a magnet.
3. Now wind an insulated copper wire over the nail.
4. Remove the enamel at the ends of the insulated copper wire using sand paper.
5. Connect the ends of the insulated wire to a switch and then to the cell or generator [Fig.7.11.3].
6. Now dip the nail in iron filings. What do you observe?
7. Do the iron filings cling to the tip of the nail?
8. Now switch off the current. Are the iron filings still clinging to the nail in the same way?

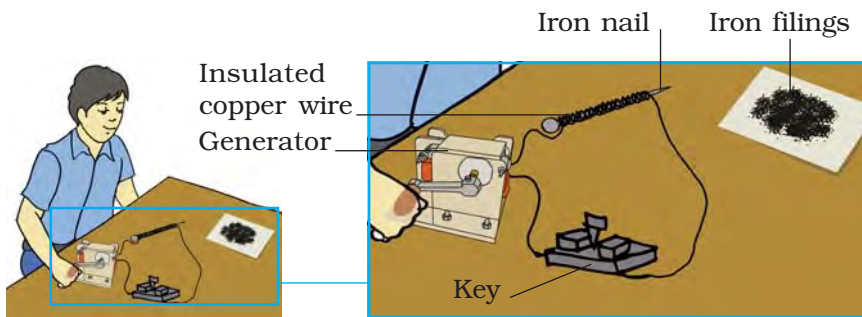

Fig.7.11.3 An electromagnet

9. Repeat steps 5 to 8 of the activity atleast two more times. What conclusion can be drawn by this activity?

What have you learnt?

When current is passed through a wire wrapped on an iron nail, the nail becomes a magnet. This arrangement is called electromagnet.

Extension

Repeat the above activity by increasing the number of turns, wound on the nail. Find out how the strength of an electromagnet changes with the number of turns wound on the nail.

Notes

7.12 LIGHT

Activity 7.12.1

How can we identify different types of lenses and mirrors?

What is required?

Plane mirror, convex mirror, concave mirror, convex lens, concave lens, connecting wires with crocodile clip at both ends and sand paper.

How will you proceed?

1. Place the given mirrors and lenses on the table and observe them one by one. On the basis of their look and properties classify them into following two groups:
 - (a) Polished/shining/opaque surfaces having same thickness throughout. These are mirrors.
 - (b) Unpolished, transparent, curved surfaces having different thickness. These are lenses.
2. Take the mirrors and examine their shining surfaces.
 - (a) If the shining surface is plane, it is a plane mirror.
 - (b) If the shining surface is curved outside, it is a convex mirror.
 - (c) If the shining surface is curved inside, it is a concave mirror.
3. Now take the lenses and examine them.
 - (a) If both the surfaces are curved outside, it is a double convex lens.

(b) If both the surfaces are curved inside, it is a double concave lens.

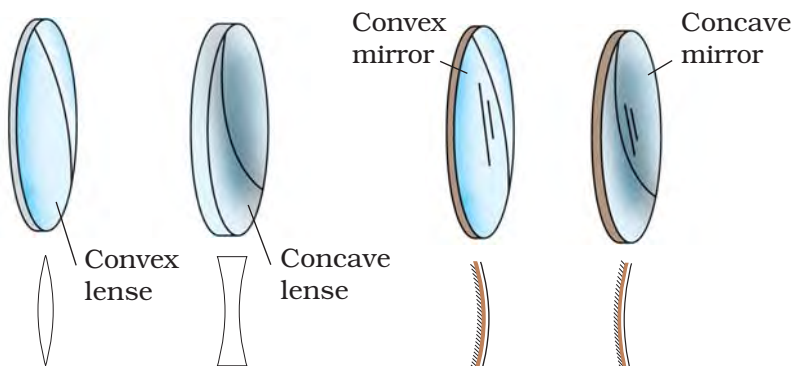

Fig. 7.12.1 Different types of mirrors or lenses

What have you learnt?

Mirrors and lenses can be identified by observing them.

Extension

Connect ray streak apparatus to the generator with the help of connecting wires having crocodile clips. Place this arrangement on a white sheet. Rotate the handle of the generator to glow the bulb. When the bulb glows a parallel beam of light is seen in the ray streak apparatus.

Place the mirrors one by one in the path of the parallel beam and observe the nature of the reflected beam in each case.

- If the reflected beam is parallel it is a plane mirror.
- If the parallel beam after reflection from the polished surface meets at a point (converges) in front of the surface, it is a concave mirror.
- If the parallel beam after reflection from the polished surface, appears to diverge from a point behind the surface (mirror), it is a convex mirror.

Place the lenses in the path of the parallel beam of light and observe the nature of the beam after passing through the lens.

- If the parallel beam of light after passing through the lens meets (converges) at a point on the other side of the lens, it is a convex lens.
- If the parallel beam of light after passing through the lens appears to come from a point on the same side as the incident beam, it is a concave lens.

Activity 7.12.2

How can we find the nature of the image formed by a concave mirror?

What is required?

Concave mirror,
candle, match box
and thick sheet of
white paper.

How will you proceed?

1. Light a candle.
2. Fix a concave mirror on the stand and place its reflecting side at a distance of about 25 cm from the candle. Ensure that the mirror surface is perpendicular to the ground.
3. Hold a thick sheet of white paper (or a screen) on the other side of the candle (behind the candle) keeping its plane parallel to the mirror surface .
4. What do you see on the screen?
5. If nothing is visible except a dim patch of light, move the screen a little forward or backward in line with the concave mirror and the candle, till you obtain on it a clear image of the flame.
6. Now shift the candle towards the mirror to a distance of about 2-3 cm and again obtain the image of the candle flame on the white screen as done previously.

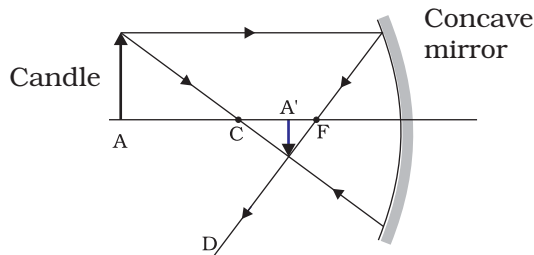

Fig 7.12.2 Nature of image formed by a concave mirror

7. Repeat step No. 6 three to four times by shifting the candle towards the mirror and observe the image in each case.
8. Again repeat the activity by shifting the candle away from the mirror and observe the image on the screen in each case.
9. What inferences could you draw from the above observations?
10. Now on the basis of your observation try to answer the following questions.
 - Whether the image is always obtained on the screen?
 - Whether the image formed is always (a) enlarged and; (b) diminished in size?
 - Whether the image formed is always inverted?

What have you learnt?

The image due to a concave mirror can be:

(a) real or virtual

(b) enlarged or diminished

(c) erect or inverted

Activity 7.12.3

How can we find the nature of the image formed by (a) convex lens
(b) concave lens?

How will you proceed?

1. Fix a convex lens on the stand and place it on the table in such a manner that its surface is perpendicular to the table.
2. Light the candle and keep it in front of the lens.
3. Hold a sheet of white paper (or a screen) on the other side of the lens. What do you see on it?
4. If nothing is visible, move the sheet forward or backward in line with the lens and the candle until you obtain a sharp and clear image of the flame on the screen.
5. Now shift the candle towards the lens to a distance of about 2 cm and again obtain the image of the candle flame on the screen.

What is required?

Concave lens, convex lens, candle, match box, lens-stand, thick sheet of white paper (or a screen).

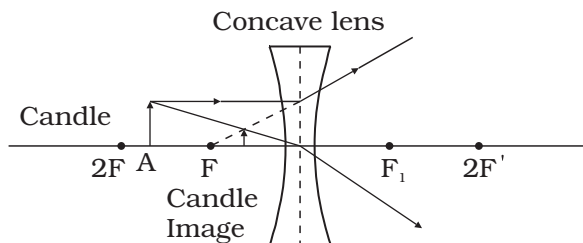

Fig. 7.12.3 (a) Nature of the image formed by a concave lens

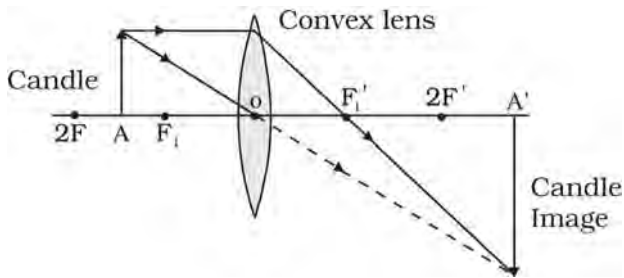

Fig. 7.12.3(b) Nature of the image formed by a convex lens

6. Repeat step No. 5 three to four times by shifting the candle towards the lenses and observe the image in each case.
7. On the basis of your observations, now try to answer the following questions:
 - Whether the image is always obtained on the screen ?
 - Whether the image is always erect or inverted?
 - Whether the image is always enlarged or diminished?
8. What inferences do you get from the above observations?
9. Repeat the activity with a concave lens and make inferences.

What have you learnt?

1. Nature of the image depends on the distance between the object and the lens in case of a convex lens.
2. Whatever may be the position of the object with respect to the lens it is not possible to get the image on the screen in the case of a concave lens.

Activity 7.12.4

How can we find the composition of white light?

What is required?

White card sheet of size 10 cm x 10 cm, water colour or coloured pencil box, scale, scissors, compass and generator.

How will you proceed?

1. Take the white card sheet.
2. Draw a circle of 10 cm diameter on it and cut a circular disc out of the card sheet.
3. Divide the circular disc into seven equal sectors/parts using the scale.
4. Use the water colour to colour the sectors in the order violet, indigo, blue, green, yellow, orange and red.
5. Make a hole at the centre of the disc such that a pencil head/axle can pass through it. The disc is now ready for use.
6. Sharpen the pencil and insert its tip into the hole such that the pencil protrudes partly out of it and the coloured face of the disc is vertical.



Fig. 7.12.4 (a) A disc with seven dours
(b) It appears white by rotating

7. Hold the pencil from the top with its tip towards you. Now rotate it in daylight so that the disc attached to it also rotates rapidly. What do you observe?
8. What is the colour of the disc while it rotates?
9. Alternatively, what conclusion can you draw from this activity?

What have you learnt?

White light is composed of seven colours.

Notes

Activity 7.12.5

How can we split sunlight into different colours?

What is required?

Plane mirror,
transparent tumbler
and water

How will you proceed?

1. Take a plane mirror of suitable size.
2. Place it in a tumbler as shown in Fig.7.12.5.
3. Fill the tumbler with water.
4. Place the tumbler near a window such that the direct sun rays falls on the mirror.
5. Adjust the position of the tumbler such that the reflected light from the mirror falls on a nearby wall.

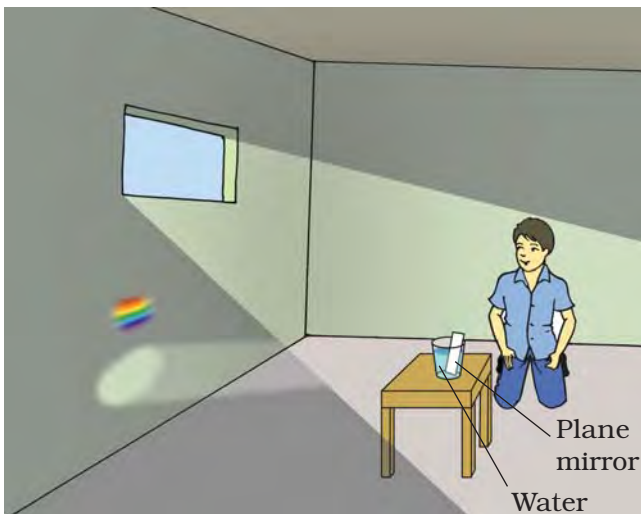

Fig. 7.12.5 Splitting of the sunlight into its constituent colours

6. Place a white sheet of paper at this place of the wall.
7. What colours do you see on the white sheet.
8. Now disturb the water and observe the white sheet. Are the colours still there? If yes, why?
9. As water settles do you again see the colours? If yes, why?

What have you learnt?

-
1. *Sunlight can be splitted into different colours.*
 2. *The above arrangement works as a water prism.*
-

Notes

UPPER PRIMARY SCIENCE KIT MANUAL

FOR CLASS VIII

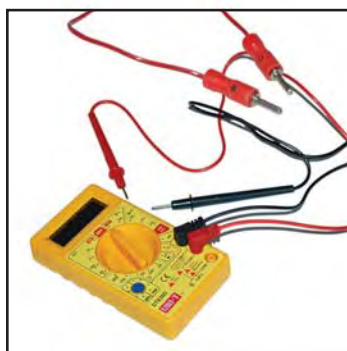
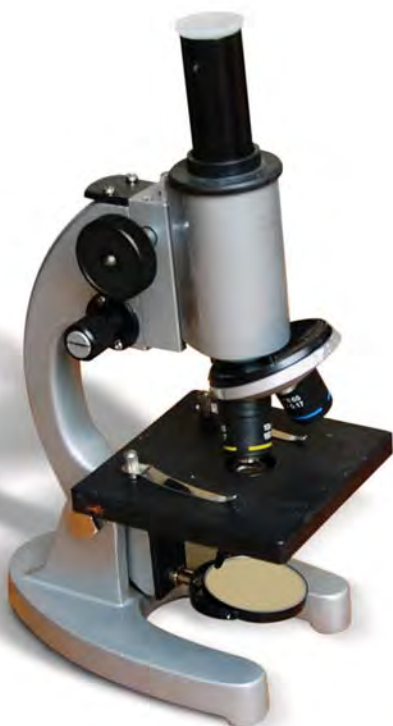

8.1 CROP PRODUCTION AND MANAGEMENT

ACTIVITY 8.1.1

Do plants need manures and fertilisers for better growth?

What is required?

few seedlings of moong/gram or any other commonly occurring plants, 3 small pots with soil, manure and urea .

The substances which are added to the soil in the form of nutrients for the healthy growth of plants are called manures and fertilisers. Soil supplies mineral nutrients to the crops. These nutrients are essential for the growth of plants.

Manure: It is an organic substance obtained from the decomposition of plants and animals wastes. It increases the water holding capacity of the soil. It makes the soil porous and helps in exchange of gases. It improves soil texture and increases the number of helpful microbes in the soil.

Fertilisers: They are chemical substances which are rich in particular nutrients. Fertilisers are produced in factories. Urea, ammonium sulphate, super phosphate and potash are some well known fertilisers which provide the plants with NPK (Nitrogen, Phosphorous, and Potassium). Soil testing is done to find out the nutrients required for the soil

How will you proceed?

1. Select three seedlings of equal size of moong or gram.
2. Take three empty pots and mark them A, B, C.

3. To pot 'A' add a little amount of soil mixed with a little cow dung manure.
4. To pot 'B' put the same amount of soil mixed with few crystals of urea.
5. Take the same amount of soil in pot 'C' without adding anything.
6. Now plant the seedlings in them and pour the same amount of water in each pot.
7. Keep them in a safe open place and water them daily.
8. After 7 to 10 days observe their growth.

What have you learnt?

1. *Plants in all the pots do not show similar growth.*
2. *Plants in pots A and B show faster growth compared to plant in pot C.*
3. *Compare the growth of plants in pots A and B.*
4. *Manures improve the soil texture and water*

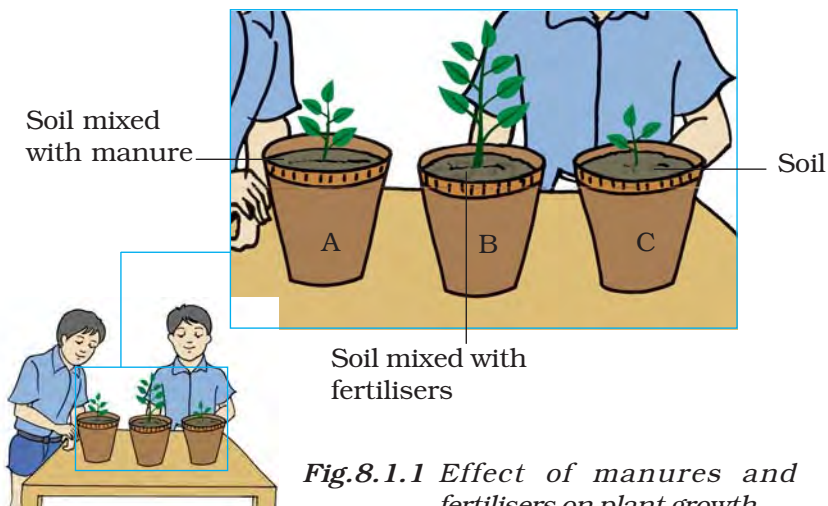

Fig.8.1.1 Effect of manures and fertilisers on plant growth

holding capacity and make the soil well-aerated which facilitates the healthy growth of plants.

Extension

- 1. Ask the farmers which fertilisers they are using for which crops.*
- 2. When do the farmers add manures and fertilisers during agricultural activities and why?*

Notes

8.2 MICROORGANISMS: FRIEND AND FOES

ACTIVITY 8.2.1

*Where do
microorganisms live?*

What is required?

*Beakers, moist soil,
pond water, tap water,
glass slides, droppers,
cover slips, brush,
scalpel and microscope.*

Microorganisms can survive in a wide range of environmental conditions such as soil, water, hot springs, ice cold waters, saline water, deserts, decomposing bodies, etc. and even in volcanic eruptions. They are also present inside the body of animals including humans.

How will you proceed?

1. Collect some moist soil from the field in a beaker.
2. Add water to it and let the soil particles settle down.
3. Take a drop of water from the beaker and place it on a clean glass slide.
4. Put a cover slip over it and observe under the microscope. Are you able to see any moving organisms?
5. Now, prepare another slide in the same way by placing a drop of pond water on it. You can collect water in a beaker from the pond in your locality.

What have you learnt?

The slides show tiny organisms. Does it mean that water and soil are always full of microorganisms?

Do they have any significance?

Fig.8.2.1 (a) Two Algae

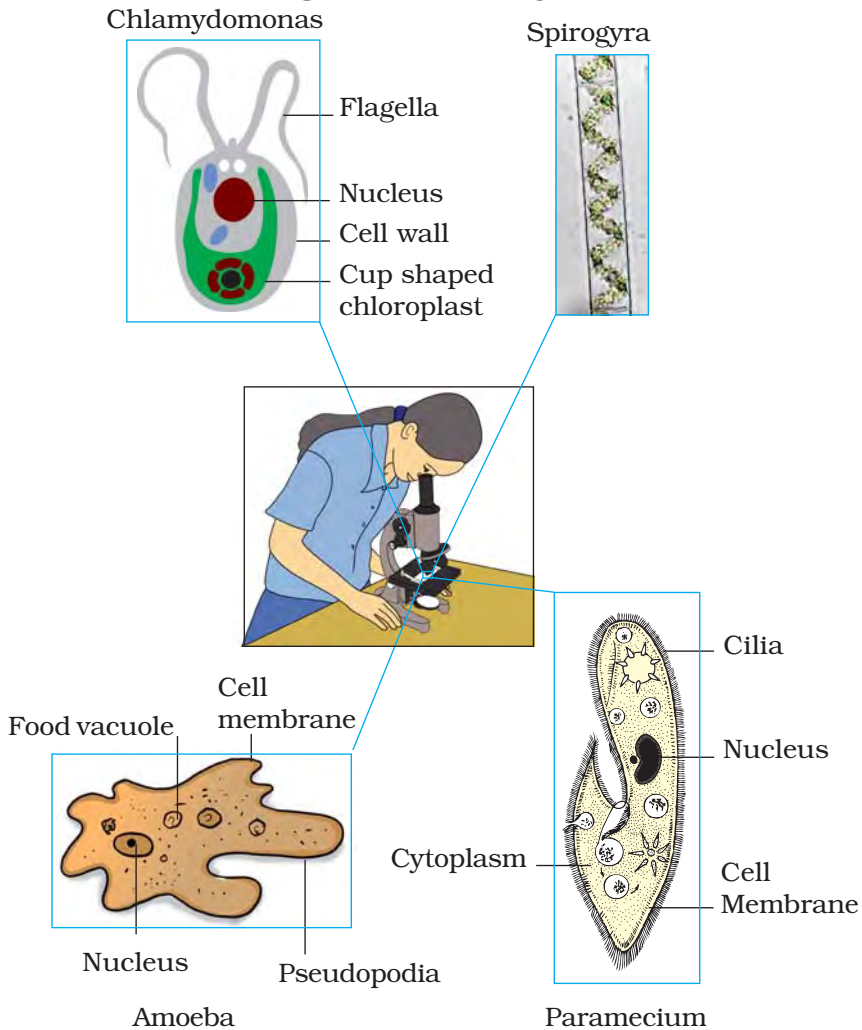

Fig. 8.2.1 (b) Two types of Protozoa

Extension

- 1. Pull out any leguminous plant, such as pea and beans, from the field. Carefully look at the roots of these plants. You will find some nodules. Take one nodule and crush it on a glass slide and stain it with a suitable stain. Observe it under the microscope. Does it show any organisms? What are these? Do they have any significance?*
- 2. Scrap the surface of a leaf or a stone from a pond with the help of a scalpel and place the material thus obtained on a slide. Put a drop of water on it and observe under the microscope. Try to identify the organisms present by comparing them with the figures given in your book.*

ACTIVITY 8.2.2

Are microorganisms an integral part of our life?

What is required?

Stale bread, curd, spoiled food, rotten fruits, petri dish, slides, cover slips and microscope.

How will you proceed?

1. Identify the food items or products at your home which are suspected to contain microorganisms. You can take the help of your teacher.
2. Collect these items.
3. Now, with the help of your teacher, try to find out
 - the type of microorganisms present in each food item.
 - the role played by microorganisms in each of them.
 - whether it is harmful or not?

Tabulate your findings in the table given below (Two examples are already given).

Sl.No.	Food Items	Kind of microorganism	Role and whether beneficial or harmful
1.	Curd	Bacteria (Lactobacillus)	Converts and curdles the milk into curd, beneficial
2.	Spoiled food	Bacteria	Poisoning, harmful
3.			
4.			
5.			

What have you learnt?

Microorganisms play an important role in our lives. Some of them are beneficial and some are harmful.

Extension

- 1. Take some curd and divide it into three parts. Mix one part thoroughly to 250 ml of each of the following: warm milk, boiling milk and cold milk. Observe each mixture after 4 to 6 hours. Note down the observation and try to explain the reasons.*
- 2. Can you tell what happens if you add a little curd to warm milk without mixing it well?*
- 3. Take a slice of bread and cut it into three pieces. Heat one piece till it becomes dry and keep it on a dry plate. Now place the second piece in an airtight container and third in an open and moist plate. Leave them undisturbed for 3 to 4 days. Observe the difference and find out the reasons.*

ACTIVITY 8.2.3

What is the role of microorganisms in fermentation?

What is required?

A test tube, water, sugar, yeast powder, aluminum foil or cotton.

Fermentation is a process of conversion of sugar into alcohol. For this process, microorganisms are used on a large scale in different industries.

How will you proceed?

1. Fill 2/3rd of a test tube with warm water.
2. Add a teaspoon of sugar in it and dissolve.
3. Now put half a spoon of yeast powder to this sugar solution of the test tube. Smell the solution.
4. Thereafter, cover the test tube with aluminium foil or plug its mouth with the cotton.
5. Leave the tube in a warm place for four to five hours.
6. Now uncover the tube and smell the solution.
7. Did you find any difference in the smell of the solution? Can you relate this smell to that of any other item?

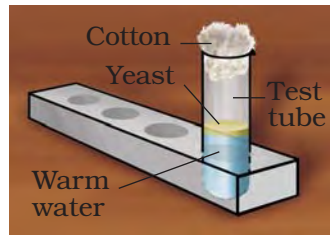

Fig. 8.3.1
Action of yeast on sugar solution

What have you learnt?

After fermentation, the sugar solution smells different.

This smell is due to the action of yeast on sugar solution.

Yeast converts sugar into alcohol and carbon dioxide.

Extension

- 1. Take a plastic bottle and put two teaspoons sugar and half a teaspoon of yeast powder in it. Fill half of bottle with warm water. Now fix the balloon (deflated) onto the mouth of the bottle. Observe after half an hour. Are you surprised to see the result?*
- 2. Take 100 g flour and add some sugar and yeast powder in it. Make soft dough by adding warm water and cover it. Leave it for a few hours in a warm place. Now observe the swollen dough.*

Notes

8.3 SYNTHETIC FIBRES AND PLASTICS

ACTIVITY 8.3.1

Do all threads have the same strength?

What is required?

Iron stand, clamp, cotton thread, weights or marbles, any other available thread, polythene bag.

How will you proceed?

1. Take an iron stand with a clamp.
2. Tie a cotton thread of about 30 cm length so that it hangs freely from the clamp.
3. At the free end of the thread, tie a small polythene bag.
4. Place the weights or marbles gently one by one into the bag, till the thread breaks.

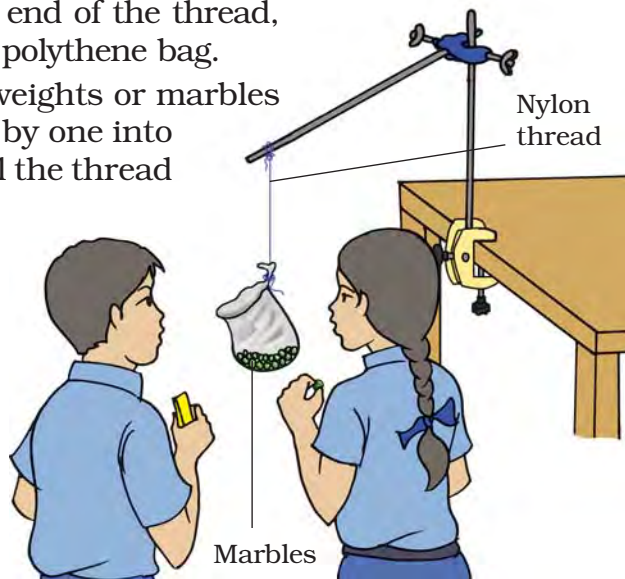

Fig.8.3.1 A thread tied with a small polythene bag hanging from the clamp

- Note the weights, or number of marbles required to break the cotton thread and record it in the table given below.
- Repeat steps 1 to 5 with different types of available threads of same thickness and record your observations in the table given below.

Sl.No.	Types of Thread	Total weight or number of marbles required to break the thread
1.		
2.		
3.		
4.		

What have you learnt?

The weights/number of marbles required to break the thread indicate the strength of the fibre. Which thread/fibre did you observe to be strongest?

Notes

ACTIVITY 8.3.2

Does the synthetic fabric absorb the same amount of water as the natural fabric?

What is required?

*10 cm × 10 cm piece of cotton cloth,
10 cm × 10 cm piece of nylon cloth or
any other synthetic cloth, measuring
cylinder, 2 beakers, water.*

How will you proceed?

1. Take two beakers and fill them with equal amounts of water using a measuring cylinder (else, graduated beakers may be used).
2. Soak the cotton cloth and nylon cloth in these beakers separately for 5 minutes each.
3. Take the cloth pieces out of beakers and spread them in the Sun. Note the time taken by each cloth for drying.

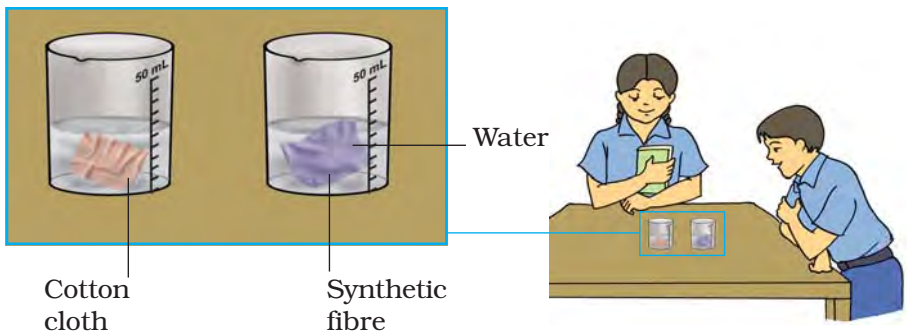

Fig.8.3.2 *Different fibres absorb different amount of water*

4. Note the volume of water that remains in the two beakers using the measuring cylinder
5. Which fabric absorbed more amount of water?
6. Which fabric dried faster?

What have you learnt?

Synthetic fabrics absorb lesser quantity of water as compared to cotton fabric and that is why they dry faster than the cotton fabric.

Extension

1. Try the above activity using polyester, silk, terylene and acrylic cloth.
2. What fabric is used in umbrellas and why?

Notes

8.4 MATERIALS: METALS AND NON-METALS

ACTIVITY 8.4.1

What happens when materials are hammered?

What is required?

Copper wire, coal piece, pencil lead, zinc granules, aluminum wire and hammer.

When materials are hammered, some of them break up into smaller pieces whereas the others spread into the sheets. On this basis, we can classify materials into metals and non-metals. Materials which break up into pieces are non-metals whereas the others which spread into thin sheets are metals.

How will you proceed?

1. Take each of the given materials and beat them with a hammer one by one.
2. What do you observe?

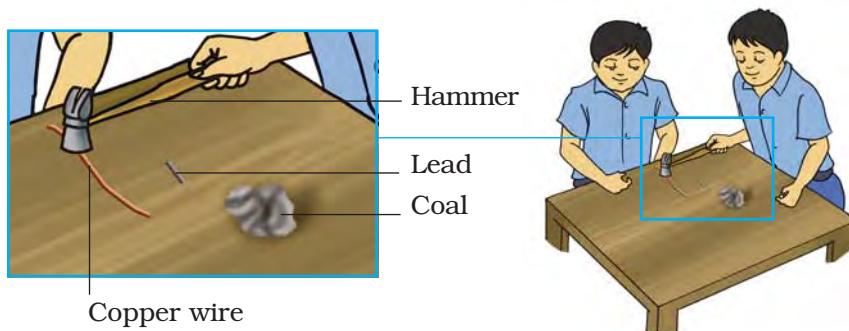

Fig.8.4.1 Beating a piece of wire by a hammer

3. Write your observations in the table given below.

Sl.No.	Object	Observations	Metal / Non-metal
1.	Copper wire	Gets flattened into a strip	Metal
2.	Coal piece		
3.			
4.			
5.			
6.			

What have you learnt?

1. Materials like copper and zinc can be spread into sheets when hammered. Thus, they are metals.

2. Materials like coal and pencil lead break up into pieces when hammered. Thus, they are non-metals.

3. This property of metals by which they can be beaten into thin sheets is known as malleability.

ACTIVITY 8.4.2

Do all materials conduct electricity?

What is required?

Sulphur roll, circuit board assembly, copper strip, iron nail, a piece of coal, aluminum wire.

How will you proceed?

1. Take a circuit board assembly.
2. Place one of the above materials, which are to be tested for conductivity under the tap key.
3. Push the key so that the circuit gets completed.
4. Does the bulb start glowing ?
5. Test the other materials in a similar manner and record your observations in the given table.

Sl.No.	Materials	Good/Poor conductor
1.	Iron nail	
2.		
3.		
4.		
5.		

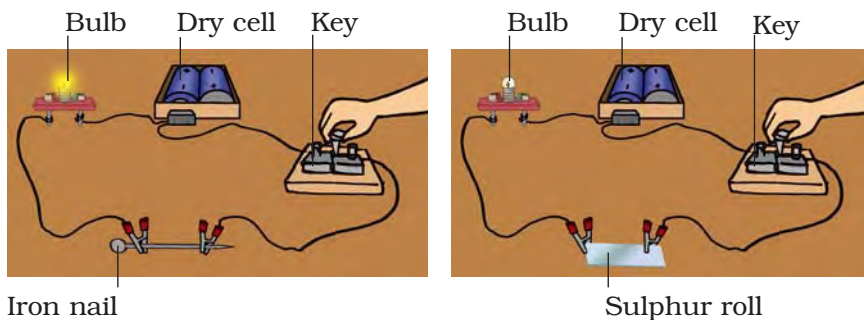

Fig.8.4.2 Testing good conductors and poor conductors

What have you learnt?

- 1. Metals allow the electric current to pass through them and are called conductors. Non-metals do not allow the electric current to pass through them and are called poor conductors.*
- 2. Materials like copper wire and iron nail are good conductors of electricity.*
- 3. Materials like sulphur roll and coal are poor conductors of electricity.*

Notes

ACTIVITY 8.4.3

How will you test whether rust is acidic or basic?

What is required?

Rust, litmus papers (red and blue), test tubes, two watch glasses.

How will you proceed?

1. Take a pinch of rust in a test tube and try to dissolve it in a little amount of water.
2. Has the rust mixed completely with water?
3. Shake the mixture well for sometime.
4. Take few drops of the mixture in two separate watch glasses and test them separately with blue and red litmus papers.
5. Do you find any change in the colours of the litmus papers?
6. Do you find red litmus changing to blue?

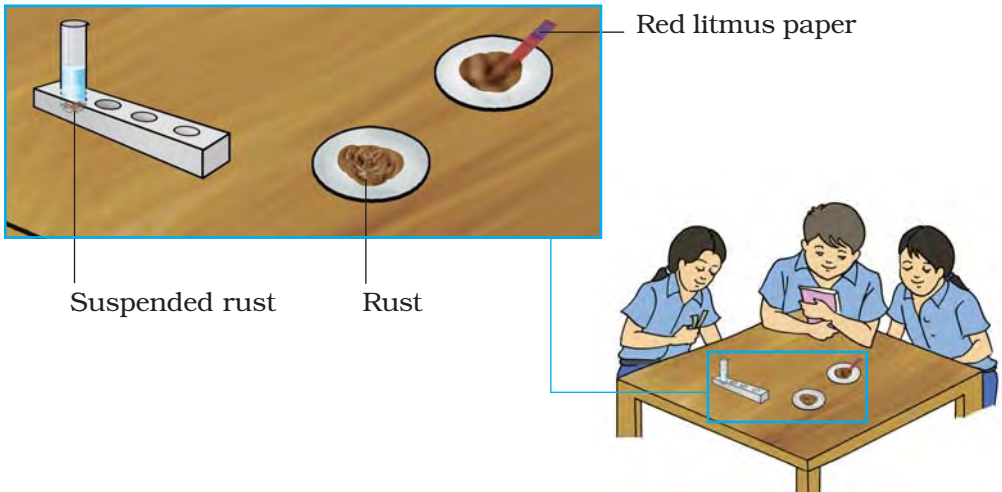

Fig. 8.4.3 To check the acidic or basic nature of rust

What have you learnt?

Rust mixed with water turns red litmus into blue.

Hence, rust is basic. Colour of blue litmus paper does not change.

Extension

Test the nature of dull green coating found on old copper vessels.

Notes

ACTIVITY 8.4.4

How will you test the nature of the gas evolved on burning of sulphur?

What is required?

Sulphur powder, kerosene burner, deflagrating spoon, double mouth flask and rubber cork fitted with water jet, litmus paper strips.

How will you proceed?

1. Take small amount of sulphur powder in the deflagrating spoon.
2. Heat it over a kerosene burner.
3. What do you observe?
4. Name the gas produced.
5. Take a double mouth flask with a water jet fixed on its lower mouth.
6. Place one small piece each of red and blue litmus papers in it and fix it as shown in Fig.8.4.4.

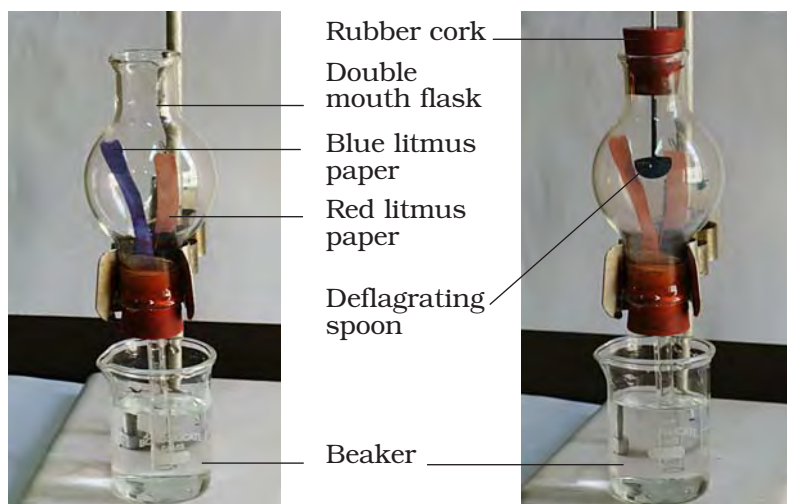

Fig.8.4.4 Burning of sulphur powder

7. Lower the deflagrating spoon with burning sulphur into the flask.
8. Do you see water rushing in through the jet?
9. What may be the possible reason?
10. Did you observe any change in colour in the litmus papers?

What you have learnt?

Sulphur on burning forms sulphur dioxide which is acidic in nature.

Notes

ACTIVITY 8.4.5

To test the nature of solution formed when magnesium reacts with water.

What is required?

Magnesium ribbon, a pair of tongs, beaker, cotton, red and blue litmus papers, kerosene burner.

How will you proceed?

1. Take a small piece of magnesium ribbon.
2. Clean its surface with sand paper.
3. Put it in a test tube and add few mL of water.
4. Put a piece of red litmus paper in it.
5. Heat the test tube over a gentle flame for few minutes.

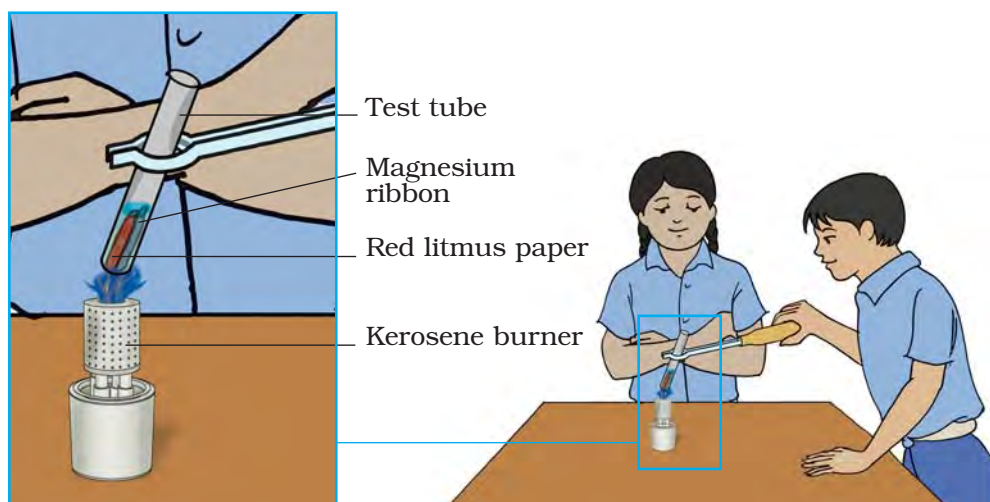

Fig.8.4.5 Determining the nature of solution

6. Do you observe any change in the colour of litmus paper? You would have seen that the litmus paper turns blue.

What have you learnt?

- 1. Magnesium reacts with water to form magnesium hydroxide and hydrogen gas is liberated.*
- 2. Magnesium hydroxide is basic in nature.*
- 3. Thus, Magnesium reacts with water to form a basic solution which turns red litmus to blue.*

Notes

ACTIVITY 8.4.6

What happens when zinc reacts with hot water?

What is required?

Test tubes, small pieces of zinc, red litmus paper, kerosene burner.

How will you proceed?

1. Take a small piece of zinc in a test tube.
2. Add about 2 mL of water to it.
3. Put a piece of red litmus paper into it.
4. Wait for a few minutes.
5. Do you see any change in the colour of the red litmus paper? You would observe that there is no colour change.
6. Heat the test tube on a gentle flame of the kerosene burner for few minutes.

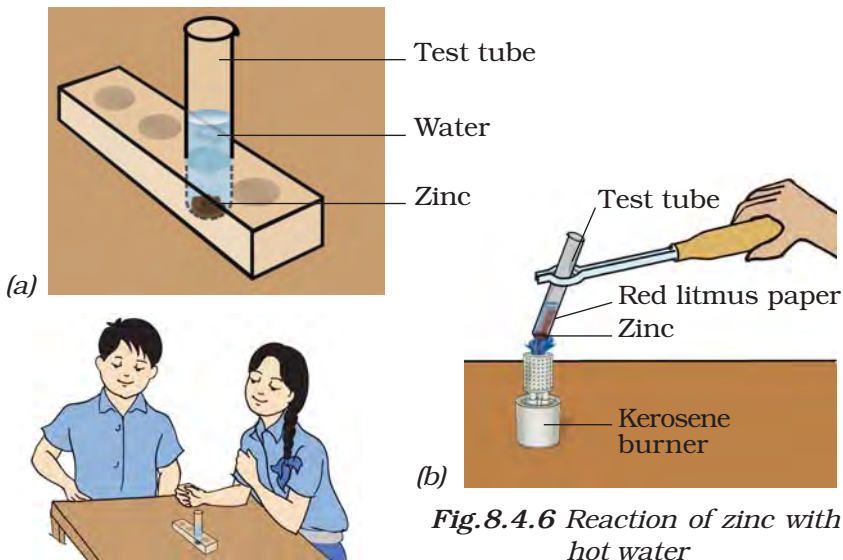

Fig.8.4.6 Reaction of zinc with hot water

7. Is there any change in the colour of the red litmus paper? You would observe that the red litmus paper turns blue.

What have you learnt?

Zinc reacts with water on heating to form a basic solution.

Extension

Repeat this activity using an iron strip.

Notes

ACTIVITY 8.4.7

How do metals and non-metals react with dilute hydrochloric acid?

What is required?

Dilute hydrochloric acid, test tubes, magnesium, aluminium, iron, copper, sulphur powder, charcoal and kerosene burner.

How will you proceed?

1. Take small samples of the above materials in different test tubes and label them as A, B, C, D, E and F.
2. Add few of drops dil. HCl to each test tube.
3. Do you observe reaction taking place in all the test tubes?
4. Heat the test tubes in which there is no reaction in cold.
5. If a reaction takes place, then bring a burning matchstick near the mouth of the test tube.
6. What do you observe?
7. Do you observe that the reaction took place in some of the test tubes and the flame of the match stick goes off with pop sound.

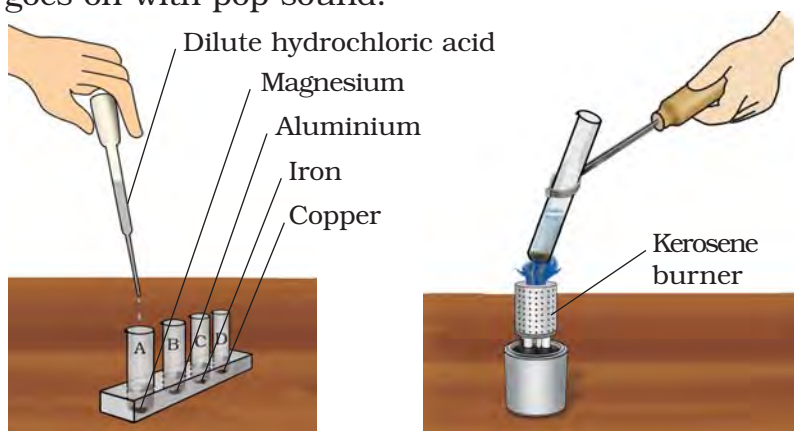

Fig.8.4.7 Reaction of metal and non-metal with dilute hydrochloric acid

- Which gas do you think is coming out during the reaction?
- Repeat the above steps and record your observations for each of the materials in the table given below.

Test tube	Metal/Non-metal	Reaction with dilute hydrochloric acid	
		At room temperature	Warm
A	Magnesium (ribbon)		
B	Aluminium (foil)		
C	Iron (filings)		
D	Copper (wire)		
E	Charcoal (powder)		
F	Sulphur (powder)		

What have you learnt?

- Some metals like magnesium, aluminium and iron react with dil.HCl to produce hydrogen gas whereas less reactive metals like copper and non-metals do not react with dil.HCl.
- Metals like magnesium and aluminium react with dil.HCl at room temperature whereas iron reacts on heating.

Extension

Repeat this activity with dil. H_2SO_4 with the same samples and record your observations in a table.

ACTIVITY 8.4.8

Does aluminum react with a base?

What is required?

Solid sodium hydroxide, test tubes, aluminum foil, kerosene burner.

How will you proceed?

1. Place 3-4 pellets of solid sodium hydroxide in a test tube.
2. Add a small amount of water into it to prepare a solution of sodium hydroxide.
3. Drop a piece of aluminum foil in this solution.
4. Heat the contents on a flame.
5. Do you observe any gas evolving from the test tube?
6. Bring a burning match stick near the mouth of the test tube. Did it go off with a pop sound?

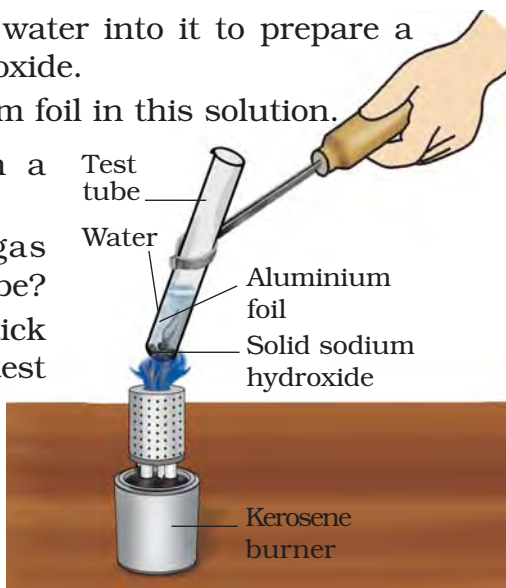

Fig.8.4.8

Reaction of metal and non-metal with dilute hydrochloric acid

What have you learnt?

Aluminum reacts with the base (sodium hydroxide) to form its salt and hydrogen gas is released.

Extension

Repeat this activity with zinc and copper.

ACTIVITY 8.4.9

What happens when metals are immersed in the salt solution of other metals?

A more reactive metal displaces the less reactive metal from its salt solution. No reaction will take place when less reactive metal is immersed in the salt solution of more reactive metal

What is required?

Two beakers, copper sulphate, zinc sulphate, ferrous sulphate, zinc, iron, copper strips.

How will you proceed?

1. Take copper sulphate solution in two beakers.
2. Put an iron strip in one beaker and a zinc strip in the other.
3. Do you observe any change in colour of solution?
4. Do you see any deposit formed on the surface of metal immersed?
5. Repeat the same procedure for
 - (i) copper and iron strips with zinc sulphate solution and
 - (ii) copper and zinc strips with ferrous sulphate solution.
6. Record your observations in the table given below.

<i>Sl.No.</i>	<i>Metal</i>	<i>Salt solution</i>	<i>Change in colour of solution</i>	<i>Deposit formed on surface</i>	<i>Displacement of metal occurs/ does not occur</i>

What have you learnt?

The more reactive metals like zinc or iron displace the less reactive metal like copper.

Extension

- 1. Arrange the above metals in the decreasing order of their reactivity.*
- 2. Which is the most reactive metal?*
- 3. Which is the least reactive metal?*

Notes

8.5 COMBUSTION AND FLAME

ACTIVITY 8.5.1

Are all substances around us combustible?

What is required?

Straw, matchstick, wood, paper, iron nail, stone piece, glass, charcoal, a pair of tongs, a glass rod, kerosene burner.

How will you proceed?

1. Light the kerosene burner.
2. Using a pair of tongs, hold a piece of straw over the flame.
3. What happens to the straw?

When a substance reacts with oxygen to give off heat and, light either as a flame or as a glow, this chemical process, is known as combustion.

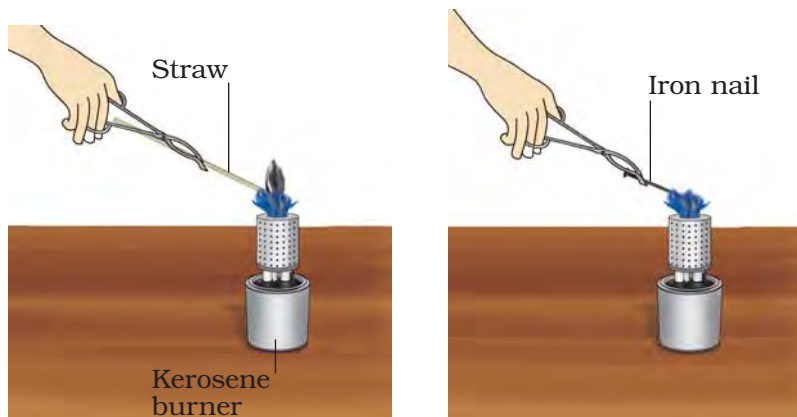

Fig.8.5.1 Distinguishing combustible and non-combustible substances

- Record your observations in the table given below.
- Repeat the above procedure with other materials and record your observations in the table given below.

Sl.No.	Material	Combustible	Non-combustible
1.	Straw		
2.			
3.			
4.			
5.			
6.			

What have you learnt?

1. Substances like wood, paper, straw, etc. burn rapidly in oxygen to give out heat and light and are combustible substances.

2. Substances like stone and glass do not produce heat and light when heated in oxygen and are non-combustible substances.

ACTIVITY 8.5.2

Is air necessary for combustion?

What is required?

Candle, match box, bell jar, two wooden blocks, glass plate.

How will you proceed?

1. Fix a candle on a table and light it.
2. Keep the bell jar over the candle so that it rests on two wooden blocks and air can enter the bell jar.
3. What happens to the flame?
4. Remove the wooden blocks and allow the bell jar to rest on table. Observe the flame of the candle.
5. Now cover the open end of the bell jar with a glass plate. What is the effect on the flame?

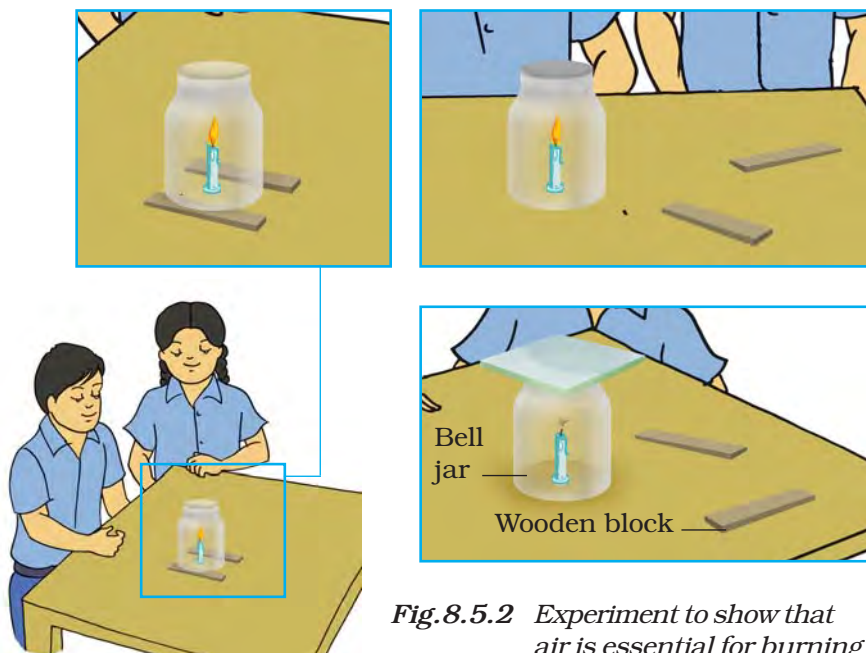

Fig. 8.5.2 Experiment to show that air is essential for burning

What have you learnt?

- 1. The candle burns freely when air can enter the bell jar from below. In this way, hot air escapes from the top and fresh air enters from the bottom.*
- 2. The flame of the candle flickers and produces smoke when sufficient air does not enter into the flask.*
- 3. The flame goes off when the bell jar is covered completely as fresh air is not available.*

Extension

- 1. Take a piece of burning wood or charcoal on an iron plate and cover it with a glass tumbler. Observe what happens to the burning wood or charcoal?*
- 2. Can you now explain why blankets are wrapped around the person, whose clothes catch fire?*

ACTIVITY 8.5.3

Can we heat water in a paper cup over a candle flame without burning it?

What is required?

Two paper cups, candle, match box, water.

How will you proceed?

1. Hold an empty paper cup over a burning candle flame. What happens to the paper cup? (plastic coated paper cup should not be used).
2. Fill the other paper cup with 50 mL water and heat it over the flame. What happens to this paper cup?
3. Do you feel that the water in the cup becomes hot?

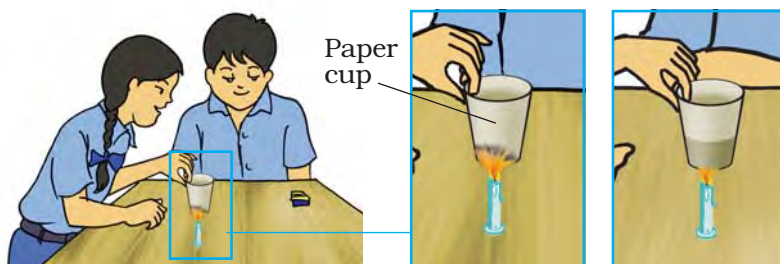

Fig.8.5.3 Heating water in a paper cup

What have you learnt?

1. The water in the paper cup absorbs the heat and the ignition temperature of paper is not reached.
2. Substances burn only if they attain their ignition temperature.

Extension

Try to boil water in a paper cup

ACTIVITY 8.5.4

Is the flame hot throughout?

What is required?

Candle, matchbox, copper tube of approximately 5 cm length and 3 mm diameter, glass slide, pair of tongs, thin copper wire.

How will you proceed?

1. Fix a candle on a stand/table and light it.
2. Hold a copper tube with a pair of tongs and introduce its one end in the innermost part of the flame close to the wick.
3. Bring a lighted match stick near the other end of the copper tube. What do you observe?

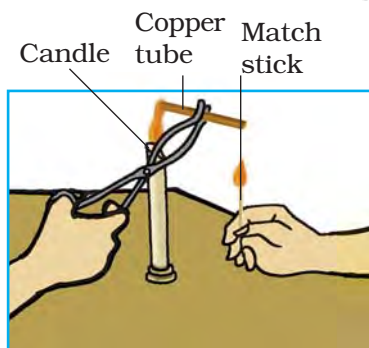
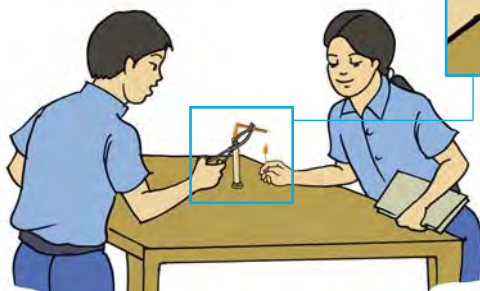

Fig. 8.5.4 Detecting the heat in different parts of the flame



4. When the candle flame is steady, hold a clean glass slide horizontally into the middle zone of the flame for about 10 seconds and remove it. What do you observe on the slide?
5. Now hold a thin copper wire on the outer region of the flame for about 30 seconds. What happens to the wire?

What have you learnt?

- 1. The inner most part of the flame contains unburnt wax vapours which rise into the tube and form flame on the other part of the tube. This part of the flame is the coolest part.*
- 2. The middle region of the flame contains unburnt carbon particles which get deposited on the glass slide. Partial combustion of wax occurs here. This part of the flame has higher temperature than the inner part.*
- 3. The outermost region of the flame is the hottest region. Here the temperature is high enough to heat the copper wire strongly and it starts glowing.*

Extension

- 1. What is the colour of the non-luminous region of the flame?*
- 2. Which zone of the flame is used by goldsmiths for melting of gold and silver?*

8.6 CELL: STRUCTURE AND FUNCTION

ACTIVITY 8.6.1

How to observe Amoeba, Paramecium and yeast under a microscope?

What is required?

Permanent slides of Amoeba, Paramecium and yeast.

Microscope.

Organisms may be unicellular (one celled) or multicellular (many celled). These cells vary in shape and size based on their functions.

How will you proceed?

1. Take a permanent slide of *Amoeba* from the biology laboratory of your school.
2. Study the slide under the microscope. If required, you can adjust the view through the knob present on the microscope.

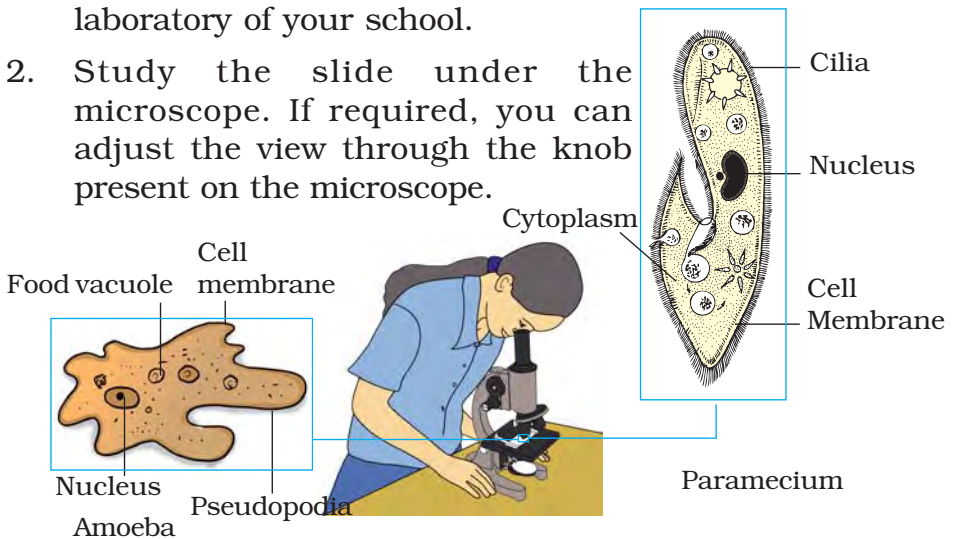

Fig.8.6.1 Observing the permanent slides of Amoeba and Paramecium

3. Now, in a similar way, study the permanent slides of *Paramecium* and yeast.
4. Do they have shape similar to Amoeba? If not, what do they look like?
5. Observe all the slides carefully and draw their sketches in your notebook.

What have you learnt?

Amoeba does not have any definite shape and looks irregular. Whereas, *Paramecium* looks slipper-shaped and has a definite shape. Yeasts, on the other hand, may show some bulges on their body. Do you know what these are? Recall from the activity performed on yeasts in Class VII.

Extension

1. Observe the permanent slides of nerve cell, blood cells and muscle cells. Do they have similar shape or they look different? How do their shapes help them to carry out their functions? Find out.
2. Do you know which part of the cell provides it shape?
3. Try to obtain the information about the kinds of shapes, other than the above, which are found in cells of different organisms.

ACTIVITY 8.6.2

What do plant cells look like?

What is required?

Onion, slides, covers lips, watch glass, safranine solution, forceps, glycerin, needle, brush, microscope, blotting paper and razor blade.

How will you proceed?

1. Take a fleshy leaf of onion bulb.
2. Peel off the skin from the inner side with the forceps.
3. Place the onion skin in watch glass with water.
4. Now add a few drops of safranine.
5. Cut a small piece of the peeled onion skin using a razor blade.
6. Now put a drop of glycerin on a slide and place the piece of the stained peeled onion skin on it. Make sure that the peel is not folded.
7. Gently place a cover slip over the peel using a needle.
8. Clean the edges of the cover slip with a blotting paper.
9. Observe the slide under the microscope.

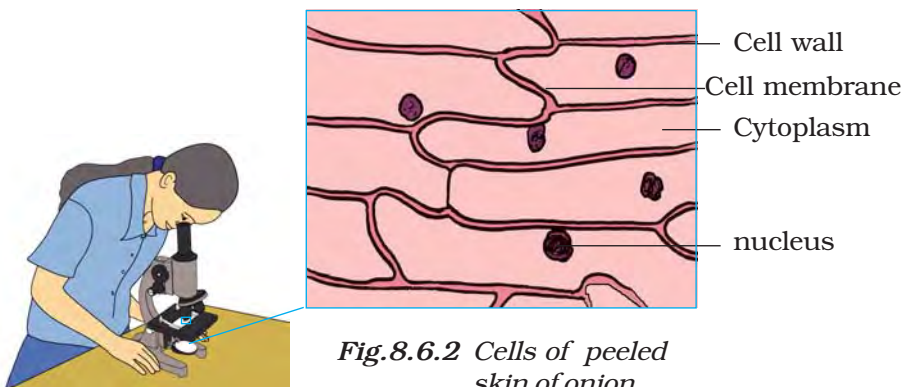

Fig. 8.6.2 Cells of peeled skin of onion

What have you learnt?

Under the microscope you will find, rectangular shaped structures arranged like a brick wall.

You will see that each structure is outlined by a cell wall and cell membrane and there is a distinct dark structure – the nucleus within the **Cytoplasm**.

The small structures which look alike are the basic building blocks of the onion. These structures are called cells. All other organisms are also made up of cells. The major difference between a plant cell and an animal cell is the presence of cell wall in the plant cell.

Extension

You can take a fleshy leaf of other plants and take out their peel to observe the cells. To observe animal cells you can make cheek cell preparation. For this scrap your cheek gently with a tooth pick and place it on a slide. Stain the material with methylene blue.

Place a cover slip and then observe under microscope.

8.7 REPRODUCTION IN ANIMALS

ACTIVITY 8.7.1

How does asexual reproduction occur in small animals such as Hydra and Amoeba?

How will you proceed?

1. Take permanent slide of *Hydra* showing budding and observe under the microscope.
2. Did you observe any bulges coming out from the parent body? What are these?
3. Now observe the permanent slide of *Amoeba* under the microscope.
4. Are you able to see the division of parent cell into two parts?
5. Draw the diagrams in your notebook and label them.

What is required?

Permanent slides of Hydra showing budding and Amoeba showing binary fission and compound microscope.

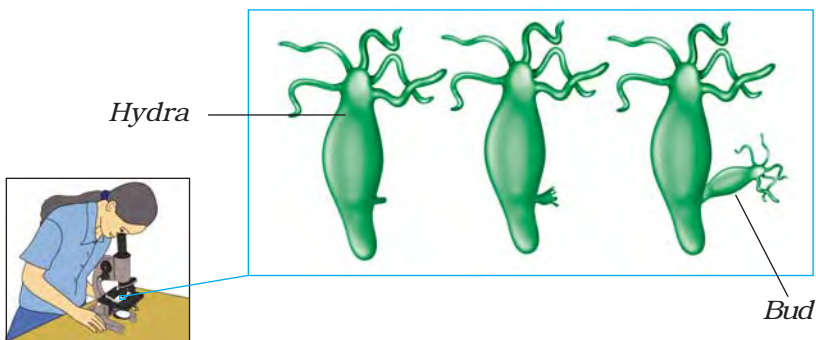

Fig.8.7.1 (a) Budding in hydra

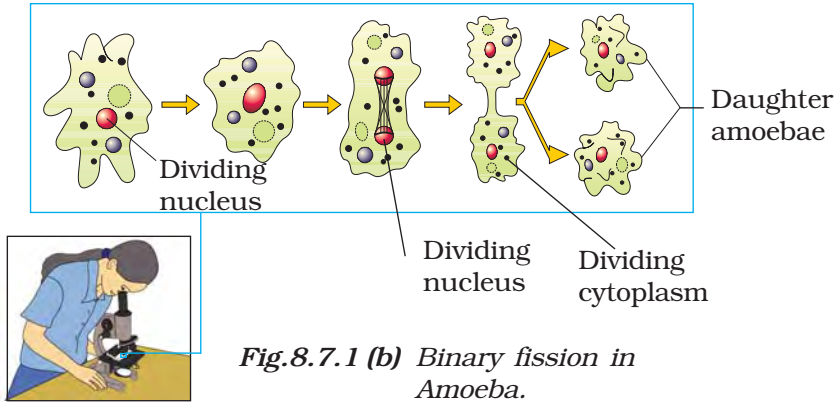

Fig.8.7.1 (b) Binary fission in Amoeba.

What have you learnt?

Hydra and *Amoeba* reproduce asexually by the process of budding and binary fission respectively.

Extension
 Find out other methods of asexual reproduction found in lower animals.

8.8 FORCE AND PRESSURE

ACTIVITY 8.8.1

How can we apply a force on an object without bringing it into physical contact with another object ?

How will you proceed?

A. Force between two bar magnets:

1. Fix a bar magnet on a round disc of thick thermocole sheet with the help of candle wax.
2. Put this thermocole disc in a plastic tub filled with water so that it floats on the surface of water.
3. Now slowly bring the north-pole of another bar magnet near one end of the floating bar magnet and see what happens.
4. Now bring the south-pole of the same bar magnet near the same end of the floating bar magnet and observe what happens now.
5. Repeat steps (3) and (4) using the same or different magnets for few more times and draw conclusion based on your observations.
6. Can you conclude that one magnet exerts force on the other without having any physical contact?

What is required?

A pair of bar magnets, thermocole piece, candle, match box, comb, two plastic straws, two pencils and a plastic tub.

Are these forces attractive or repulsive or both attractive and repulsive?

B. Force between two charged straws:

1. Now take two plastic straws.
2. Rub a plastic straw with a sheet of paper and put the charged straw over two pencils lying on the table as shown in Fig.8.8.1.
3. Now rub another straw with a piece of paper and bring it near the first straw (Make sure that two straws do not touch each other) and observe what happens.
4. Repeat this activity at least two more times. Draw conclusion based on your observations.

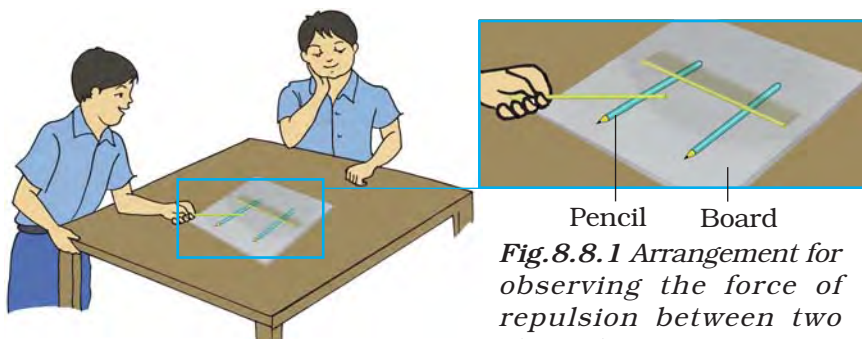

Fig.8.8.1 Arrangement for observing the force of repulsion between two charged straws

What have you learnt?

Objects experience magnetic or electrostatic forces without being brought into physical contact.

Extension

Observe the objects falling freely towards the ground. Is there any force acting on the falling objects? If yes, what type of force is it? Is it a contact force or a non-contact force?

ACTIVITY 8.8.2

How can we show that force acting on a smaller area exerts larger pressure?

How will you proceed?

1. Fill the tray with sand.
2. Fix four pointed nails at the four corners of a wooden hard board piece in such a manner that about half length of every nail remains out equally on either side. Ensure that all the pointed ends of the nails remain on the same side of the hard board.
3. Keep this arrangement gently in the sand filled tray and put gently a body of about 500 g on the hardboard (Fig. 8.8.2).

What is required?

A piece of hard wooden board (8 cm × 8 cm), four identical nails (each 10 cm long), a body of about 500 g, sand and a plastic tray (15 cm × 15 cm).

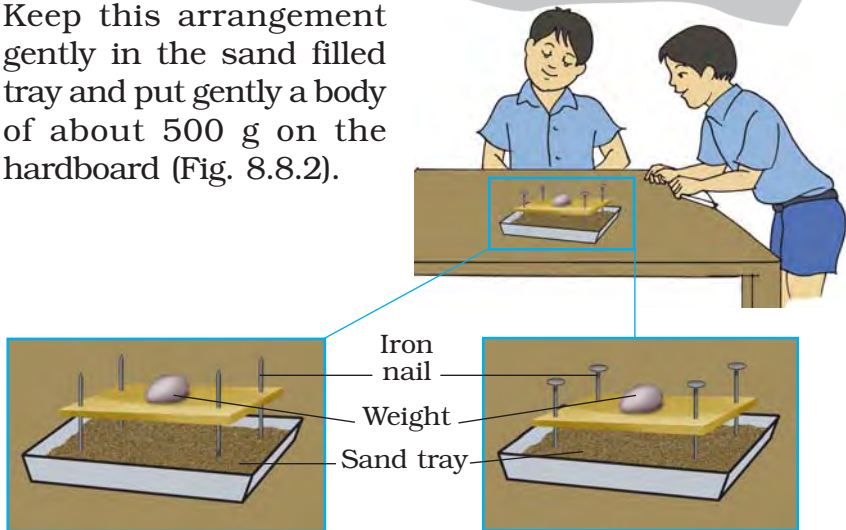

Fig 8.8.2 Arrangement to show the force acting on different area

4. Observe the penetration of the nails of the board in the sand.
5. Now reverse the side of the wooden hardboard and again put the same body of 500 g on the hard board.
6. Observe the penetration of the nails of the board in the sand again.
7. In which case do you find more penetration?
8. Repeat this activity for few more times and draw conclusion based on your observations.

What have you learnt?

Same force exerts more pressure when it acts on a smaller area.

Extension

Repeat the above activity with a brick and a bed of sand on which different faces of the brick are kept separately. In each case also apply impact of a small hammer from a height of about 25 cm. In which case do you find the penetration of brick in sand is more and in which case less?

8.9 FRICTION

ACTIVITY 8.9.1

How can you measure the weight of a given object using a spring balance?

Spring balance is a device used for measuring the force acting on an object. It determines the weight of an object as an attractive force exerted by the earth on the object.

What is required?

*spring balance (scales in g and N),
G-clamp, a small wooden block or a small stone,
and a piece of thread.*

How will you proceed?

1. Hold the spring balance vertically and observe its scale carefully.
2. If the pointer of spring balance is not at the zero mark, then adjust it at zero.
3. Note any two long successive markings on the scale of the spring balance.
4. Note down the number of small divisions in between these two long successive markings.
5. Divide the value between these two long successive markings by the number of divisions between the two. This is the value of one small division of the scale of the spring balance.
6. Now with the help of a thread, suspend the given wooden block from the hook of the spring balance vertically.

7. Observe the position of the pointer on the Newton scale of the spring balance and note its reading.
8. This is the weight of the given wooden block.

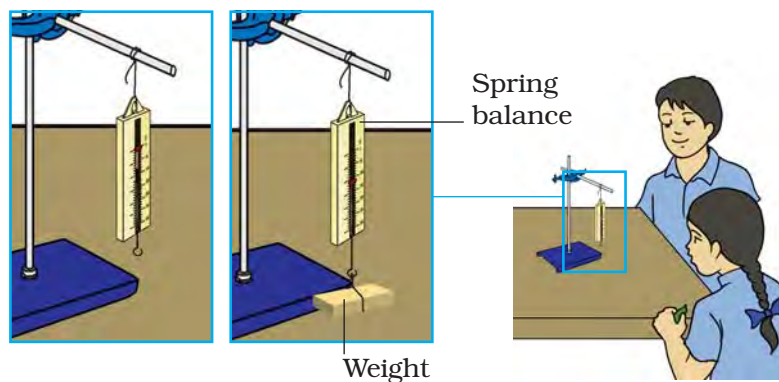

Fig.8.9.1 Measuring the weight of an object using a spring balance

What have you learnt?

One can use a spring balance to measure the weight of an object.

Extension

A spring balance basically measures the weight of the object attached to it. However, the spring balances usually available in the market are often calibrated in the units of mass (g/kg).

Such balances show the ratio of the weight of an object to the acceleration due to gravity at the place of manufacture of the spring balance.

The meaning of the acceleration due to gravity will be discussed in detail in Class IX.

ACTIVITY 8.9.2

How can you show that friction depends upon the nature of the two surfaces in contact?

How will you proceed?

1. Attach the wooden block to the hook of the spring balance.
2. Spread the sand paper sheet on the table and place the wooden block on it.
3. Try to pull the wooden block horizontally on the sand paper sheet first by applying a small force on the spring balance.
4. What do you observe?
5. Now increase the force gradually on the spring balance till the block starts sliding.
6. Note the position of the pointer of the spring balance, when the block just starts sliding.

What is required?

Sunmica sheet, a sand paper sheet and a glass sheet (each of size 50 cm x 15 cm), a spring balance (scales in G and N), wooden block with a hook.

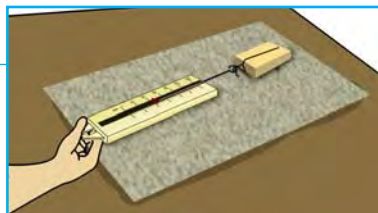
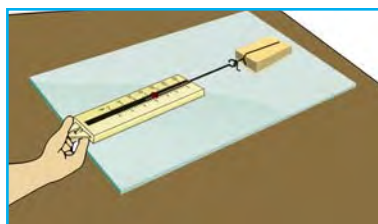
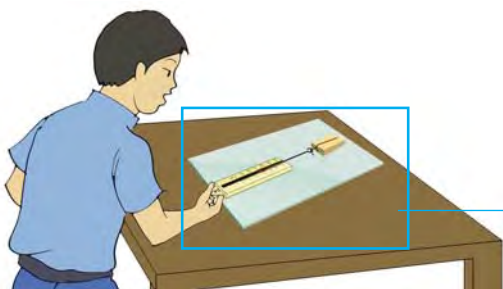

Fig.8.9.2 Friction between two surfaces

7. Now repeat the steps No.5 and 6 first with sunmica sheet and then with glass sheet in place of sand paper.
8. In which case you require more force to slide the block?
9. In which case you require less force to slide the block?
10. Draw conclusion based on your observations.

What have you learnt?

Friction depends upon the nature of the surfaces in contact. For smooth surfaces, friction is less. For rough surfaces, friction is more.

Extension

Repeat this activity by wrapping the wooden block first with a sheet of paper and then with a polythene sheet. Slide the wooden block every time on the surface of the same sunmica sheet and compare the results.

8.10 SOUND

ACTIVITY 8.10.1

How can we distinguish between a pleasant sound and a noise?

What is required?

Four to six glass tumblers (or bowls) of same size, a metal rod, a pencil, water and one metallic tumbler (bowl).

How will you proceed?

1. Place 4 to 6 glass tumblers (or bowls) keeping separation among them.
2. Fill the tumblers (or bowls) with water to different levels.
3. Now strike the tumblers (or bowls) one by one with a pencil repeatedly (Fig 8.10.1) and feel the sound produced by each tumbler (or bowl). What do you observe?
4. What can you say about the sound produced by each tumbler (or bowl) in Step 3. Is the sound produced pleasant?
5. Now strike the metallic tumbler (or bowl) vigorously using a metal rod.
6. Is the sound produced pleasant even now?



Glasses **Fig. 8.10.1**
A typical jaltarang producing pleasant sound

What have you learnt?

Some sounds are pleasant and some are not pleasant.

ACTIVITY 8.10.2

How can you show that sound can travel through a string?

What is required?

A string (about 10 m long), two paper cups or plastic cups or empty ice cream cups.

How will you proceed?

1. Make a small hole at the bottom of each cup.
2. Tie a string between them by making knots.
3. Stretch the string between the two cups.
4. Use one cup as receiver and other as mouth piece.
5. Now keeping the string sufficiently stretched ask your friend to speak from the mouth piece.
6. Try to hear the voice of your friend through the receiver. Can you hear it clearly [Fig. 8.10.2]?
7. If you are able to hear the sound of your friend through the receiver then sound has travelled from the mouth of your friend to your ear through the string only.
8. Try to draw conclusions from this activity.

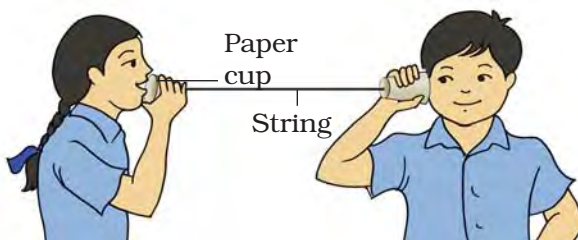

Fig. 8.10.2 Sound travels through the string

What have you learnt?

Sound can travel through a string.

ACTIVITY 8.10.3

How can we produce waves using a slinky?

What is required?

A slinky.

How will you proceed?

1. Hold one end of a slinky lying on a floor.
2. Ask your friend to sit at a distance holding the other end of the slinky.
3. Let him hold the slinky steadily. Now give lateral (side way) jerks to the slinky continuously and observe the pattern of the disturbances (waves) produced in it.
4. Increase the frequency of the jerks and observe the pattern.
5. Now give larger jerks to the slinky and observe the disturbance that occurs in the slinky from its original position.
6. When do you see larger disturbance in the slinky?
7. When do you see smaller disturbance?
8. Now let the slinky come to rest and ask your friend to hold it.
9. Give the slinky a jerk along its length and observe the pattern of the disturbance produced in it.
10. Now give this kind of jerks continuously to the slinky and observe the pattern of the wave produced in it.
11. Draw conclusion based on this activity.

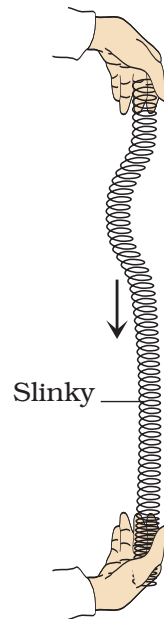

Fig.8.10.3
A slinky

What have you learnt?

Different types of waves can be produced in a slinky.

Extension

Repeat the above activity using a string.

Can we produce similar type of waves in the string as observed above in the case of slinky?

Notes

8.11 CHEMICAL EFFECTS OF ELECTRIC CURRENT

ACTIVITY 8.11.1

How can you show that water can be splitted into its constituent elements?

Passage of electric current through many substances in molten state causes their decomposition. This process is called electrolysis. Electrolysis of water can be carried out in laboratory where water decomposes into its constituent elements, namely; hydrogen and oxygen.

What is required?

Bell jar, rubber cork with two stainless steel electrodes, water, 6 V battery (four dry cells of 1.5 V each in a cell holder), plug key, connecting wires, glass rod, universal indicator, sodium sulphate, dropper.

How will you proceed?

1. Take water in a 50 mL beaker.
2. Add sodium sulphate to water and stir well to prepare its concentrated solution.
3. Add universal indicator drop by drop till colour of the solution becomes dark green.
4. Take two plastic graduated droppers of 3 mL capacity and cut their lower ends. Fill the remaining 3 cm of its length stem completely with sodium sulphate solution.

5. Fix the rubber cork with two stainless steel electrodes in the bell jar and clamp it in the inverted position as shown in Fig. 8.11.1.
6. Fill the bell jar with the remaining coloured solution.
7. Lower the droppers filled with coloured solution over two steel electrodes carefully.
8. Connect a 6 V battery to the 2 electrodes with connecting wires.
9. Also insert a plug key in the circuit and keep the key open.
10. Now close the key and observe the two electrodes carefully. What do you notice?
11. Do you observe any bubbles forming on the two electrodes?
12. Do you notice any colour change in the two droppers?
13. Find out the reason of the colour change.



Fig.8.11.1 Water splitted into its components

What have you learnt?

When an electric current passes through it, water splits into two gases-hydrogen and oxygen.

Extension

Repeat the activity with distilled water without adding any salt and note down your observations.

ACTIVITY 8.11.2

How can you use electric current for coating a metal over the surface of another metal?

What is required?

Six Volt battery (four 1.5 V dry cells in a cell holder), 50 mL beaker, copper sulphate crystals, dil. sulphuric acid, connecting wires having crocodile clips at the two ends, 2 copper plates of size (about 5 cm × 2 cm), sand paper and plug key.

How will you proceed?

1. Prepare fresh copper sulphate solution by dissolving one teaspoonful of copper sulphate in water taken in a 50 mL beaker.
2. Add about 10-12 drops of dil. sulphuric acid to this solution.
3. Clean the copper plates with sand paper and rinse them with water.
4. Connect the two copper plates to the +ve and -ve terminals of a battery using separate connecting wires fitted with crocodile clips.
5. Now immerse the two electrodes (i.e. copper plates) in copper sulphate solution keeping them at a distance. Take care that the 2 plates do not touch each other [Fig.8.11.2].
6. Allow the passage of current through the solution by closing the plug key. Wait for about 20 minutes.
7. Now open the key and remove the plates from the solution and observe them carefully. Do the plates look alike?
8. Do you find some coating on any of the plates?

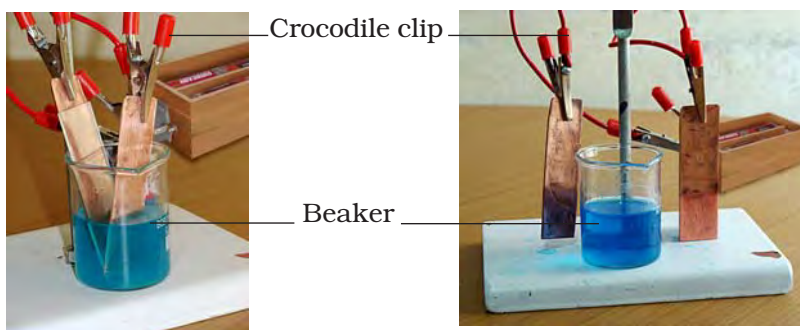

Fig.8.11.2 A simple electric circuit showing electroplating

Note the colour of the coating and also the terminal to which it is connected.

What have you learnt?

*When an electric current is passed through copper sulphate solution the copper sulphate dissociates and copper from the solution goes to the plate connected to the negative terminal of the battery (cathode). To compensate for this loss of copper the same amount of copper from the anode goes to the solution. Thus copper from the plate connected to the positive terminal gets deposited on the plate connected to the negative terminal. The process of depositing a layer of desired metal on another material using electricity is called **electroplating**.*

Extension

- 1. Chrome plated handles of bicycles are very popular these days. How are they made?*
- 2. At times ornaments which appear to be made of gold are available at cheaper rates in some shops. How it happens?*

8.12 SOME NATURAL PHENOMENA

ACTIVITY 8.12.1

How is an electroscope made?

What is required?

Bell jar, J-shaped metal wire passing through rubber cork and having metallic disc fitted at the other end, comb, aluminium foil, a pair of scissors, plastic strip with wollen cloth.

How will you proceed?

1. Cut a rectangular piece of aluminium foil of size about 10 mm × 10 mm and fold it in V-shape .
2. Hang the V-shaped aluminium foil at the lower end of the J-shaped wire fitted into the bell jar as shown in Fig.8.12.1. Your electroscope is now ready.
3. Rub a comb with dry hair or plastic strip with wollen cloth.
4. First bring the rubbed comb near to the disc of the electroscope and then touch it.

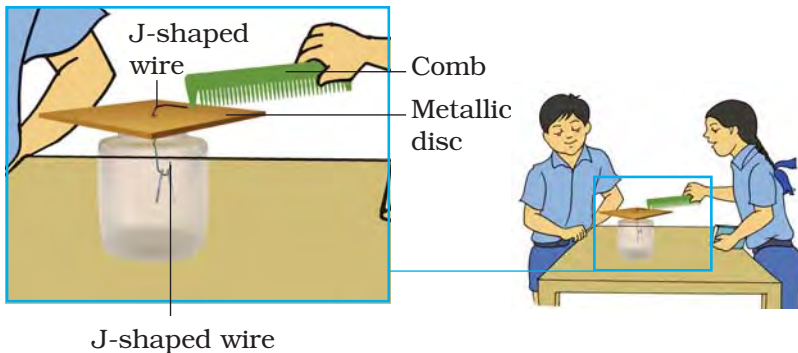

Fig.8.12.1 An electroscope

5. Observe the shape of the aluminium foil. Do you notice any change? The tips of the two leaves of the aluminum foil spread out.
6. Find the reason of this spread.

What have you learnt?

similar charges are acquired by the two leaves of the aluminium foil and they spread out.

Notes

ACTIVITY 8.12.2

Do charges interact with each other?

What is required?

Two balloons, thread, G-clamp, two used ball point pen refills, beaker, woollen cloth and polyster cloth.

How will you proceed?

1. Inflate two balloons.
2. Hang them in such a way that they are at the same height but do not touch each other.
3. Rub both the balloons with a woollen cloth and then release.
4. What do you observe?
5. Why do they move away from each other?
6. Repeat the above activity:
 - (i) by taking two used ball pen refills in place of two balloons and polyester/woollen cloth.

Place one used refill after rubbing with polyester/woollen cloth in a beaker and bring the other one near it after rubbing.

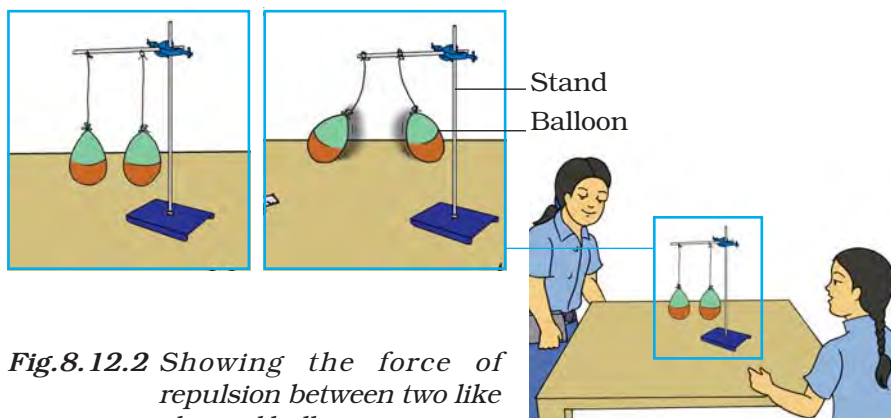

Fig.8.12.2 Showing the force of repulsion between two like charged balloons

(ii) by taking one balloon and one refill.

What difference do you notice in the above two cases and why? You may observe the following:

In activity (i) two refills will be seen to repel each other.

In activity (ii) balloon and refill will be seen to attract each other.

7. Draw conclusions based on the above activities.

What have you learnt?

Like charges repel and unlike charges attract each other.

Extension

Perform the above activity using two small thermocol balls after suspending them from a support.

Notes

8.13 LIGHT

ACTIVITY 8.13.1

How can you verify laws of reflection of light using a plane mirror?

What is required?

Generator, ray streak apparatus, plane mirror, connecting wires with crocodile clips, white sheet of paper and sharp pencil.

How will you proceed?

1. Close all the slits of the ray streak apparatus except one of it and place the apparatus on a white sheet of paper.
2. Connect the bulb of ray streak apparatus with the terminals of the generator.
3. Rotate the handle of the generator and observe the ray of light obtained on the sheet of paper.
4. Now place a plane mirror in the path of this ray of light.
5. What happens to the direction of ray of light after reflection from the mirror ?
6. Using a sharp pencil draw the positions of the plane mirror, the incident ray and the reflected ray.
7. Repeat this activity for the rays incident at different angles on the plane mirror by rotating the mirror.
8. Draw normals at the point of incidence in each case.
9. Measure the angle of incidence and the angle of reflection in each case and note down their values in the tabular form.

10. What relationship do you notice between the angles.
11. Now take a sheet of stiff paper or a thin sheet of white paper. Let the sheet of stiff paper project a little beyond the table.
12. Cut the projected portion of the paper sheet at the middle.
13. Repeat the activity given above.
14. Make adjustment in such a way that the reflected ray lies on the projected portion of the sheet of paper.
15. Now bend the projected portion of paper, on which the reflected ray falls downwards and observe what happens.
16. Do you still get reflected ray on the bent portion of the paper? If not, what conclusion can you draw from this observation?

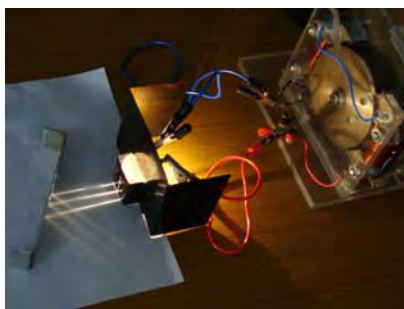

Fig.8.13.1 Reflection of light by a plane mirror

What have you learnt?

1. Angle of incidence is equal to the angle of reflection.

2. Incident ray, reflected ray and the normal to the reflecting surface at the point of incidence, all lie in the same plane.

ACTIVITY 8.13.2

How can you show that a reflected light can be further reflected?

What is required?

Two plane mirrors of size about 15 cm X 20 cm and a chair.

How will you proceed?

1. Sit on a chair with a window behind you.
2. Are you able to see the objects outside the window? Certainly not.
3. Now take two plane mirrors.
4. Hold one of the mirrors in your right hand and the other in your left hand.
5. Now adjust the two mirrors in such a way that you can see the objects outside the window in the mirror, as shown in the Fig.8.13.2.
6. Try to find, “How do the rays from the objects behind you travel to your eyes?”
7. If possible, try to trace the path of light from the objects to your eyes.

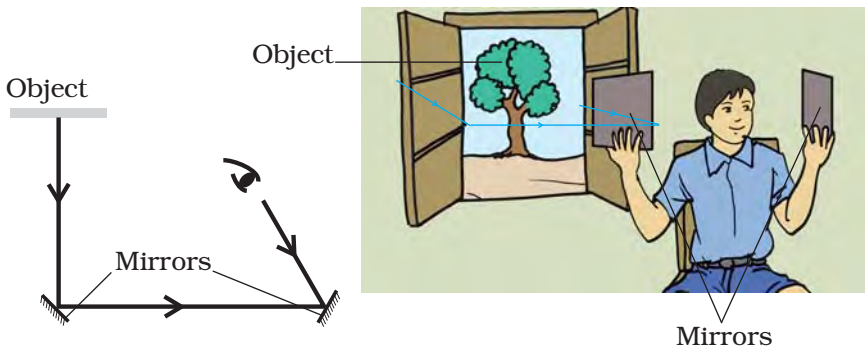

Fig.8.13.2 Reflection of light

What have you learnt?

Light can undergo multiple reflections.

ACTIVITY 8.13.3

How can you make your own kaleidoscope?

What is required?

Three rectangular plane mirror strips of equal size, rubber bands, bangle pieces, two triangular glass pieces, card sheet and cellotape.

How will you proceed?

1. Take three rectangular plane mirror strips and join them in a triangular shape with cellotape such that their polished surfaces are on the inside and inclined at an angle of 60° with respect to each other as shown in Fig. 8.13.3.
2. Slip the rubber bands on the triangular tube, so formed, at different positions such that the mirror strips remain in place. Fix this triangular tube in a cylindrical tube made of card sheet. Ensure that this tube is slightly longer than the triangular tube.

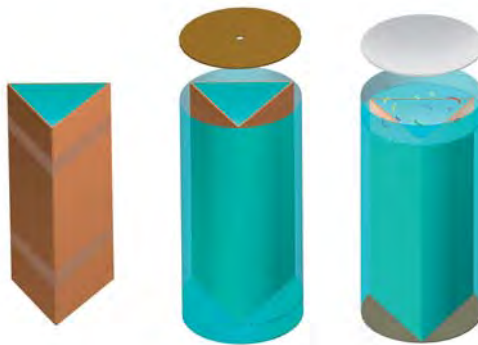

Fig.8.13.3 Arrangement for making a kaleidoscope

3. Take two triangular glass plates of such dimensions as to fit at one end of the tube. Cover one glass plate with tracing paper .
4. Place one of the triangular glass plate at one end of the tube such that it is a little inside the tube.
5. Now place some multi-coloured bangle pieces over it.
6. Cover this end of the tube with another triangular glass plate covered with tracing paper.
7. Cover the other end of the tube with a piece of card sheet and make a hole in the centre so that the inside view can be seen through this hole. The kaleidoscope is ready.
8. Peep through the hole directing the other end of the tube towards light.
9. What do you observe?
10. Now rotate the tube a little and observe. Do you get the same pattern now? Why do we see different coloured patterns every time?
11. What do you infer from these observations?

What have you learnt?

We see different coloured patterns in a kaleidoscope due to multiple reflections of light.

ACTIVITY 8.13.4

How can you show that the sunlight can be splitted into different seven colours?

What is required?

A triangular glass prism and a white screen.

How will you proceed?

1. Hold the glass prism such that one of its faces is towards the sunlight while the other is towards a white screen (white wall or white sheet of paper).
2. Adjust the prism such that violet, indigo, blue, green, yellow, orange and red light is seen on the white screen.
3. What does this indicate?

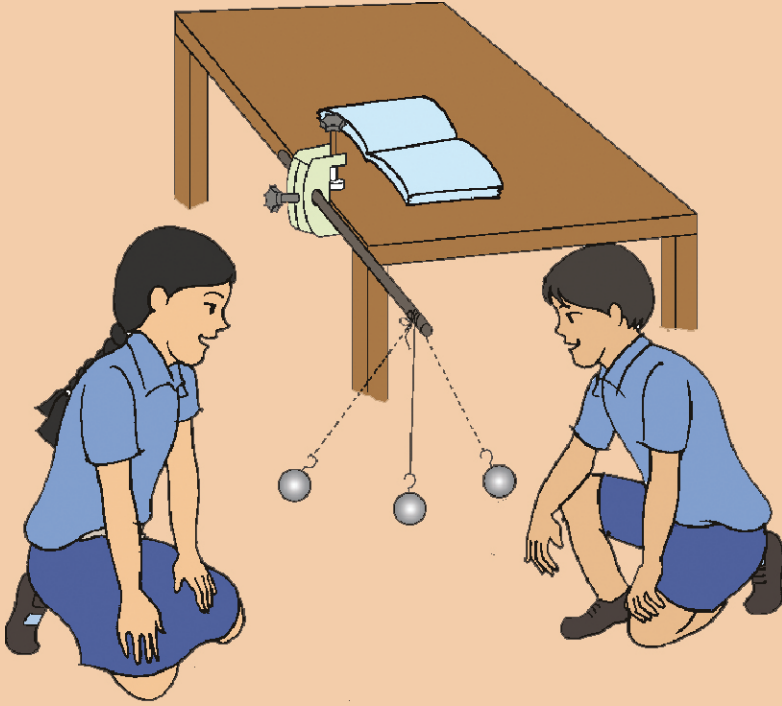

Fig.8.13.4 Sunlight splitting into seven constituent colours

What have you learnt?

White light is splitted into seven constituent colours when passed through a glass prism.

Notes



1335

विद्यया ऽ मृतमश्नुते



एन सी ई आर टी
NCERT

राष्ट्रीय शैक्षिक अनुसंधान और प्रशिक्षण परिषद्
NATIONAL COUNCIL OF EDUCATIONAL RESEARCH AND TRAINING

ISBN 978-93-5007-050-5

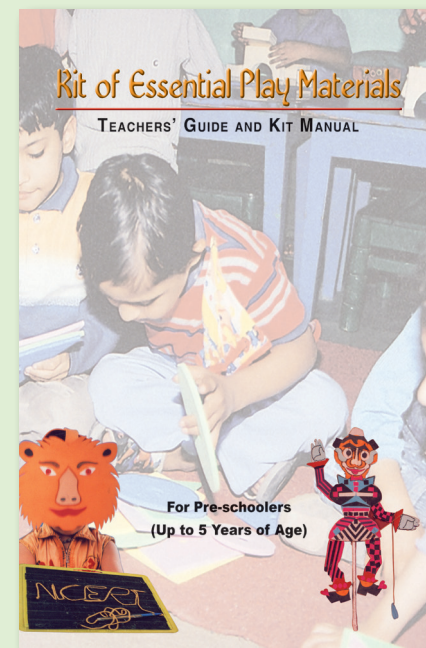
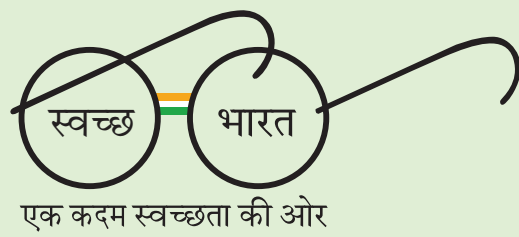

₹ 85.00/pp.82
Code — 1563
ISBN — 81-7450-699-3



₹ 290.00/pp.188
Code — 13073
ISBN — 978-93-5007-176-2

For further enquiries, please visit www.ncert.nic.in or contact the Business Managers at the addresses of the regional centres given on the copyright page.