

# EXPERIMENT 14

## AIM

To study the relationship between the temperature of a hot body and time by plotting a cooling curve.

## APPARATUS AND MATERIAL REQUIRED

Newton's law of cooling apparatus that includes a copper calorimeter with a wooden lid having two holes for inserting a thermometer and a stirrer and an open double-walled vessel, two celsius thermometers (each with least count  $0.5^\circ\text{C}$  or  $0.1^\circ\text{C}$ ), a stop clock/watch, a heater/burner, liquid (water), a clamp stand, two rubber stoppers with holes, strong cotton thread and a beaker.

## DESCRIPTION OF APPARATUS

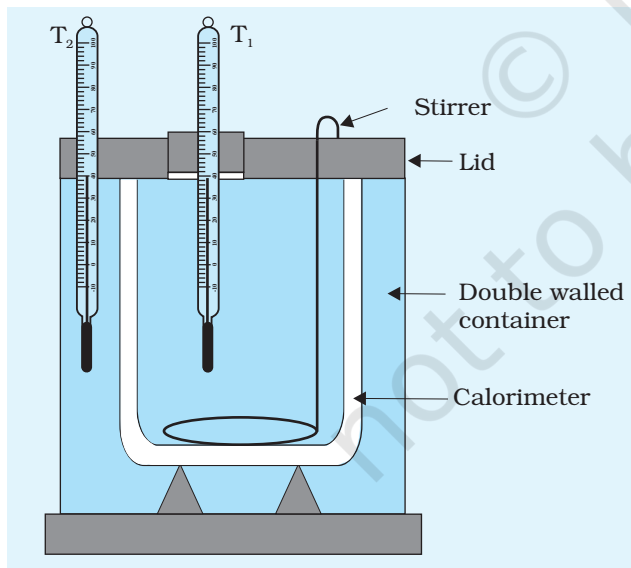

**Fig.E 14.1:** Newton's law of cooling apparatus

As shown in Fig. E 14.1, the law of cooling apparatus has a double walled container, which can be closed by an insulating lid. Water filled between double walls ensures that the temperature of the environment surrounding the calorimeter remains constant. Temperature of the liquid and the calorimeter also remains constant for a fairly long period of time so that temperature measurement is feasible. Temperature of water in calorimeter and that of water between double walls of container is recorded by two thermometers.

## THEORY

The rate at which a hot body loses heat is directly proportional to the difference between the temperature of the hot body and that of its surroundings and depends on the nature of material and the surface area of the body. This is

Newton's law of cooling.

For a body of mass  $m$  and specific heat  $s$ , at its initial temperature  $\theta$  higher than its surrounding's temperature  $\theta_0$ , the rate of loss of heat

is  $\frac{dQ}{dt}$ , where  $dQ$  is the amount of heat lost by the hot body to its surroundings in a small interval of time.

Following Newton's law of cooling we have

$$\text{Rate of loss of heat, } \frac{dQ}{dt} = -k (\theta - \theta_0) \quad \text{(E 14.1)}$$

$$\text{Also } \frac{dQ}{dt} = ms \frac{d\theta}{dt} \quad \text{(E 14.2)}$$

Using Eqs. (E 14.1) and (E 14.2), the rate of fall of temperature is given by

$$\frac{d\theta}{dt} = -\frac{k}{ms} (\theta - \theta_0) \quad \text{(E 14.3)}$$

where  $k$  is the constant of proportionality and  $k' = k/ms$  is another constant (The term  $ms$  also includes the water equivalent of the calorimeter with which the experiment is performed). Negative sign appears in Eqs. (E 14.2) and (E 14.3) because loss of heat implies temperature decrease. Eq. (E 14.3) may be re written as

$$d\theta = -k' (\theta - \theta_0) dt$$

On integrating, we get

$$\frac{d\theta}{\theta - \theta_0} = -k' dt$$

$$\text{or } \ln (\theta - \theta_0) = \log_e (\theta - \theta_0) = -k't + c$$

$$\text{or } \ln (\theta - \theta_0) = 2.303 \log_{10} (\theta - \theta_0) = -k't + c \quad \text{(E 14.4)}$$

where  $c$  is the constant of integration.

Eq. (E 14.4) shows that the shape of a plot between  $\log_{10} (\theta - \theta_0)$  and  $t$  will be a straight line.

## PROCEDURE

1. Find the least counts of thermometers  $T_1$  and  $T_2$ . Take some water in a beaker and measure its temperature (at room temperature  $\theta_0$ ) with one (say  $T_1$ ) of the thermometers.
2. Examine the working of the stop-watch/clock and find its least count.
3. Pour water into the double-walled container (enclosure) at room temperature. Insert the other thermometer  $T_2$  in water contained in it, with the help of the clamp stand.
4. Heat some water separately to a temperature of about  $40^\circ\text{C}$  above the room temperature  $\theta_0$ . Pour hot water in calorimeter up to its top.

5. Put the calorimeter, with hot water, back in the enclosure and cover it with the lid having holes. Insert the thermometer  $T_1$  and the stirrer in the calorimeter through the holes provided in the lid, as shown in Fig. E14.1.
6. Note the initial temperature of the water between enclosure of double wall with the thermometer  $T_2$ , when the difference of readings of two thermometers  $T_1$  and  $T_2$  is about  $30^\circ\text{C}$ . Note the initial reading of the thermometer  $T_1$ .
7. Keep on stirring the water gently and constantly. Note the reading of thermometer  $T_1$ , first after about every half a minute, then after about one minute and finally after two minutes duration or so.
8. Keep on simultaneously noting the reading of the stop-watch and that of the thermometer  $T_1$ , while stirring water gently and constantly, till the temperature of water in the calorimeter falls to a temperature of about  $5^\circ\text{C}$  above that of the enclosure. Note the temperature of the enclosure, by the thermometer  $T_2$ .
9. Record observations in tabular form. Find the excess of temperature  $(\theta - \theta_0)$  and also  $\log_{10}(\theta - \theta_0)$  for each reading, using logarithmic tables. Record these values in the corresponding columns in the table.
10. Plot a graph between time  $t$ , taken along x-axis and  $\log_{10}(\theta - \theta_0)$  taken along y-axis. Interpret the graph.

## OBSERVATIONS

Least count of both the identical thermometers = ...  $^\circ\text{C}$

Least count of stop-watch/clock = ... s

Initial temperature of water in the enclosure  $\theta_1 = \dots^\circ\text{C}$

Final temperature of water in the enclosure  $\theta_2 = \dots^\circ\text{C}$

Mean temperature of the water in the enclosure  $\theta_0 = (\theta_1 + \theta_2)/2 = \dots^\circ\text{C}$

**Table E 14.1: Measuring the change in temperature of water with time**

S. No.	Time ( $t$ ) (s)	Temperature of hot water $\theta$ $^\circ\text{C}$	Excess Temperature of hot water $(\theta - \theta_0)$ $^\circ\text{C}$	$\log_{10}(\theta - \theta_0)$
1				
2				
.				
.				
20				

## PLOTTING GRAPH

- Plot a graph between  $(\theta - \theta_0)$  and  $t$  as shown in Fig. E 14.2 taking  $t$  along x-axis and  $(\theta - \theta_0)$  along y-axis. This is called cooling curve.
- Also plot a graph between  $\log_{10}(\theta - \theta_0)$  and time  $t$ , as shown in Fig. E 14.3 taking time  $t$  along x-axis and  $\log_{10}(\theta - \theta_0)$  along y-axis. Choose suitable scales on these axes. Identify the shape of the cooling curve and the other graph.

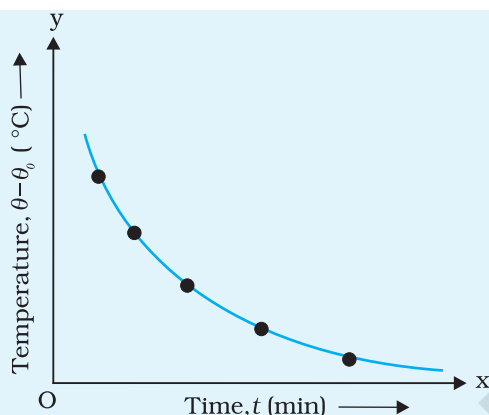

**Fig.E 14.2:** Graph between  $(\theta - \theta_0)$  and  $t$  for cooling

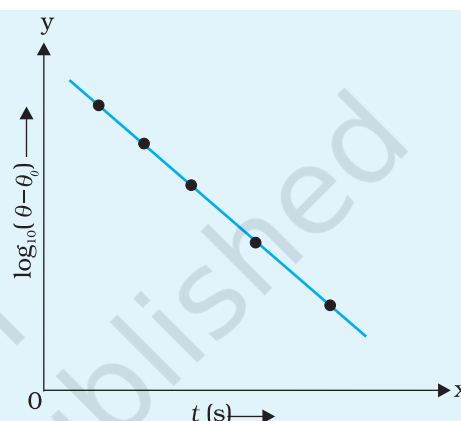

**Fig.E 14.3:** Graph between  $\log_{10}(\theta - \theta_0)$  and  $t$

## RESULT

The cooling curve is an exponential decay curve (Fig. E 14.2). It is observed from the graph that the logarithm of the excess of temperature of hot body over that of its surroundings varies linearly with time as the body cools.

## PRECAUTIONS

- The water in the calorimeter should be gently stirred continuously.
- Ideally the space between the double walls of the surrounding vessel should be filled with flowing water to make it an enclosure having a constant temperature.
- Make sure that the openings for inserting thermometers are air tight and no heat is lost to the surroundings through these.
- The starting temperature of water in the calorimeter should be about  $30^\circ\text{C}$  above the room temperature.

## SOURCES OF ERROR

- Some personal error is always likely to be involved due to delay in starting or stopping the stop-watch. Take care in starting and stopping the stop-watch.

2. The accuracy of the result depends mainly on the simultaneous measurement of temperature of hot water (decrease in temperature being fast in the beginning and then comparatively slower afterwards) and the time. Take special care while reading the stop-watch and the thermometer simultaneously.
3. If the opening for the thermometer is not airtight, some loss of heat can occur.
4. The temperature of the water in enclosure is not constant.

## DISCUSSION

Each body radiates heat and absorbs heat radiated by the other. The warmer one (here the calorimeter) radiates more and receives less. Radiation by surface occurs at all temperatures. Higher the temperature difference with the surroundings, higher is rate of heat radiation. Here the enclosure is at a lower temperature so it radiates less but receives more from the calorimeter. So, finally the calorimeter dominates in the process.

## SELF ASSESSMENT

1. State Newton's law of cooling and express this law mathematically.
2. Does the Newton's law of cooling hold good for all temperature differences?
3. How is Newton's law of cooling different from Stefan's law of heat radiation?
4. What is the shape of cooling curve?
5. Find the specific heat of a solid/liquid using Newton's law of cooling apparatus.

### SUGGESTED ADDITIONAL EXPERIMENTS/ACTIVITIES

1. Find the slope and intercept on y-axis of the straight line graph (Fig. E 14.2) you have drawn. Determine the value of constant  $k$  and the constant of integration  $c$  from this graph.

**[Hint:** Eq. (E 14.4) is similar to the equation of a straight line:  $y = m'x + c'$ , with  $m'$  as the slope of the straight line and  $c'$  the intercept on y-axis. It is clear  $m' = k'/2.303$  and  $c' = c \times 2.303$ .]

2. The cooling experiment is performed with the calorimeter, filled with same volume of water and turpentine oil successively, by maintaining the same temperature difference between the calorimeter and the surrounding enclosure. What ratio of the rates of heat loss would you expect in this case?

# EXPERIMENT 15

## A<sub>IM</sub>

- To study the relation between frequency and length of a given wire under constant tension using a sonometer.
- To study the relation between the length of a given wire and tension for constant frequency using a sonometer.

## A<sub>PPARATUS AND MATERIAL REQUIRED</sub>

Sonometer, six tuning forks of known frequencies, metre scale, rubber pad, paper rider, hanger with half-kilogram weights, wooden bridges.

### SONOMETER

It consists of a long sounding board or a hollow wooden box W with a peg G at one end and a pulley at the other end as shown in Fig E 15.1. One end of a metal wire S is attached to the peg and the other end passes over the pulley P. A hanger H is suspended from the free end of the wire. By placing slotted weights on the hanger tension is applied to the wire. By placing two bridges A and B under the wire, the length of the vibrating wire can be fixed. Position of one of the bridges, say bridge A is kept fixed so that by varying the position of other bridge, say bridge B, the vibrating length can be altered.

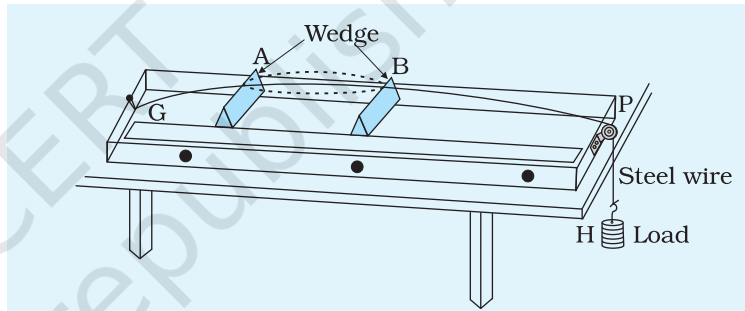

**Fig. E 15.1:** A Sonometer

## P<sub>RINCIPLE</sub>

The frequency  $n$  of the fundamental mode of vibration of a string is given by

$$n = \frac{1}{2l} \sqrt{\frac{T}{m}}$$

(E 15.1)

where  $m$  = mass per unit length of the string

$l$  = length of the string between the wedges

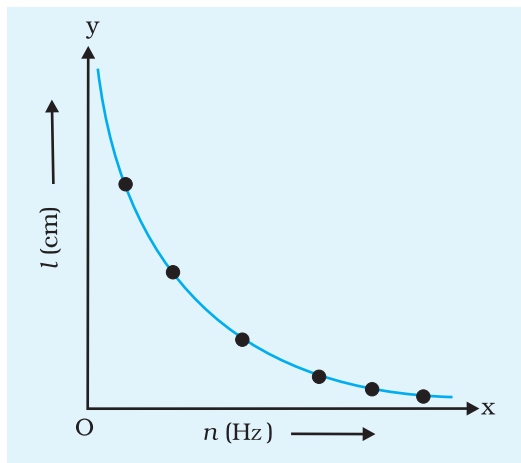

**Fig. E 15.2:** Variation of resonant length with frequency of tuning fork

$T$  = Tension in the string (including the weight of the hanger) =  $Mg$

$M$  = mass suspended, including the mass of the hanger

(a) For a given  $m$  and fixed  $T$ ,

$$n \propto \frac{1}{l} \quad \text{or} \quad n l = \text{constant.}$$

(b) If frequency  $n$  is constant, for a given wire ( $m$  is constant),

$$\frac{\sqrt{T}}{l} \text{ is constant. That is } l^2 \propto T.$$

**(i) Variation of frequency with length**

**P**ROCEDURE

1. Set up the sonometer on the table and clean the groove on the pully to ensure that it has minimum friction. Stretch the wire by placing a suitable load on the hanger.
2. Set a tuning fork of frequency  $n_1$  into vibrations by striking it against the rubber pad and hold it near one of your ears. Pluck the sonometer wire and compare the two sounds, one produced by the tuning fork and the other by the plucked wire. Make a note of difference between the two sounds.
3. Adjust the vibrating length of the wire by sliding the bridge B till the two sounds appear alike.
4. For final adjustment, place a small paper rider R in the middle of wire AB. Sound the tuning fork and place its shank stem on the bridge A or on the sonometer box. Slowly adjust the position of bridge B till the paper rider is agitated violently, which indicates resonance.

The length of the wire between A and B is the resonant length such that its frequency of vibration of the fundamental mode equals the frequency of the tuning fork. Measure this length with the help of a metre scale.

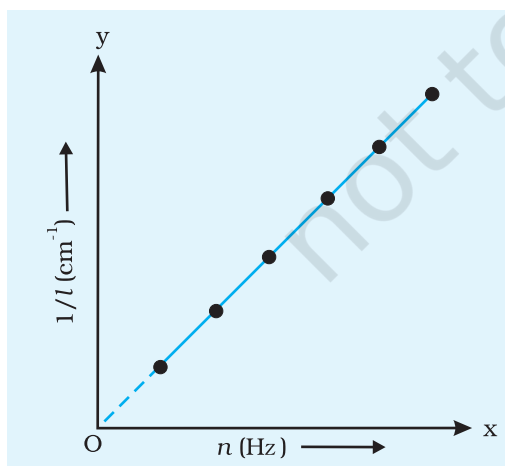

**Fig. E 15.3:** Variation of  $1/l$  with  $n$

5. Repeat the above procedures for other five tuning forks keeping the load on the hanger unchanged. Plot a graph between  $n$  and  $l$  (Fig. E 15.2)

6. After calculating frequency,  $n$  of each tuning fork, plot a graph between  $n$  and  $1/l$  where  $l$  is the resonating length as shown in Fig. E 15.3.

## OBSERVATIONS (A)

Tension (constant) on the wire (weight suspended from the hanger including its own weight)  $T = \dots N$

**Table E 15.1: Variation of frequency with length**

Frequency $n$ of tuning fork (Hz)	$n_1$	$n_2$	$n_3$	$n_4$	$n_5$	$n_6$
Resonating length $l$ (cm)						
$\frac{1}{l}$ ( $\text{cm}^{-1}$ )						
$nl$ (Hz cm)						

## CALCULATIONS AND GRAPH

Calculate the product  $nl$  for each fork. and, calculate the reciprocals,  $\frac{1}{l}$  of the resonating lengths  $l$ . Plot  $\frac{1}{l}$  vs  $n$ , taking  $n$  along  $x$  axis and  $\frac{1}{l}$  along  $y$  axis, starting from zero on both axes. See whether a straight line can be drawn from the origin to lie evenly between the plotted points.

## RESULT

Check if the product  $nl$  is found to be constant and the graph of  $\frac{1}{l}$  vs  $n$  is also a straight line. Therefore, for a given tension, the resonant length of a given stretched string varies as reciprocal of the frequency.

## DISCUSSION

1. Error may occur in measurement of length  $l$ . There is always an uncertainty in setting the bridge in the final adjustment.
2. Some friction might be present at the pulley and hence the tension may be less than that actually applied.
3. The wire may not be of uniform cross section.

**(ii) Variation of resonant length with tension for constant frequency**

1. Select a tuning fork of a certain frequency (say 256 Hz) and hang a load of 1 kg from the hanger. Find the resonant length as before.



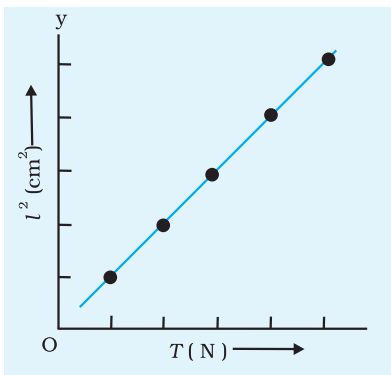

**Fig. E 15.4:** Graph between  $l^2$  and  $T$

2. Increase the load on the hanger in steps of 0.5 kg and each time find the resonating length with the same tuning fork. Do it for at least four loads.
3. Record your observations.
4. Plot graph between  $l^2$  and  $T$  as shown in Fig. E 15.4.

## OBSERVATIONS (B)

Frequency of the tuning fork = ... Hz

**Table E 15.2: Variation of resonant length with tension**

Tension applied $T$ (including weight of the hanger) (N)				
Resonating length $l$ of the wire				
$l^2$ (cm <sup>2</sup> )				
$T/l^2$ (Ncm <sup>-2</sup> )				

## CALCULATIONS AND GRAPH

Calculate the value of  $T/l^2$  for the tension applied in each case. Alternatively, plot a graph of  $l^2$  vs  $T$  taking  $l^2$  along  $y$ -axis and  $T$  along the  $x$ -axis.

## RESULT

It is found that value of  $T/l^2$  is constant within experimental error. The graph of  $l^2$  vs  $T$  is found to be a straight line. This shows that  $l^2 \propto T$  or  $l \propto \sqrt{T}$ .

Thus, the resonating length varies as square root of tension for a given frequency of vibration of a stretched string.

## PRECAUTIONS

1. Pulley should be frictionless ideally. In practice friction at the pulley should be minimised by applying grease or oil on it.
2. Wire should be free from kinks and of uniform cross section, ideally. If there are kinks, they should be removed by stretching as far as possible.

3. Bridges should be perpendicular to the wire, its height should be adjusted so that a node is formed at the bridge.
4. Tuning fork should be vibrated by striking its prongs against a soft rubber pad.
5. Load should be removed after the experiment.

## SOURCES OF ERROR

1. Pulley may not be frictionless.
2. Wire may not be rigid and of uniform cross section.
3. Bridges may not be sharp.

## DISCUSSION

1. Error may occur in measurement of length  $l$ . There is always an uncertainty in setting the bridge in the final adjustment.
2. Some friction might be present at the pulley and hence the tension may be less than that actually applied.
3. The wire may not be of uniform cross section.
4. Care should be taken to hold the tuning fork by the shank only.

## SELF ASSESSMENT

1. What is the principle of superposition of waves?
2. What are stationary waves?
3. Under what circumstances are stationary waves formed?
4. Identify the nodes and antinodes in the string of your sonometer.
5. What is the ratio of the first three harmonics produced in a stretched string fixed at two ends?
6. Keeping material of wire and tension fixed, how will the resonant length change if the diameter of the wire is increased?

### SUGGESTED ADDITIONAL EXPERIMENTS/ACTIVITIES

1. Take wires of the same material but of three different diameters and find the value of  $l$  for each of these for a given frequency,  $n$  and tension,  $T$ .
2. Plot a graph between the value of  $m$  and  $\frac{1}{l^2}$  obtained, in 1 above, with  $m$  along X axis.
3. Pluck the string of a stringed musical instrument like a sitar, violin or guitar with different lengths of string for same tension or same length of string with different tension. Observe how the frequency of the sound changes.

# EXPERIMENT 16

## AIM

To determine the velocity of sound in air at room temperature using a resonance tube.

## APPARATUS AND MATERIAL REQUIRED

Resonance tube apparatus, a tuning fork of known frequency (preferably of 480 Hz or 512 Hz), a rubber pad, a thermometer, spirit level, a set-square, beaker and water.

## PRINCIPLE

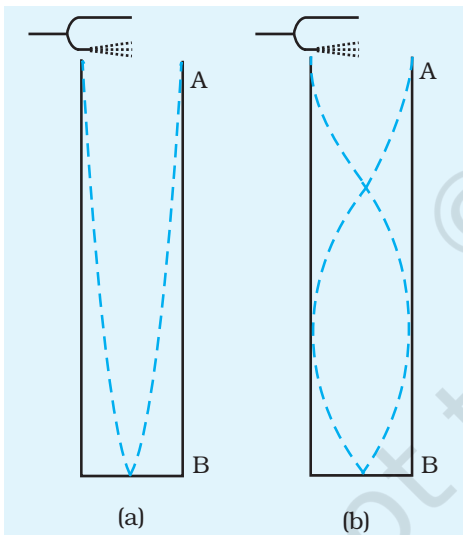

**Fig. E 16.1:** Formation of standing wave in glass tube AB closed at one end

When a vibrating tuning fork of known frequency  $\nu$  is held over the top of an air column in a glass tube AB (Fig. E 16.1), a standing wave pattern could be formed in the tube. Under the right conditions, a superposition between a forward moving and reflected wave occurs in the tube to cause resonance. This gives a very noticeable rise in the amplitude, or loudness, of the sound. In a closed organ pipe like a resonance tube, there is a zero amplitude point at the closed end (Fig. E 16.2). For resonance to occur, a node must be formed at the closed end and an antinode must be formed at the open end. Let the first loud sound be heard at length  $l_1$  of the air column [Fig. E 16.2(a)]. That is, when the natural frequency of the air column of length  $l_1$  becomes equal to the natural frequency of the tuning fork, so that the air column vibrates with the maximum amplitude. In fact the length of air column vibrating is slightly longer than the length of the air column in tube AB. Thus,

$$\frac{\lambda}{4} = l_1 + e \quad \text{(E 16.1)}$$

where  $e$  ( $= 0.6r$ , where  $r$  = radius of the glass tube) is the end correction for the resonance tube and  $\lambda$  is the wave-length of the sound produced by the tuning fork.

Now on further lowering the closed end of the tube AB, let the second resonance position be heard at length  $l_2$  of the air column in the tube

[Fig. E 16.2(b)]. This length  $l_2$  would approximately be equal to three quarters of the wavelength. That is,

$$(E\ 16.2) \quad \frac{3\lambda}{4} = l_2 + e$$

Subtracting Eq. (E 16.1) from Eq. (E 16.2) gives

$$(E\ 16.3) \quad \lambda = 2 (l_2 - l_1)$$

Thus, the velocity of sound in air at room temperature ( $v = \nu\lambda$ ) would be  $v = 2\nu (l_2 - l_1)$ .

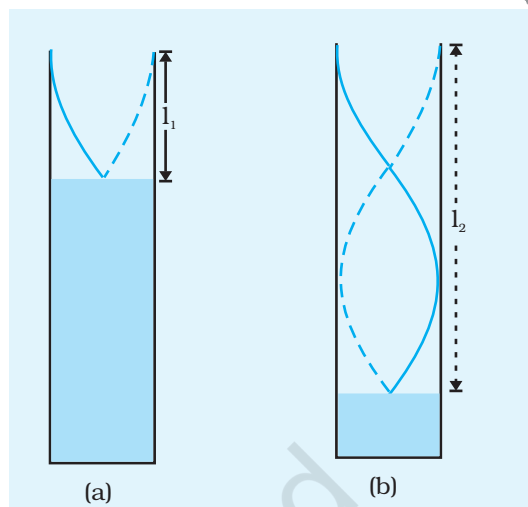

**Fig. E 16.2:** Vibrations in a resonance tube

## P ROCEDURE

### ADJUSTMENT OF RESONANCE TUBE

The apparatus usually consists of a narrow glass tube about a metre long and 5 cm in diameter, rigidly fixed in its vertical position with a wooden stand. The lower end of this tube is attached to a reservoir by a rubber tube. Using a clamp, the reservoir can be made to slide up or down along a vertical rod. A pinch cock is provided with the rubber tube to keep the water level (or the length of air column) fixed in the tube. A metre scale is also fixed along the tube. The whole apparatus is fixed on a horizontal wooden base that can be levelled using the screws provided at the bottom. Both the reservoir and tube contain water. When reservoir is raised the length of the air column in the tube goes down, and when it is lowered the length of the air column in the tube goes up. Now:-

1. Set the resonance tube vertical with the help of a spirit level and levelling screws provided at the bottom of the wooden base of the apparatus.
2. Note the room temperature with a thermometer.
3. Note the frequency  $\nu$  of given tuning fork.
4. Fix the reservoir to the highest point of the vertical rod with the help of clamp.

#### **De-termination of First Resonance Position**

5. Fill the water in the reservoir such that the level of water in the tube reaches up to its open end.
6. Close the pinch cock and lower down the position of reservoir on the vertical rod.
7. Gently strike the given tuning fork on a rubber pad and put it nearly one cm above the open end of the tube. Keep both the

prongs of the tuning fork parallel to the ground and lying one above the other so that the prongs vibrate in the vertical plane. Try to listen the sound being produced in the tube. It may not be audible in this position.

8. Slowly loosen the pinch cock to let the water level fall in the tube very slowly. Keep bringing the tuning fork near the open end of the resonance tube, notice the increasing loudness of the sound.
9. Repeat steps 7 and 8 till you get the exact position of water level in the tube for which the intensity of sound being produced in the tube is maximum. This corresponds to *the first resonance position or fundamental node*, if the length of air column is minimum. Close the pinch cock at this position and note the position of water level or length  $l_1$  of air column in the tube [Fig. E 16.2]. This is the determination of first resonance position while the level of water is falling in the tube.
10. Repeat steps (5) to (9) to confirm the first resonance position.
11. Next find out the first resonance position by gradually raising the level of water in resonance tube, and holding the vibrating tuning fork continuously on top of its open end. Fix the tube at the position where the sound of maximum intensity is heard.

#### **Determination of Second Resonance Position**

12. Lower the position of the water level further in the resonance tube by sliding down the position of reservoir on the vertical stand and opening the pinch cock till the length of air column in the tube increases about three times of the length  $l_1$ .
13. Find out the second resonance position and determine the length of air column  $l_2$  in the tube with the same tuning fork having frequency  $\nu_1$  and confirm the length  $l_2$  by taking four readings, two when the level of water is falling and the other two when the level of water is rising in the tube.
14. Repeat steps (5) to (13) with a second tuning fork having frequency  $\nu_2$  and determine the first and second resonance positions.
15. Calculate the velocity of sound in each case.

### OBSERVATIONS

1. Temperature of the room  $\theta = \dots$  °C
2. Frequency of first tuning fork,  $\nu_1 = \dots$  Hz
3. Frequency of second tuning fork,  $\nu_2 = \dots$  Hz

**Table E 16.1: Determination of length of the resonant air columns**

Frequency of tuning fork used	S. No.	length $l_1$ for the first resonance position of the tube			length $l_2$ for the second resonance position of the tube		
		Water level is falling	Water level is rising	Mean length, $l_1$ cm	Water level is falling	Water level is rising	Mean length, $l_2$ cm
$\nu_1 = \dots$ Hz	1 2						
$\nu_2 = \dots$ Hz	1 2						

## CALCULATIONS

(i) For first tuning fork having frequency  $\nu_1 = \dots$  Hz

$$\text{Velocity of sound in air } v_1 = 2 \nu_1 (l_2 - l_1) = \dots \text{ ms}^{-1}$$

(ii) For second tuning fork having frequency  $\nu_2 = \dots$  Hz

$$\text{Velocity of sound in air } v_2 = 2 \nu_2 (l_2 - l_1) = \dots \text{ ms}^{-1}$$

Obtain the mean velocity  $v$  of sound in air.

## RESULT

The velocity of sound  $v$  in air at room temperature is

$$\frac{v_1 + v_2}{2} = \dots \text{ ms}^{-1}$$

## PRECAUTIONS

1. The resonance tube should be kept vertical using the levelling screws.
2. The experiment should be performed in a quiet atmosphere so that the resonance positions may be identified properly.
3. Striking of tuning fork on rubber pad must be done very gently.
4. The lowering and raising of water level in the resonance tube should be done very slowly.
5. The choice of frequencies of the tuning forks being used should be such that the two resonance positions may be achieved in the air column of the resonance tube.
6. The vibrating tuning fork must be kept about 1 cm above the top of the resonance tube. In any case it should not touch the walls of the resonance tube.

7. The prongs of the vibrating tuning fork must be kept parallel to the ground and keeping one over the other so that the vibrations reaching the air inside the tube are vertical.
8. Room temperature during the performance of experiment should be measured two to three times and a mean value should be taken.

## SOURCES OF ERROR

---

1. The air inside the tube may not be completely dry and the presence of water vapours in the air column may exhibit a higher value of velocity of sound.
2. Resonance tube must be of uniform area of cross-section.
3. There must be no wind blowing in the room.

## DISCUSSION

---

1. Loudness of sound in second resonance position is lower than the loudness in first resonance. We determine two resonance positions in this experiment to apply end correction. But the experiment can also be conducted by finding first resonance position only and applying end correction in resonating length as  $e = 0.6 r$ .
2. For a given tuning fork, change in the resonating length of air column in 2<sup>nd</sup> resonance does not change the frequency, wavelength or velocity of sound. Thus, the second resonance is not the overtone of first resonance.

## SELF ASSESSMENT

---

1. Is the velocity of sound temperature dependent? If yes, write the relation.
2. What would happen if resonance tube is not vertical?
3. Name the phenomenon responsible for the resonance in this experiment.
4. Write two other examples of resonance of sound from day to day life.

### SUGGESTED ADDITIONAL EXPERIMENTS/ACTIVITIES

---

1. Calculate the end correction in the resonance tube.
2. Compare the end correction required for the resonance tubes of different diameters and study the relation between the end correction and the diameter of the tube.
3. Perform the same experiment with an open pipe.

# EXPERIMENT 17

## AIM

To determine the specific heat capacity of a given (i) and solid (ii) a liquid by the method of mixtures.

## APPARATUS AND MATERIAL REQUIRED

Copper calorimeter with lid, stirrer and insulating cover (the lid should have provision to insert thermometer in addition to the stirrer), two thermometers (0 °C to 100 °C or 110 °C with a least count of 0.5 °C), a solid, preferably metallic (brass/copper/steel/aluminium) cylinder which is insoluble in given liquid and water, given liquid, two beakers (100 mL and 250 mL), a heating device (heater/hot plate/gas burner); physical balance, spring balance with weight box (including fractional weights), a piece of strong non-flexible thread (25-30 cm long), water, laboratory stand, tripod stand and wire gauze.

## PRINCIPLE / THEORY

For a body of mass  $m$  and specific heat  $s$ , the amount of heat  $Q$  lost/gained by it when its temperature falls/rises by  $\Delta t$  is given by

$$\Delta Q = ms \Delta t$$

(E 17.1)

**Specific heat capacity:** It is the amount of heat required to raise the temperature of unit mass of a substance through 1°C. Its S.I unit is  $\text{Jkg}^{-1} \text{K}^{-1}$ .

**Principle of Calorimetry:** If bodies of different temperatures are brought in thermal contact, the amount of heat lost by the body at higher temperature is equal to the amount of heat gained by the body at lower temperature, at thermal equilibrium, provided no heat is lost to the surrounding.

**(a) Specific heat capacity of given solid by method of mixtures**

## PROCEDURE

1. Set the physical balance and make sure there is no zero error.
2. Weigh the empty calorimeter with stirrer and lid with the physical balance/spring balance. Ensure that calorimeter is clean and dry.



Note the mass  $m_1$  of the calorimeter. Pour the given water in the calorimeter. Make sure that the quantity of water taken would be sufficient to completely submerge the given solid in it. Weigh the calorimeter with water along with the stirrer and the lid and note its mass  $m_2$ . Place the calorimeter in its insulating cover.

3. Dip the solid in water and take it out. Now shake it to remove water sticking to its surface. Weigh the wet solid with the physical balance and note down its mass  $m_3$ .
4. Tie the solid tightly with the thread at its middle. Make sure that it can be lifted by holding the thread without slipping.

Place a 250 mL beaker on the wire gauze kept on a tripod stand as shown in the Fig. E 17.1(a). Fill the beaker up to the half with water. Now suspend the solid in the beaker containing water by tying the other end of the thread to a laboratory stand. The solid should be completely submerged in water and should be at least 0.5 cm below the surface. Now heat the water with the solid suspended in it [Fig. E 17.1 (a)].

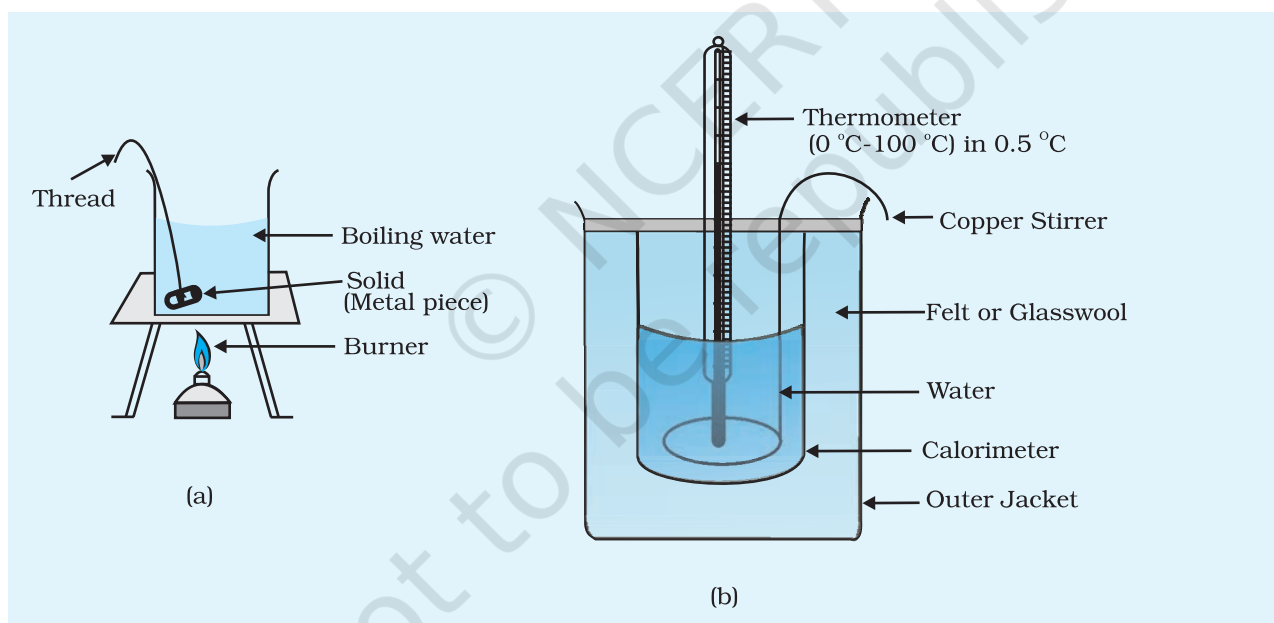

**Fig. E 17.1:** Experimental setup for determining specific heat of a given solid

5. Note the least count of the thermometer. Measure the temperature of the water taken in the calorimeter. Record the temperature  $t_1$  of the water.
6. Let the water in the beaker boil for about 5-10 minutes. Now measure the temperature  $t_2$  of the water with the other thermometer and record the same. Holding the solid with the thread tied to it,

remove it from the boiling water, shake it to remove water sticking on it and quickly put it in the water in the calorimeter and replace the lid immediately (Fig. E 17.1 (b)). Stir the water with the stirrer. Measure the temperature of the water once equilibrium is attained, that is, temperature of the mixture becomes constant. Record this temperature as  $t_3$ .

## OBSERVATIONS

Mass of the empty calorimeter with stirrer ( $m_1$ )	= ... g
Mass of the calorimeter with water ( $m_2$ )	= ... g
Mass of solid ( $m_3$ )	= ... g
Initial temperature of the water ( $t_1$ )	= ... °C = ... K
Temperature of the solid in boiling water ( $t_2$ )	= ... °C = ... K
Temperature of the mixture ( $t_3$ )	= ... °C
Specific heat capacity of material of calorimeter $s_1$	= ... Jkg <sup>-1</sup> °C <sup>-1</sup> (Jkg <sup>-1</sup> K <sup>-1</sup> )
Specific heat capacity of water ( $s$ )	= ... Jkg <sup>-1</sup> K <sup>-1</sup>

## CALCULATIONS

1. Mass of the water in calorimeter ( $m_2 - m_1$ ) = ... g = ... kg
2. Change in temperature of liquid and calorimeter ( $t_3 - t_1$ ) = ... °C
3. Change in temperature of solid ( $t_2 - t_3$ ) = ... °C

Heat given by solid in cooling from  $t_2$  to  $t_3$ .

= Heat gained by liquid in raising its temperature from  $t_1$  to  $t_3$  + heat gained by calorimeter in raising its temperature from  $t_1$  to  $t_3$ .

$$m_3 s_o (t_2 - t_3) = (m_2 - m_1) s (t_3 - t_1) + m_1 s_1 (t_3 - t_1)$$

$$s_o = \frac{(m_2 - m_1) s (t_3 - t_1) + m_1 s_1 (t_3 - t_1)}{m_3 (t_2 - t_3)} = \dots \text{ J kg}^{-1} \text{ °C}^{-1}$$

### (b) Specific heat capacity of given liquid by method of mixtures

## PROCEDURE

1. Set the physical balance and make sure there is no zero error.
2. Weigh the empty calorimeter with stirrer and lid with the physical balance/spring balance. Ensure that calorimeter is clean and dry. Note the mass  $m_1$  of the calorimeter. Pour the

given liquid in the calorimeter. Make sure that the quantity of liquid taken would be sufficient to completely submerge the solid in it. Weigh the calorimeter with liquid along with the stirrer and the lid and note its mass  $m_2$ . Place the calorimeter in its insulating cover.

3. Take a metallic cylinder whose specific heat capacity is known. Dip it in water in a container and shake it to remove the water sticking to its surface. Weigh the wet solid with the physical balance and note down its mass  $m_3$ .
4. Tie the solid tightly with the thread at its middle. Make sure that it can be lifted by holding the thread without slipping.

Place a 250 mL beaker on the wire gauze kept on a tripod stand as shown in Fig. E 17.1(a). Fill the beaker up to half with water. Now suspend the solid in the beaker containing water by tying the other end of the thread to a laboratory stand. The solid should be completely submerged in water and should be at least 0.5 cm below the surface. Now heat the water with the solid suspended in it [Fig. E 17.1(a)].

5. Note the least count of the thermometer. Measure the temperature of the water taken in the calorimeter. Record the temperature  $t_1$  of the water.
6. Let the liquid in the beaker boil for about 5-10 minutes. Now measure the temperature  $t_2$  of the liquid with the other thermometer and record the same. Holding the solid with the thread tied to it remove it from the boiling water, shake it to remove water sticking on it and quickly put it in the liquid in the calorimeter and replace the lid immediately [Fig. E 17.1(b)]. Stir it with the stirrer. Measure the temperature of the liquid once equilibrium is attained, that is, temperature of the mixture becomes constant. Record this temperature as  $t_3$ .

## OBSERVATIONS

---

Mass of the empty calorimeter with stirrer ( $m_1$ )	= ... g
Mass of the calorimeter with liquid ( $m_2$ )	= ... g
Mass of solid ( $m_3$ )	= ... g
Initial temperature of the liquid ( $t_1$ )	= °C = ... K
Temperature of the solid in boiling water ( $t_2$ )	= °C = ... K
Temperature of the mixture ( $t_3$ )	= °C = ... K
Specific heat capacity of material of calorimeter $s_1$	= ... Jkg <sup>-1</sup> °C <sup>-1</sup> (Jkg <sup>-1</sup> K <sup>-1</sup> )
Specific heat capacity of solid ( $s_2$ )	= ... Jkg <sup>-1</sup> K <sup>-1</sup>

---

## CALCULATIONS

1. Mass of the liquid in calorimeter ( $m_2 - m_1$ ) = ... g = ... kg
2. Change in temperature of liquid and calorimeter ( $t_3 - t_1$ ) = ... °C
3. Change in temperature of solid ( $t_2 - t_3$ ) = ... °C

Heat given by solid in cooling from  $t_2$  to  $t_3$ .

= Heat gained by liquid in raising its temperature from  $t_1$  to  $t_3$  + heat gained by calorimeter in raising its temperature from  $t_1$  to  $t_3$ .

$$m_3 s_0 (t_2 - t_3) = (m_2 - m_1) s (t_3 - t_1) + m_1 s_1 (t_3 - t_1)$$

$$s = \frac{m_3 s_0 (t_2 - t_3) - m_1 s_1 (t_3 - t_1)}{(m_2 - m_1)(t_3 - t_1)} = \dots \text{ J kg}^{-1} \text{ °C}^{-1}$$

## RESULT

- (a) The specific heat of the given solid is ...  $\text{J kg}^{-1} \text{ K}^{-1}$  within experimental error.
- (b) The specific heat of the given liquid is ...  $\text{J kg}^{-1} \text{ K}^{-1}$  within experimental error.

## PRECAUTIONS

1. Physical balance should be in proper working condition and ensure that there is no zero error.
2. The two thermometers used should be of the same range and least count.
3. The solid used should not be chemically reactive with the liquid used or water.
4. The calorimeter should always be kept in its insulated cover and at a sufficient distance from the source of heat and should not be exposed to sunlight so that it absorbs no heat from the surrounding.
5. The solid should be transferred quickly so that its temperature is same as recorded when it is dropped in the liquid.
6. Liquid should not be allowed to splash while dropping the solid in it in the calorimeter. It is advised that the solid should be lowered gently into the liquid with the help of the thread tied to it.
7. While measuring the temperature, the thermometers should always be held in vertical position. The line of sight should be perpendicular to the mercury level while recording the temperature.

## SOURCES OF ERROR

---

1. Radiation losses cannot be completely eliminated.
2. Heat loss that takes place during the short period while transferring hot solid into calorimeter, cannot be accounted for.
3. Though mercury in the thermometer bulb has low specific heat, it absorbs some heat.
4. There may be some error in measurement of mass and temperature.

## DISCUSSION

---

1. There may be some heat loss while transferring the solid, from boiling water to the liquid kept in the calorimeter. Heat loss may also occur due to time lapsed between putting of hot solid in calorimeter and replacing its lid.
2. The insulating cover of the calorimeter may not be a perfect insulator.
3. Error in measurement of mass of calorimeter, calorimeter with liquid and that of the solid may affect the calculation of specific heat capacity of the liquid.
4. Calculation of specific heat capacity of the liquid may also be affected by the error in measurement of temperatures.
5. Even though the metal piece is kept in boiling water, it may not have exactly the same temperature as that of boiling water.

## SELF ASSESSMENT

---

1. What is water equivalent?
2. Why do we generally use a calorimeter made of copper?
3. Why is it important to stir the contents before taking the temperature of the mixture?
4. Is specific heat a constant quantity?
5. What is thermal equilibrium?

### SUGGESTED ADDITIONAL EXPERIMENTS/ACTIVITIES

---

We can verify the principle of calorimetry, if specific heat capacity of the solid and the liquid are known.