

3

A PEEK BEYOND THE POINT



3.1 The Need for Smaller Units

Sonu's mother was fixing a toy. She was trying to join two pieces with the help of a screw. Sonu was watching his mother with great curiosity. His mother was unable to join the pieces. Sonu asked why. His mother said that the screw was not of the right size.



She brought another screw from the box and was able to fix the toy. The two screws looked the same to Sonu. But when he observed them closely, he saw they were of slightly different lengths.



Sonu was fascinated by how such a small difference in lengths could matter so much. He was curious to know the difference in lengths. He was also curious to know how little the difference was because the screws looked nearly the same.

In the following figure, screws are placed above a scale. Measure them and write their length in the space provided.

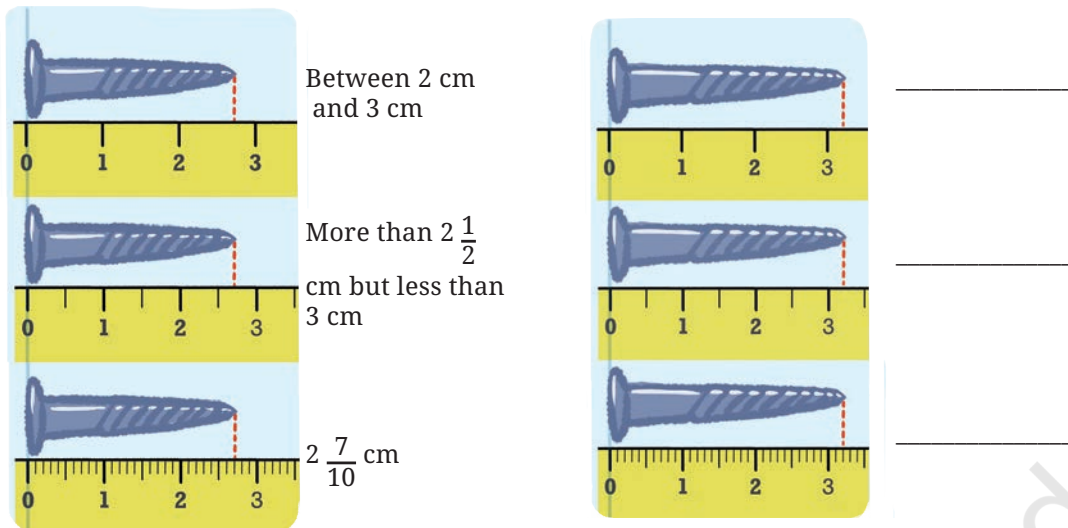

? Which scale helped you measure the length of the screws accurately? Why?

? What is the meaning of $2\frac{7}{10}$ cm (the length of the first screw)?

As seen on the ruler, the unit length between two consecutive numbers is divided into 10 equal parts. To get the length $2\frac{7}{10}$ cm, we go from 0 to 2 and then take seven parts of $\frac{1}{10}$. The length of the screw is 2 cm and $\frac{7}{10}$ cm. Similarly, we can make sense of the length $3\frac{2}{10}$ cm.

We read $2\frac{7}{10}$ cm as **two and seven-tenth centimeters**, and $3\frac{2}{10}$ cm as **three and two-tenth centimeters**.

? Can you explain why the unit was divided into smaller parts to measure the screws?

? Measure the following objects using a scale and write their measurements in centimeters (as shown earlier for the lengths of the screws): pen, sharpener, and any other object of your choice.

? Write the measurements of the objects shown in the picture:

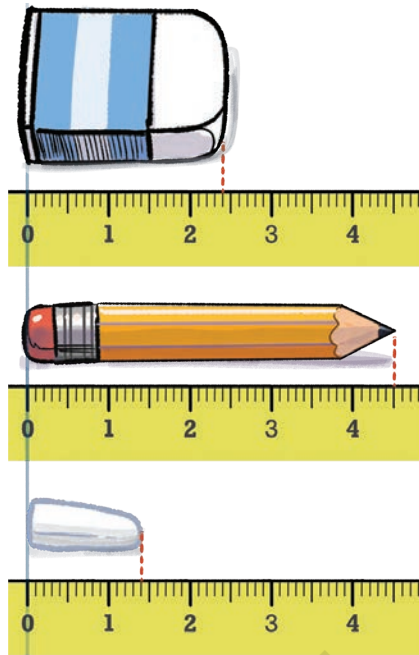

As seen here, when exact measures are required we can make use of smaller units of measurement.

3.2 A Tenth Part

The length of the pencil shown in the figure below is $3\frac{4}{10}$ units, which can also be read as 3 units and four one-tenths, i.e., $(3 \times 1) + (4 \times \frac{1}{10})$ units.

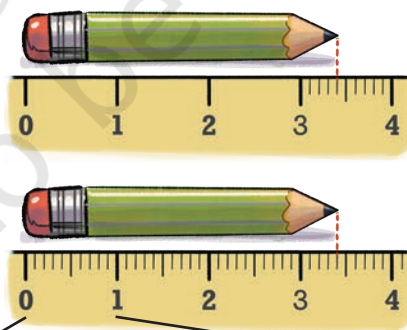

$$\frac{1}{10} + \frac{1}{10} + \frac{1}{10} + \frac{1}{10} + \frac{1}{10} + \frac{1}{10} + \frac{1}{10} + \frac{1}{10} + \frac{1}{10} + \frac{1}{10}$$

$$= 10 \text{ times } \frac{1}{10} = 10 \times \frac{1}{10} = 1 \text{ unit}$$

This length is the same as 34 one-tenths units because 10 one-tenths units make one unit.

$$34 \times \frac{1}{10} = \frac{34}{10} = \frac{10}{10} + \frac{10}{10} + \frac{10}{10} + \frac{4}{10} \text{ (34 one-tenths)}$$

$$= 1 + 1 + 1 + \frac{4}{10} \text{ (3 and 4 one-tenths)}$$

A few numbers with fractional units are shown below along with how to read them.

$4 \frac{1}{10}$ → ‘four and one-tenth’

$\frac{4}{10}$ → ‘four one-tenths’ or ‘four-tenths’

$\frac{41}{10}$ → ‘forty-one one-tenths’ or ‘forty-one tenths’

$41 \frac{1}{10}$ → ‘forty-one and one-tenth’

For the objects shown below, write their lengths in two ways and read them aloud. An example is given for the USB cable. (Note that the unit length used in each diagram is not the same).

The length of the USB cable is 4 and $\frac{8}{10}$ units or $\frac{48}{10}$ units.

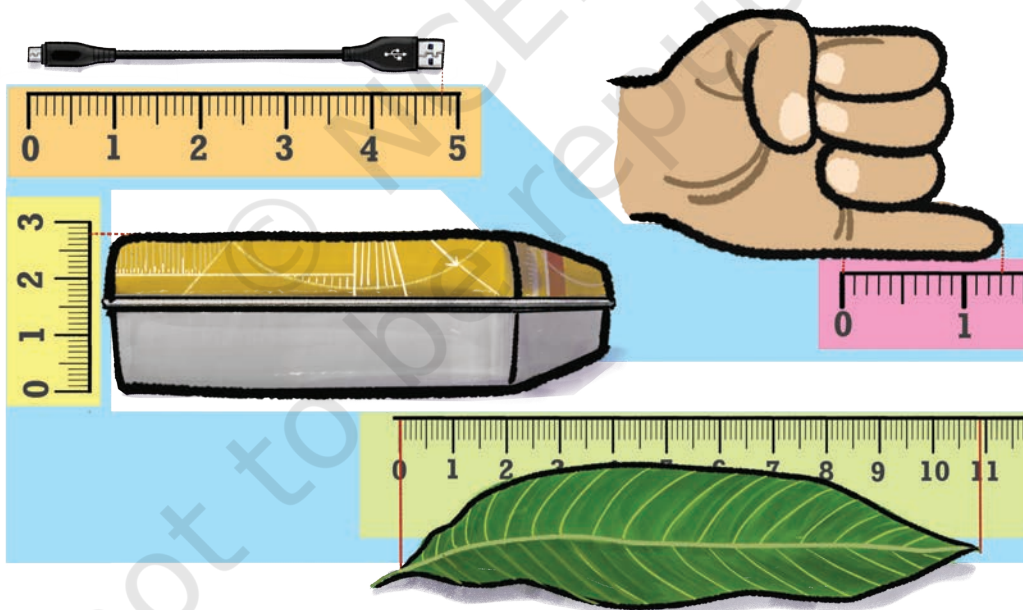

? Arrange these lengths in increasing order:

(a) $\frac{9}{10}$

(b) $1 \frac{7}{10}$

(c) $\frac{130}{10}$

(d) $13 \frac{1}{10}$

(e) $10 \frac{5}{10}$

(f) $7 \frac{6}{10}$

(g) $6 \frac{7}{10}$

(h) $\frac{4}{10}$

- ❓ Arrange the following lengths in increasing order: $4\frac{1}{10}$, $\frac{4}{10}$, $\frac{41}{10}$, $41\frac{1}{10}$.
- ❓ Sonu is measuring some of his body parts. The length of Sonu's lower arm is $2\frac{7}{10}$ units, and that of his upper arm is $3\frac{6}{10}$ units. What is the total length of his arm?

To get the total length, let us see the lower and upper arm length as 2 units and 7 one-tenths, and 3 units and 6 one-tenths, respectively.

So, there are (2 + 3) units and (7 + 6) one-tenths. Together, they make 5 units and 13 one-tenths. But 13 one-tenths is 1 unit and 3 one-tenths. So, the total length is 6 units and 3 one-tenths.

$$\begin{aligned}
 \text{(a)} \quad & (2 + 3) + \left(\frac{7}{10} + \frac{6}{10}\right) \\
 & = (2 + 3) + \left(\frac{13}{10}\right) \\
 & = 5 + \frac{13}{10} \\
 & = 5 + \frac{10}{10} + \frac{3}{10} = 5 + 1 + \frac{3}{10} \\
 & = 6 + \frac{3}{10} \\
 & = 6\frac{3}{10}
 \end{aligned}$$

$$\begin{aligned}
 \text{(b)} \quad & 2\frac{7}{10} \\
 & + 3\frac{6}{10} \\
 \hline
 & = 5\frac{13}{10} \\
 & = 6\frac{3}{10}
 \end{aligned}$$

Or, both the lengths can be converted to tenths and then added:

- (c) 27 one-tenths and 36 one-tenths is 63 one-tenths

$$\frac{27}{10} + \frac{36}{10} = \frac{63}{10}$$

$\frac{63}{10}$ is the same as 60 one-tenths $\left(\frac{60}{10}\right)$ and 3 one-tenths $\left(\frac{3}{10}\right)$, which is

one-tenths. So we split a unit from 12 and convert it to 10 one-tenths. Now, the number has 11 units and 14 one-tenths. We subtract 7 one-tenths from 14 one-tenths and then subtract 6 units from 11 units.

- ① Try computing the difference by converting both lengths to tenths.
- ② A Celestial Pearl Danio's length is $2\frac{4}{10}$ cm, and the length of a Philippine Goby is $\frac{9}{10}$ cm. What is the difference in their lengths?
- ③ How big are these fish compared to your finger?



Celestial Pearl Danio



Philippine Goby

- ④ Observe the given sequences of numbers. Identify the change after each term and extend the pattern:

- (a) $4, 4\frac{3}{10}, 4\frac{6}{10},$ _____, _____, _____, _____
- (b) $8\frac{2}{10}, 8\frac{7}{10}, 9\frac{2}{10},$ _____, _____, _____, _____
- (c) $7\frac{6}{10}, 8\frac{7}{10},$ _____, _____, _____, _____
- (d) $5\frac{7}{10}, 5\frac{3}{10},$ _____, _____, _____, _____
- (e) $13\frac{5}{10}, 13, 12\frac{5}{10},$ _____, _____, _____, _____
- (f) $11\frac{5}{10}, 10\frac{4}{10}, 9\frac{3}{10},$ _____, _____, _____, _____

3.3 A Hundredth Part

The length of a sheet of paper was $8\frac{9}{10}$ units, which can also be said as 8 units and 9 one-tenths. It is folded in half along its length. What is its length now?



We can say that its length is between $4\frac{4}{10}$ units and $4\frac{5}{10}$ units. But we cannot state its exact measurement, since there are no markings. Earlier, we split a unit into 10 one-tenths to measure smaller lengths. We can do something similar and split each one-tenth into 10 parts.

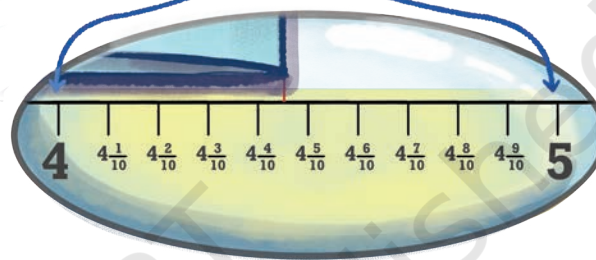
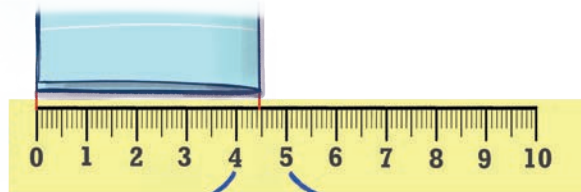
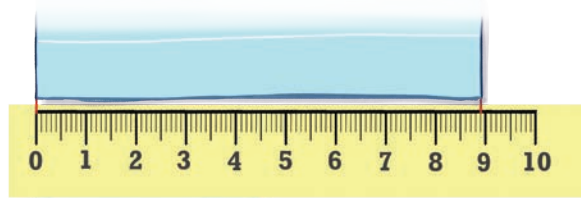

- ① What is the length of this smaller part? How many such smaller parts make a unit length?

As shown in the figure below, each one-tenth has 10 smaller parts, and there are 10 one-tenths in a unit; therefore, there will be 100 smaller parts in a unit. Therefore, one part's length will be $\frac{1}{100}$ of a unit.

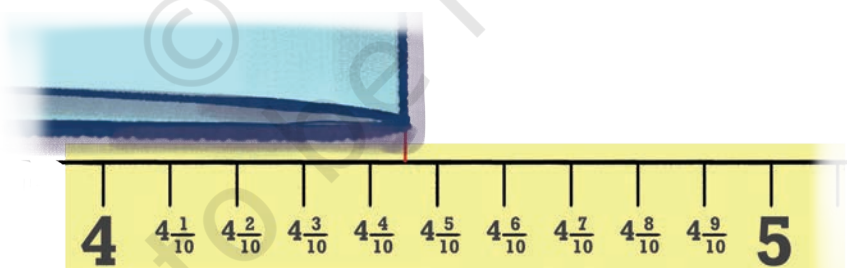

Returning to our question, what is the length of the folded paper?

We can see that it ends at $4\frac{4}{10}\frac{5}{100}$, read as **4 units and 4 one-tenths and 5 one-hundredths.**

- ② How many one-hundredths make one-tenth? Can we also say that the length is 4 units and 45 one-hundredths?



- ⑦ Observe the figure below. Notice the markings and the corresponding lengths written in the boxes when measured from 0. Fill the lengths in the empty boxes.

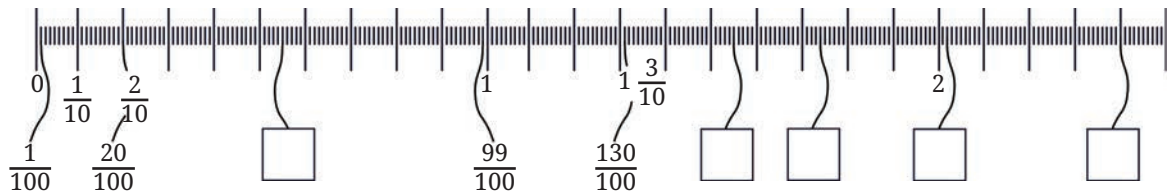

The length of the wire in the first picture is given in three different ways. Can you see how they denote the same length?

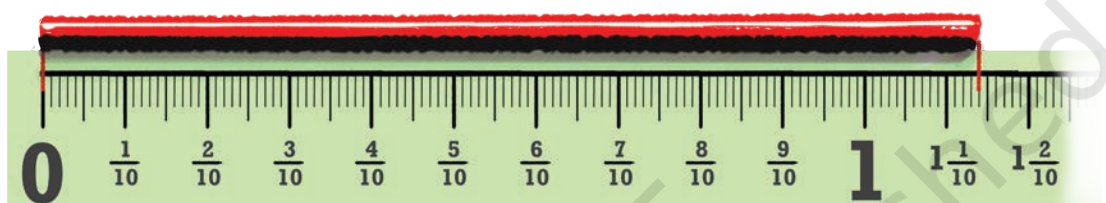

$1 \frac{1}{10} \frac{4}{100}$ **One and one-tenth and four-hundredths**

$1 \frac{14}{100}$ **One and fourteen-hundredths**

$\frac{114}{100}$ **One Hundred and Fourteen-hundredths**

- ⑦ For the lengths shown below write the measurements and read out the measures in words.

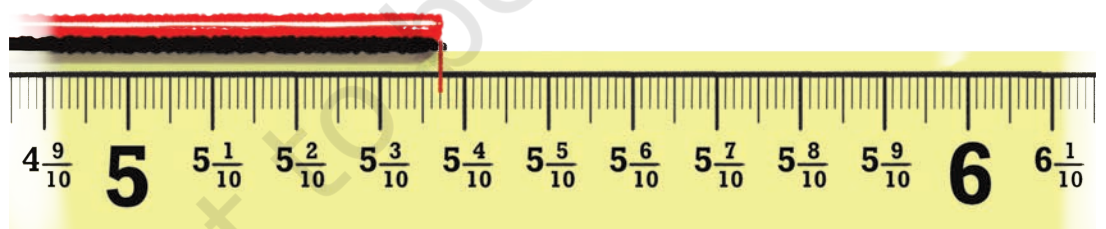

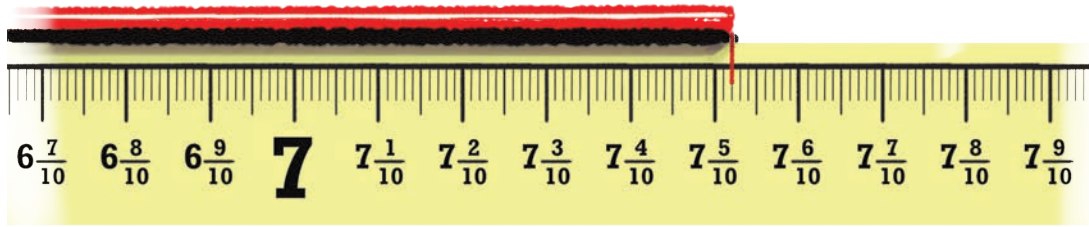

In each group, identify the longest and the shortest lengths. Mark each length on the scale.

(a) $\frac{3}{10}$, $\frac{3}{100}$, $\frac{33}{100}$



(b) $3\frac{1}{10}$, $\frac{30}{10}$, $1\frac{3}{10}$



(c) $\frac{45}{100}$, $\frac{54}{100}$, $\frac{5}{10}$, $\frac{4}{10}$



(d) $3\frac{6}{10}$, $3\frac{6}{100}$, $3\frac{6}{10}\frac{6}{100}$

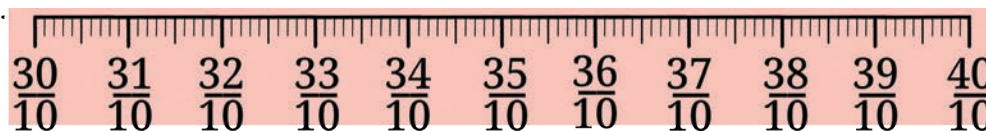

(e) $\frac{8}{10} \frac{2}{100}, \frac{9}{100}, 1 \frac{8}{100}$



(f) $7 \frac{3}{10} \frac{5}{100}, 7 \frac{5}{10}, 7 \frac{41}{100}$

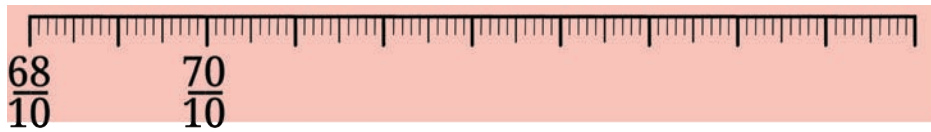

(g) $\frac{65}{10} \frac{15}{100}, 5 \frac{87}{100}, 5 \frac{7}{100}$

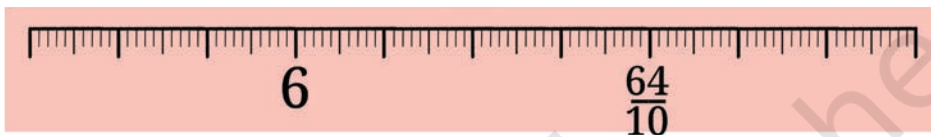

❓ What will be the sum of $15 \frac{3}{10} \frac{4}{100}$ and $2 \frac{6}{10} \frac{8}{100}$?

This can be solved in different ways. Some are shown below.

(a) Method 1

$$\begin{aligned} & (15 + 2) + \left(\frac{3}{10} + \frac{6}{10}\right) + \left(\frac{4}{100} + \frac{8}{100}\right) \\ &= 17 + \frac{9}{10} + \frac{12}{100} \\ &= 17 + \frac{9}{10} + \frac{1}{10} + \frac{2}{100} \\ &= 17 + \frac{10}{10} + \frac{2}{100} \\ &= 18 \frac{2}{100}. \end{aligned}$$

10 hundredths is the same as 1 tenth.

(b) Method 2

$$\begin{array}{r} 15 \frac{3}{10} \frac{4}{100} \\ + \quad 2 \frac{6}{10} \frac{8}{100} \\ \hline = 17 \frac{9}{10} \frac{12}{100} \\ = 17 \frac{10}{10} \frac{2}{100} \\ = 18 \frac{2}{100} \end{array}$$

❓ Are both these methods different?

❓ Observe the addition done below for $483 + 268$. Do you see any similarities between the methods shown above?



$$\begin{aligned} & (400 + 80 + 3) + (200 + 60 + 8) \\ &= (400 + 200) + (80 + 60) + (3 + 8) \\ &= 600 + 140 + 11 \\ &= 600 + 150 + 1 \\ &= 700 + 50 + 1 \\ &= 751 \end{aligned}$$

One can also find the sum $15 \frac{3}{10} \frac{4}{100} + 2 \frac{6}{10} \frac{8}{100}$ by converting to hundredths, as follows.

$$\begin{aligned} \text{(c)} \quad & (15 + 2) + \left(\frac{34}{100} + \frac{68}{100} \right) \\ &= 17 + \frac{102}{100} \\ &= 17 + 1 + \frac{2}{100} \\ &= 18 \frac{2}{100} \end{aligned}$$

100 hundredths is same as 1 unit.

$$\begin{aligned} \text{(d)} \quad & \left(\frac{1534}{100} \right) + \left(\frac{268}{100} \right) \\ &= \frac{1802}{100} \\ &= \frac{1800}{100} + \frac{2}{100} \\ &= 18 \frac{2}{100} \end{aligned}$$

15 is the same as 1500 hundredths and 2 is the same as 200 hundredths.

❓ What is the difference: $25 \frac{9}{10} - 6 \frac{4}{10} \frac{7}{100}$?

One way to solve this is as follows:

$$\begin{array}{r} 25 \frac{9}{10} \\ - 6 \frac{4}{10} \frac{7}{100} \\ \hline \end{array} \longrightarrow \begin{array}{r} 25 \frac{8}{10} \frac{10}{100} \\ - 6 \frac{4}{10} \frac{7}{100} \\ \hline \end{array} \longrightarrow \begin{array}{r} 25 \frac{8}{10} \frac{10}{100} \\ - 6 \frac{4}{10} \frac{7}{100} \\ \hline = 19 \frac{4}{10} \frac{3}{100} \end{array}$$

- ? Solve this by converting to hundredths.



What is the difference $15\frac{3}{10}\frac{4}{100} - 2\frac{6}{10}\frac{8}{100}$?

One way to solve this is as follows:

$$\begin{array}{r}
 15\frac{3}{10}\frac{4}{100} \\
 - 2\frac{6}{10}\frac{8}{100} \\
 \hline
 \end{array}
 \qquad
 \begin{array}{r}
 15\frac{2}{10}\frac{14}{100} \\
 - 2\frac{6}{10}\frac{8}{100} \\
 \hline
 \end{array}
 \qquad
 \begin{array}{r}
 14\frac{12}{10}\frac{14}{100} \\
 - 2\frac{6}{10}\frac{8}{100} \\
 \hline
 = 12\frac{6}{10}\frac{6}{100}
 \end{array}$$

Observe the subtraction done below for $653 - 268$. Do you see any similarities with the methods shown above?



$$\begin{aligned}
 & (600 + 50 + 3) - (200 + 60 + 8) \\
 &= (600 - 200) + (50 - 60) + (3 - 8) \\
 &= (600 - 200) + (40 - 60) + (13 - 8) \\
 &= (600 - 200) + (40 - 60) + 5 \\
 &= (500 - 200) + (140 - 60) + 5 \\
 &= 300 + 80 + 5 \\
 &= 385
 \end{aligned}$$

- ? **Figure it Out**

Find the sums and differences:

(a) $\frac{3}{10} + 3\frac{4}{100}$

(b) $9\frac{5}{10}\frac{7}{100} + 2\frac{1}{10}\frac{3}{100}$

(c) $15\frac{6}{10}\frac{4}{100} + 14\frac{3}{10}\frac{6}{100}$

(d) $7\frac{7}{100} - 4\frac{4}{100}$

(e) $8\frac{6}{100} - 5\frac{3}{100}$

(f) $12\frac{6}{100}\frac{2}{100} - \frac{9}{10}\frac{9}{100}$

3.4 Decimal Place Value

You may have noticed that whenever we need to measure something more accurately, we split a part into 10 (smaller) equal parts — we split a unit into 10 one-tenths and then split each one-tenth into 10, one-hundredths and then we use these smaller parts to measure.

- ❓ Can we not split a unit into 4 equal parts, 5 equal parts, 8 equal parts, or any other number of equal parts instead?

Yes, we can. The example below compares how the same length is represented when the unit is split into 10 equal parts and when the unit is split into 4 equal parts.

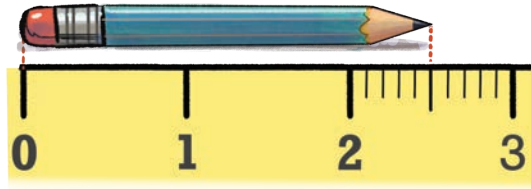

If an even more precise measure is needed, each quarter can further be split into four equal parts. Each part then measures $\frac{1}{16}$ of a unit, i.e., 16 such parts make 1 unit.

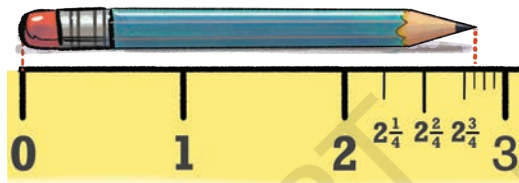
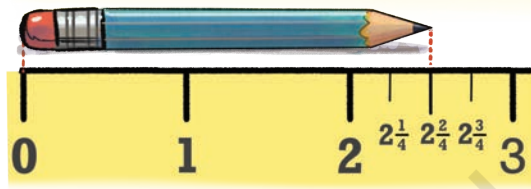

- ❓ Then why split a unit into 10 parts every time?

The reason is the special role that 10 plays in the Indian place value system. For a whole number written in the Indian place value system — for example, 281 — the place value of 2 is hundreds (100), that of 8 is tens (10), and that of 1 is one (1). Each place value is 10 times bigger than the one immediately to its right. Equivalently, each place value is 10 times smaller than the one immediately to its left:

- 10 ones make 1 ten,
- 10 tens make 1 hundred,
- 10 hundreds make 1 thousand, and so on.

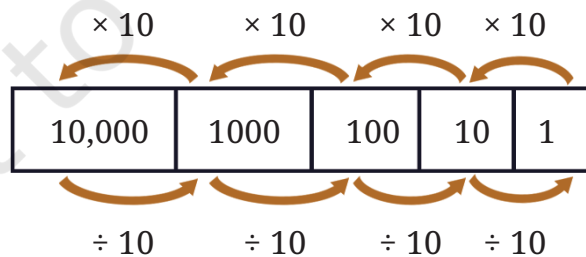

In order to extend this system of writing numbers to quantities smaller than one, we divide one into 10 equal parts. What does this give? It gives one-tenth. Further dividing it into 10 parts gives one-hundredth, and so on.

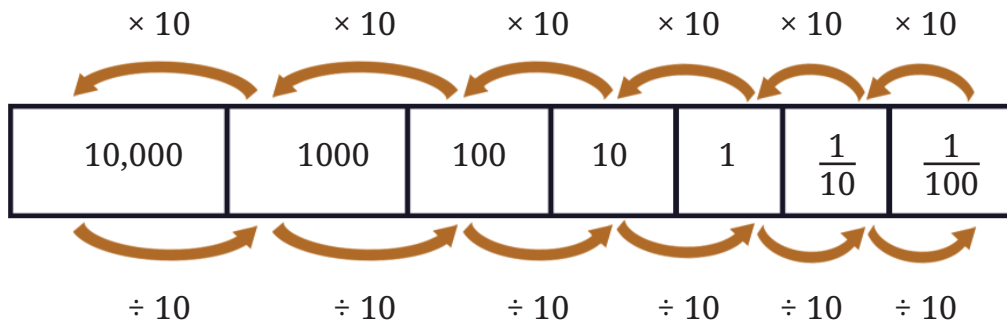

Can we extend this further?

What will the fraction be when $\frac{1}{100}$ is split into 10 equal parts?

It will be $\frac{1}{1000}$, i.e., a thousand such parts make up a unit.

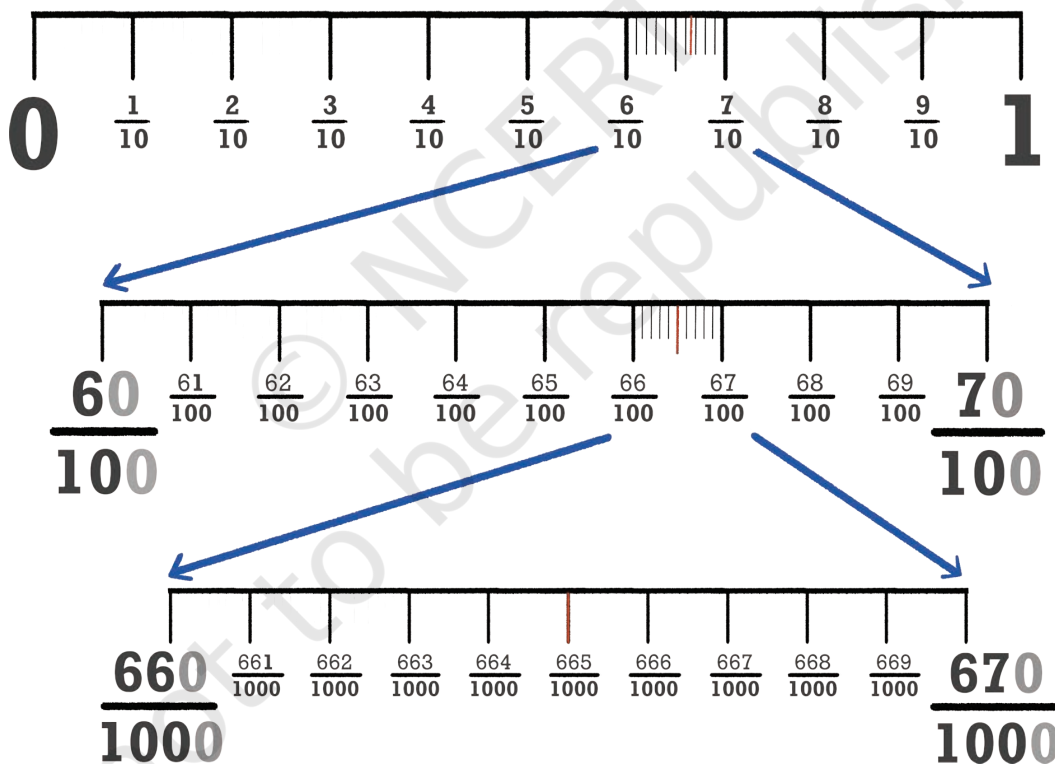

Just as when we extend to the left of 10,000, we get bigger place values at each step, we can also extend to the right of $\frac{1}{1000}$, getting smaller place values at each step.

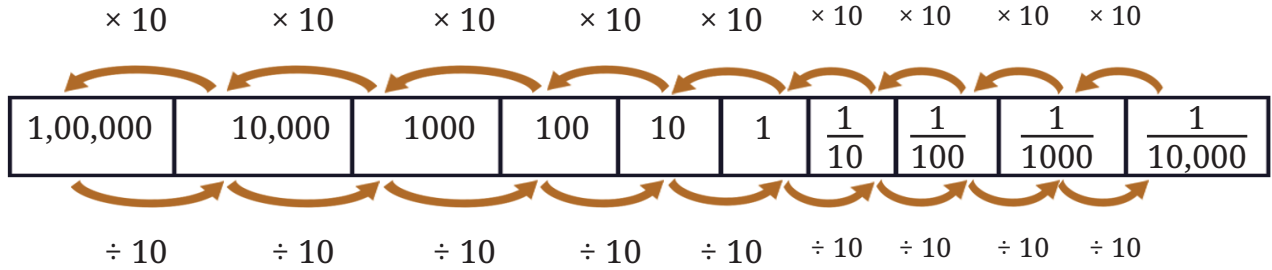

This way of writing numbers is called the “decimal system” since it is based on the number 10; “decem” means ten in Latin, which in turn is cognate to the Sanskrit *daśha* meaning 10, with similar words for 10 occurring across many Indian languages including Odia, Konkani, Marathi, Gujarati, Hindi, Kashmiri, Bodo, and Assamese. We shall learn about other ways of writing numbers in later grades.

How Big?

We already know that a hundred 10s make 1000, and a hundred 100s make 10000.

- ① We can ask similar questions about fractional parts:
- How many thousandths make one unit?
 - How many thousandths make one tenth?
 - How many thousandths make one hundredth?
 - How many tenths make one ten?
 - How many hundredths make one ten?
- ② Make a few more questions of this kind and answer them.

Notation, Writing and Reading of Numbers

We have been writing numbers in a particular way, say 456, instead of writing them as 4×100 (4 hundreds) + 5×10 (5 tens) + 6×1 (6 ones). Similarly, can we skip writing tenths and hundredths?

Can the quantity $4\frac{2}{10}$ be written as 42 (skipping the $\frac{1}{10}$ in $2 \times \frac{1}{10}$)?



If yes, how would we know if 42 means 4 tens and 2 units or it means 4 units and 2 tenths?

Similarly, 705 could mean:

- 7 hundreds, and 0 tens and 5 ones ($700 + 0 + 5$)
- 7 tens and 0 units and 5 tenths ($70 + 0 + \frac{5}{10}$)
- 7 units and 0 tenths and 5 hundredths ($7 + \frac{0}{10} + \frac{5}{100}$)

Since these are different quantities, we need to have distinct ways of writing them.

To identify the place value where integers end and the fractional parts start, we use a point or period (‘.’) as a separator, called a **decimal point**.

The above quantities in decimal notation are then:

Quantity	Decimal Notation
7 hundreds and 5 ones (700 + 0 + 5)	705
7 tens and 5 tenths $(70 + 0 + \frac{5}{10})$	70.5
7 units and 5 hundredths $(7 + 0 + \frac{5}{100})$	7.05

These numbers, when shown through place value, are as follows:

Decimal number	Hundreds	Tens	Units	• Tenths	Hundredths
705	7×100	0×10	5×1	•	
70.5		7×10	0×1	• $5 \times \frac{1}{10}$	
7.05			7×1	• $0 \times \frac{1}{10}$	$5 \times \frac{1}{100}$

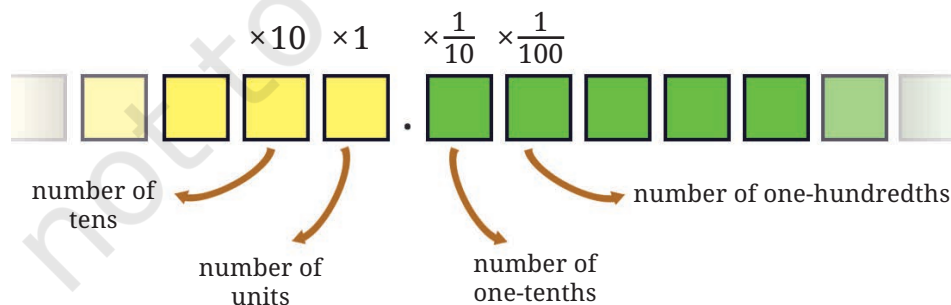

Thus decimal notation is a natural extension of the Indian place value system to numbers also having fractional parts. Just as 705 means $7 \times 100 + 5 \times 1$, the number 70.5 means $7 \times 10 + 5 \times \frac{1}{10}$, and 7.05 means $7 \times 1 + 5 \times \frac{1}{100}$.

We have seen how to write numbers using the decimal point ('.'). But how do we read/say these numbers?

We know that 705 is read as **seven hundred and five**.

70.5 is read as **seventy point five**, short for **seventy and five-tenths**.

7.05 is read as **seven point zero five**, short for **seven and five hundredths**.

0.274 is read as **zero point two seven four**. We don't read it as **zero point two hundred and seventy four** as 0.274 means **2 one-tenths and 7 one-hundredths and 4 one-thousandths**.

? Make a place value table similar to the one above. Write each quantity in decimal form and in terms of place value, and read the number:

- (a) 2 ones, 3 tenths and 5 hundredths
- (b) 1 ten and 5 tenths
- (c) 4 ones and 6 hundredths
- (d) 1 hundred, 1 one and 1 hundredth
- (e) $\frac{8}{100}$ and $\frac{9}{10}$
- (f) $\frac{5}{100}$
- (g) $\frac{1}{10}$
- (h) $2\frac{1}{100}$, $4\frac{1}{10}$ and $7\frac{7}{1000}$

In the chapter on large numbers, we learned how to write 23 hundreds.

$$23 \text{ hundreds} = 23 \times 100 = 2000 + 300 = 2300.$$

Thousands	Hundreds	Tens	Units
	23		
2	3	0	0

Similarly, 23 tens would be:

$$23 \text{ tens} = 23 \times 10 = 200 + 30 = 230.$$

Thousands	Hundreds	Tens	Units
		23	
	2	3	0

- ? How can we write 234 tenths in decimal form?

$$\begin{aligned}
 234 \text{ tenths} &= \frac{234}{10} \\
 &= \frac{200}{10} + \frac{30}{10} + \frac{4}{10} \\
 &= 20 + 3 + \frac{4}{10} \\
 &= 23.4.
 \end{aligned}$$

Hundreds	Tens	Units	Tenths	Hundredths
			234	
	2	3	• 4	

- ? Write these quantities in decimal form: (a) 234 hundredths, (b) 105 tenths.

3.5 Units of Measurement

Length Conversion

We have been using a scale to measure length for a few years. We already know that 1 cm = 10 mm (millimeters).

- ? How many cm is 1 mm?

$$1 \text{ mm} = \frac{1}{10} \text{ cm} = 0.1 \text{ cm (i.e., one-tenth of a cm).}$$

- ? How many cm is (a) 5 mm? (b) 12 mm?

$$\begin{aligned}
 5 \text{ mm} &= \frac{5}{10} \text{ cm} = 0.5 \text{ cm} \\
 12 \text{ mm} &= 10 \text{ mm} + 2 \text{ mm} \\
 &= 1 \text{ cm} + \frac{2}{10} \text{ cm} \\
 &= 1.2 \text{ cm}.
 \end{aligned}$$

How many mm is 5.6 cm? Since each cm has 10 mm, 5.6 cm (5 cm + 0.6 cm) is 56 mm.

❓ Fill in the blanks below (mm \leftrightarrow cm)

12 mm = 1.2 cm	56 mm = 5.6 cm	70 mm = _____
_____ = 0.9 cm	134 mm = _____	_____ = 203.6 cm

The illustration below shows how small some things are! Try taking an approximate measurement of each.

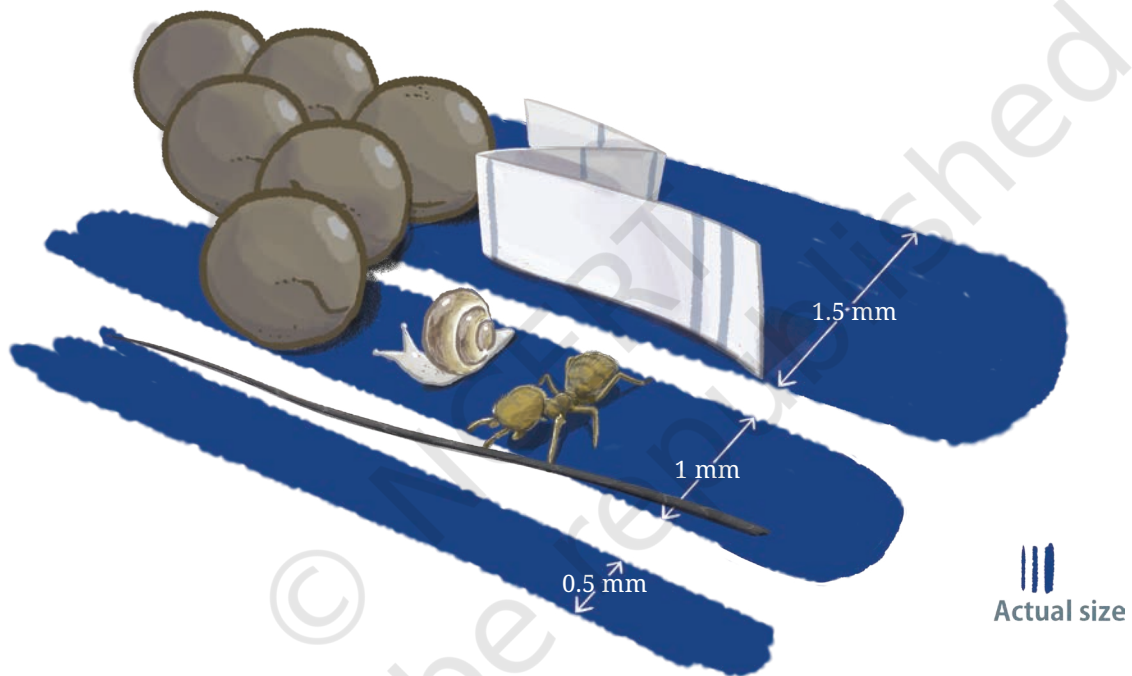

- The three blue stripes represent the typical relative sizes of pen strokes: fine stroke, medium stroke, and bold stroke.
- A human hair is about 0.1 mm in thickness.
- The thickness of a newspaper can range from 0.05 to 0.08 mm.
- Mustard seeds have a thickness of 1 – 2 mm.
- The smallest ant species discovered so far, Carabera Bruni, has a total length of 0.8 – 1 mm. They are found in Sri Lanka and China.
- The smallest land snail species discovered so far, Acmea Nana, has a shell diameter of 0.7 mm. They are found in Malaysia.

We also know that 1 m = 100 cm. Based on this, we can say that

$$1 \text{ cm} = \frac{1}{100} \text{ m} = 0.01 \text{ m.}$$

- ? How many m is (a) 10 cm? (b) 15 cm?

$$10 \text{ cm} = \frac{1}{10} \text{ m} = 0.1 \text{ m}$$

Since each cm is one-hundredth of a meter, 15 cm can be written as

$$\begin{aligned} 15 \text{ cm} &= \frac{15}{100} \text{ m} \\ &= \frac{10}{100} \text{ m} + \frac{5}{100} \text{ m} \\ &= \frac{1}{10} \text{ m} + \frac{5}{100} \text{ m} \\ &= 0.15 \text{ m}. \end{aligned}$$

- ? Fill in the blanks below (cm \leftrightarrow m):

36 cm = _____	50 cm = _____	_____ = 0.89 m
4 cm = _____	325 cm = _____	_____ = 2.07 m

- ? How many mm does 1 meter have?

- ? Can we write $1 \text{ mm} = \frac{1}{1000} \text{ m}$?

Here, we have some more interesting facts about small things in nature!

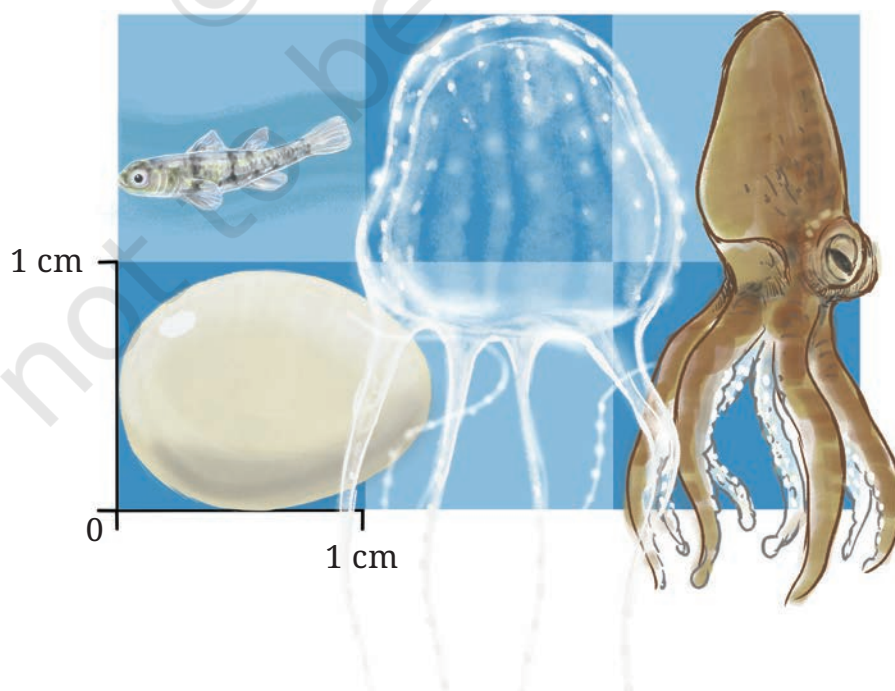

- The egg of a hummingbird typically is 1.3 cm long and 0.9 cm wide.
- The Philippine Goby is about 0.9 cm long. It can be found in the Philippines and other Southeast Asian countries.
- The smallest known jellyfish, Irukandji, has a belly size of 0.5 – 2.5 cm. Its tentacles can be as long as 1 m. They are found in Australia. Its venom can be fatal to humans.
- The Wolfi octopus, also known as the Star-sucker Pygmy Octopus, is the smallest known octopus in the world. Their typical size is around 1 – 2.5 cm and they weigh less than 1 gm. They are found in the Pacific Ocean.

Weight Conversion

Let us look at kilograms (kg). We know that 1 kg = 1000 gram (g). We can say that

$$1 \text{ g} = \frac{1}{1000} \text{ kg} = 0.001 \text{ kg}.$$

- ❓ How many kilograms is 5 g?

$$5 \text{ g} = \frac{5}{1000} \text{ kg} = 0.005 \text{ kg}.$$

- ❓ How many kilograms is 10 g?

$$10 \text{ g} = \frac{10}{1000} \text{ kg} = \frac{1}{100} \text{ kg} = 0.010 \text{ kg}.$$

As each gram is one-thousandth of a kg, 254 g can be written as

$$\begin{aligned} 254 \text{ g} &= \frac{254}{1000} \text{ kg} \\ &= \left(\frac{200}{1000} + \frac{50}{1000} + \frac{4}{1000} \right) \text{ kg} \\ &= \left(\frac{2}{10} + \frac{5}{100} + \frac{4}{1000} \right) \text{ kg} \\ &= 0.254 \text{ kg}. \end{aligned}$$

- ❓ Fill in the blanks below (g ↔ kg)

465 g = _____	68 g = _____	1560 g = _____
704 g = _____	_____ = 0.56 kg	_____ = 2.5 kg

Look at the picture below showing different quantities of rice. Starting from the 1g heap, subsequent heaps can be found that are 10 times heavier than the previous heap/packets. The combined weight of rice in this picture is 11.111 kg.



Also,

$$1 \text{ gram} = 1000 \text{ milligrams (mg)}. \text{ So, } 1 \text{ mg} = \frac{1}{1000} \text{ g} = 0.001 \text{ g}.$$

Rupee – Paise conversion

You may have heard of ‘paise’. 100 paise is equal to 1 rupee. As we have coins and notes for rupees, coins for paise were also used commonly until recently. There were coins for 1 paise, 2 paise, 3 paise, 5 paise, 10 paise, 20 paise, 25 paise, and 50 paise. All denominations of 25 paise and less were removed from use in the year 2011. But we still see paise in bills, account statements, etc.

$$1 \text{ rupee} = 100 \text{ paise}$$

$$1 \text{ paise} = \frac{1}{100} \text{ rupee} = 0.01 \text{ rupee}$$

As each paise is one-hundredth of a rupee,

$$75 \text{ paise} = \frac{75}{100} \text{ rupee}$$



$$= \left(\frac{70}{100} + \frac{5}{100} \right) \text{ rupee}$$

$$= \left(\frac{7}{10} + \frac{5}{100} \right) \text{ rupee}$$

$$= 0.75 \text{ rupee.}$$

? Fill in the blanks below (rupee \leftrightarrow paise)

10 p = _____	_____ p = ₹ 0.05	_____ p = ₹ 0.36
_____ = ₹ 0.50	99 p = _____	250 p = _____

During the 1970s, a masala dosa cost just 50 paise, one could buy a banana for 20-25 paise, a handful of peppermints were available for 2 paise or 3 paise, and a kg of rice cost ₹2.45.

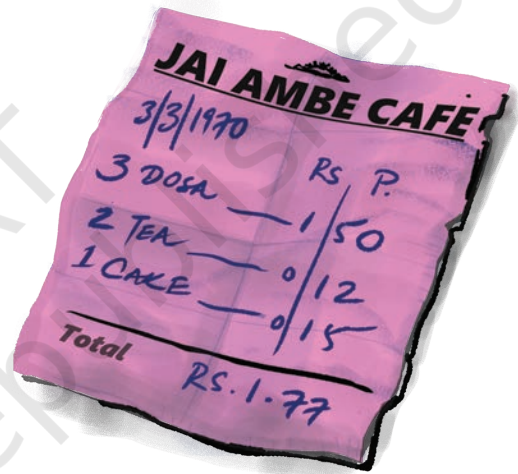

Discuss with adults at home/school the prices of different products and services during their childhood. Try to find old coins and stamps.



3.6 Locating and Comparing Decimals

Let us consider the decimal number 1.4. It is equal to 1 unit and 4 tenths. This means that the unit between 1 and 2 is divided into 10

equal parts, and 4 such parts are taken. Hence, 1.4 lies between 1 and 2. Draw the number line and divide the unit between 1 and 2 into 10 equal parts. Take the fourth part, and we have 1.4 on the number line.

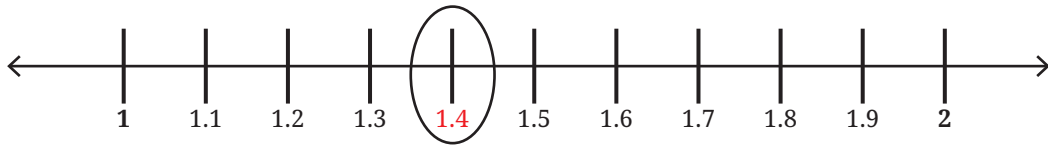

- ① Name all the divisions between 1 and 1.1 on the number line.



- ② Identify and write the decimal numbers against the letters.

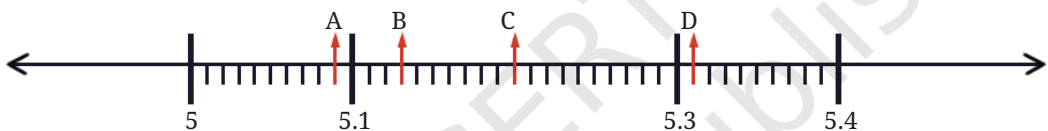

There is Zero Dilemma!

- ③ Sonu says that 0.2 can also be written as 0.20, 0.200; Zara thinks that putting zeros on the right side may alter the value of the decimal number. What do you think?

We can figure this out by looking at the quantities these numbers represent using place value.

Decimal number	Units	Tenths	Hundredths	Thousandths
0.2	0	2		
0.20	0	2	0	
0.200	0	2	0	0
0.02	0	0	2	
0.002	0	0	0	2

We can see that 0.2, 0.20, and 0.200 are all equal as they represent the same quantity, i.e., 2 tenths. But 0.2, 0.02, and 0.002 are different.

- ② Can you tell which of these is the smallest and which is the largest?
- ② Which of these are the same: 4.5, 4.05, 0.405, 4.050, 4.50, 4.005, 04.50?

Observe the number lines in Figure (a) below. At each level, a particular segment of the number line is magnified to locate the number 4.185.

- ② Identify the decimal number in the last number line in Figure (b) denoted by ‘?’.

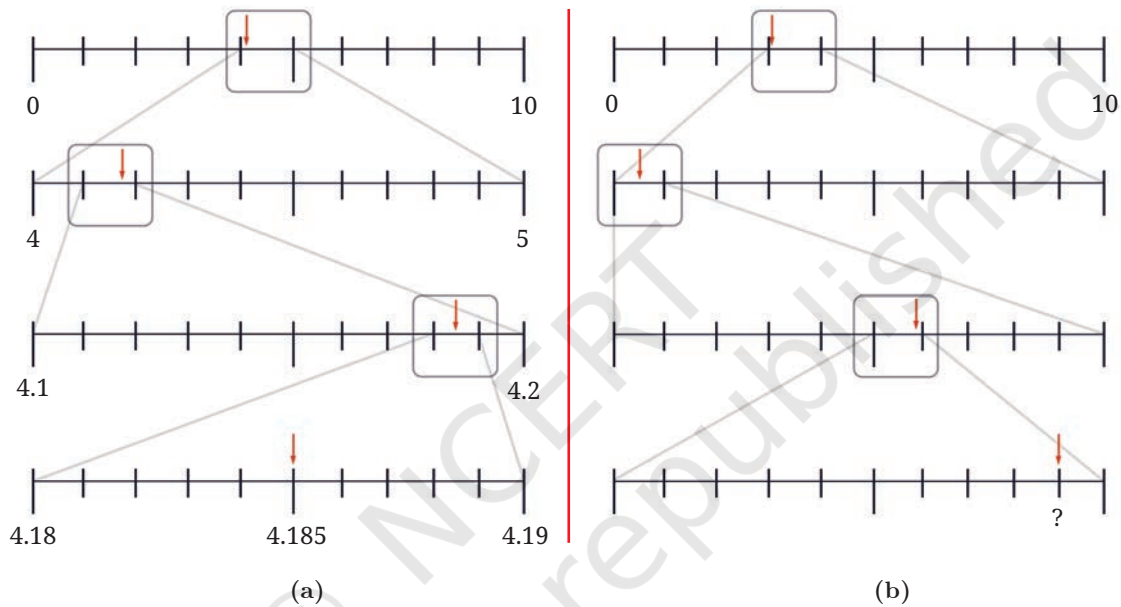

- ② Make such number lines for the decimal numbers: (a) 9.876 (b) 0.407.
- ② In the number line shown below, what decimal numbers do the boxes labelled ‘a’, ‘b’, and ‘c’ denote?

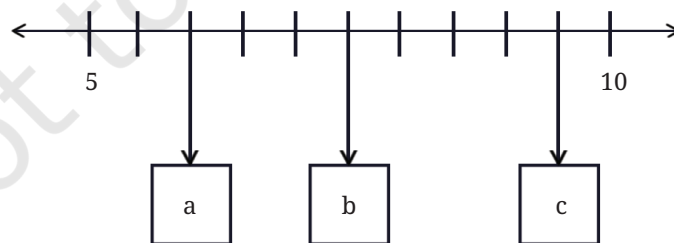

The box with ‘b’ corresponds to the decimal number 7.5; are you able to see how? There are 5 units between 5 and 10, divided into 10 equal parts. Hence, every 2 divisions make a unit, and so every division is $\frac{1}{2}$ unit. What numbers do ‘a’ and ‘c’ denote?

? Using similar reasoning find out the decimal numbers in the boxes below.

? Which is larger: 6.456 or 6.465?

To answer this, we can use the number line to locate both decimal numbers and show which is larger.

This can also be done by comparing the corresponding digits at each place value, as we do with whole numbers.

This comparison is visualised step by step below. Note that the visualisation below is not to scale.

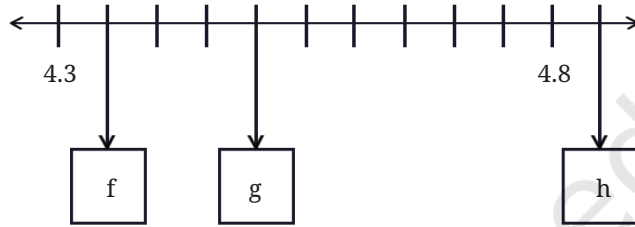
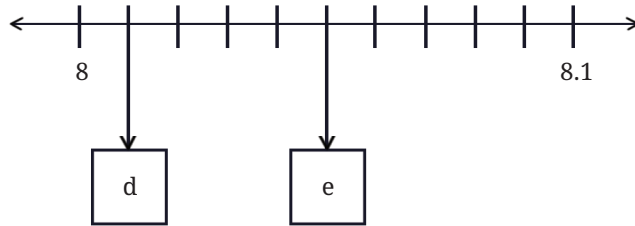

	<p>Both numbers have 6 units.</p>
	<p>Both numbers have 6 units and 4 tenths.</p>
	<p>Both numbers have 6 units and 4 tenths, but the first number has only 5 hundredths, whereas the second number has 6 hundredths.</p>

We start by comparing the most significant digits (digits with the highest place value) of the two numbers. If the digits are the same, we compare the next smaller place value. We keep going till we find a position where the digits are not equal. The number with the larger digit at this position is the greater of the two.

- ① Why can we stop comparing at this point? Can we be sure that whatever digits are there after this will not affect our conclusion?



Which decimal number is greater?

- (a) 1.23 or 1.32
- (b) 3.81 or 13.800
- (c) 1.009 or 1.090

Closest Decimals

Consider the decimal numbers 0.9, 1.1, 1.01, and 1.11. Identify the decimal number that is closest to 1.

Let us compare the decimal numbers. Arranging these in ascending order, we get $0.9 < 1 < 1.01 < 1.1 < 1.11$. Among the neighbours of 1, 1.01 is $\frac{1}{100}$ away from 1 whereas 0.9 is $\frac{10}{100}$ away from 1. Therefore, 1.01 is closest to 1.

- ① Which of the above is closest to 1.09?
- ② Which among these is closest to 4: 3.56, 3.65, 3.099?
- ③ Which among these is closest to 1: 0.8, 0.69, 1.08?
- ④ In each case below use the digits 4, 1, 8, 2, and 5 exactly once and try to make a decimal number as close as possible to 25.



.

.

.

3.7 Addition and Subtraction of Decimals

- ❓ Priya requires 2.7 m of cloth for her skirt, and Shylaja requires 3.5m for her kurti. What is the total quantity of cloth needed?

We have to find the sum of $2.7\text{m} + 3.5\text{m}$.

Earlier, we saw how to add $2\frac{7}{10} + 3\frac{5}{10}$ (also shown below). Can you carry out the same addition using decimal notation? It is shown below.

Share your observations.

The total quantity of cloth needed is 6.2 m.

$$\begin{array}{r}
 2\frac{7}{10} \\
 + 3\frac{5}{10} \\
 \hline
 = 5\frac{12}{10} \\
 = 6\frac{2}{10}
 \end{array}
 \qquad
 \begin{array}{r}
 \overset{1}{2.7} \\
 + 3.5 \\
 \hline
 = 6.2
 \end{array}$$

- ❓ How much longer is Shylaja's cloth compared to Priya's?

We have to find the difference of $3.5\text{m} - 2.7\text{m}$. Again, observe how the differences $3\frac{5}{10} - 2\frac{7}{10}$ and $3.5\text{m} - 2.7\text{m}$ are computed.

$$\begin{array}{r}
 3\frac{5}{10} \longrightarrow 2\frac{15}{10} \\
 - 2\frac{7}{10} \\
 \hline
 = 0\frac{8}{10}
 \end{array}
 \qquad
 \begin{array}{r}
 3.5 \longrightarrow \overset{2}{\cancel{3}}.\overset{1}{5} \\
 - 2.7 \\
 \hline
 = 0.8
 \end{array}$$

As you can see, the standard procedure for adding and subtracting whole numbers can be used to add and subtract decimals.

A detailed view of the underlying place value calculation is shown below for the sum $75.345 + 86.691$. Its compact form is shown next to it.

1×100	1×10 7×10	1×1 5×1	$1 \times \frac{1}{10}$ $3 \times \frac{1}{10}$	$4 \times \frac{1}{100}$	$5 \times \frac{1}{1000}$	
+	8×10	6×1	$6 \times \frac{1}{10}$	$9 \times \frac{1}{100}$	$1 \times \frac{1}{1000}$	$\begin{array}{r} 111 \\ 75.345 \\ +86.691 \\ \hline =162.036 \end{array}$
= 1×100	16×10	12×1	$10 \times \frac{1}{10}$	$13 \times \frac{1}{100}$	$6 \times \frac{1}{1000}$	

② Write the detailed place value computation for $84.691 - 77.345$, and its compact form.



② **Figure it Out**

1. Find the sums

- | | |
|--------------------|---------------------|
| (a) $5.3 + 2.6$ | (b) $18 + 8.8$ |
| (c) $2.15 + 5.26$ | (d) $9.01 + 9.10$ |
| (e) $29.19 + 9.91$ | (f) $0.934 + 0.6$ |
| (g) $0.75 + 0.03$ | (h) $6.236 + 0.487$ |

2. Find the differences

- | | |
|------------------|---------------------|
| (a) $5.6 - 2.3$ | (b) $18 - 8.8$ |
| (c) $10.4 - 4.5$ | (d) $17 - 16.198$ |
| (e) $17 - 0.05$ | (f) $34.505 - 18.1$ |
| (g) $9.9 - 9.09$ | (h) $6.236 - 0.487$ |

Decimal Sequences

Observe this sequence of decimal numbers and identify the change after each term.

4.4, 4.8, 5.2, 5.6, 6.0, ...

We can see that 0.4 is being added to a term to get the next term.

② Continue this sequence and write the next 3 terms.

- ? Similarly, identify the change and write the next 3 terms for each sequence given below. Try to do this computation mentally.

- | | |
|------------------------------|------------------------------|
| (a) 4.4, 4.45, 4.5, ... | (b) 25.75, 26.25, 26.75, ... |
| (c) 10.56, 10.67, 10.78, ... | (d) 13.5, 16, 18.5, ... |
| (e) 8.5, 9.4, 10.3, ... | (f) 5, 4.95, 4.90, ... |
| (g) 12.45, 11.95, 11.45, ... | (h) 36.5, 33, 29.5, ... |

- ? Make your own sequences and challenge your classmates to extend the pattern.

Estimating Sums and Differences

Sonu has observed sums and differences of decimal numbers and says, “If we add two decimal numbers, then the sum will always be greater than the sum of their whole number parts. Also, the sum will always be less than 2 more than the sum of their whole number parts.”

Let us use an example to understand what his claim means:

If the two numbers to be added are 25.936 and 8.202, the claim is that their sum will be greater than $25 + 8$ (whole number parts) and will be less than $25 + 1 + 8 + 1$.

- ? What do you think about this claim? Verify if this is true for these numbers. Will it work for any 2 decimal numbers?



- ? What about for the sum of 25.93603259 and 8.202?

- ? Similarly, come up with a way to narrow down the range of whole numbers within which the difference of two decimal numbers will lie.



Note to the Teacher: Estimating the result before computing may help in identifying if a mistake happens with the calculation.

3.8 More on the Decimal System

Decimal and Measurement Disasters

Decimal point and unit conversion mistakes may seem minor sometimes but they can lead to serious problems. Here are some actual incidents in which such errors caused major issues.

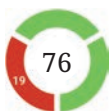

- In 2013, the finance office of Amsterdam City Council (Netherlands) mistakenly sent out €188 million in housing benefits instead of the intended €1.8 million due to a programming error that processed payments in euro cents instead of euros. (1 euro-cent = 1/100 euro).
- In 1983, a decimal error nearly caused a disaster for an Air Canada Boeing 767. The ground staff miscalculated the fuel, loading 22,300 pounds instead of kilograms—about half of what was needed (1 pound ~ 0.453 kg). The plane ran out of fuel mid-air, forcing the pilots to make an emergency landing at an abandoned airfield. Fortunately, everyone survived.

Several incidents have occurred due to incorrect reading of decimal numbers while giving medication. For example, reading 0.05 mg as 0.5 mg can lead to using a medicine 10 times more than the prescribed quantity. It is therefore important to pay attention to units and the location of the decimal point.

Deceptive Decimal Notation

Sarayu gets a message: “The bus will reach the station 4.5 hours post noon.” When will the bus reach the station: 4:05 p.m., 4:50 p.m., 4:25 p.m.?

None of these! Here, 0.5 hours means splitting an hour into 10 equal parts and taking 5 parts out of it. Each part will be 6 minutes (60 minutes/10) long. 5 such parts make 30 minutes. So, the bus will reach the station at 4:30.

Here is a short-story of a decimal mishap: A girl measures the width of an opening as 2 ft 5 inches but conveys to the carpenter to make a door 2.5 ft wide. The carpenter makes a door of width 2 ft 6 inches (since 1 ft = 12 inches, 0.5 ft = 6 inches), and it wouldn't close fully.

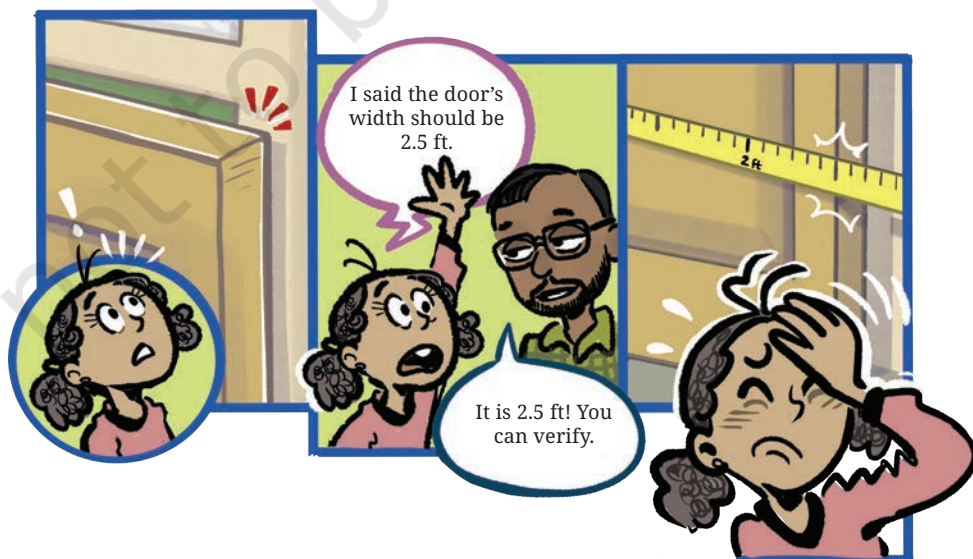

If you watch cricket, you might have noticed decimal-looking numbers like ‘Overs left: 5.5’. Does this mean 5 overs and 5 balls or 5 overs and 3 balls? Here, 5.5 overs means $5\frac{5}{6}$ overs (as 1 over = 6 balls), i.e., 5 overs and 5 balls.

- ❓ Where else can we see such ‘non-decimals’ with a decimal-like notation?



A Pinch of History – Decimal Notation Over Time

Decimal fractions (i.e., fractions with denominators like $\frac{1}{10}$, $\frac{1}{100}$, $\frac{1}{1000}$, and so on) are used in the works of a number of ancient Indian astronomers and mathematicians, including in the important 8th century works of Śhrīdharāchārya on arithmetic and algebra. Decimal notation, in essentially its modern form, was described in detail in *Kitāb al-Fuṣūl fī al-Ḥisāb al Hindī* (The Book of Chapters on Indian Arithmetic) by Abūl Ḥassan al-Uqlīdisī, an Arab mathematician, in around 950 CE. He represented the number 0.059375 as 0059375.

In the 15th century, to separate whole numbers from fractional parts, a number of different notations were used:

- a vertical mark on the last digit of the whole number part (as shown above),
- use of different colours and
- a numerical superscript giving the number of fractional decimal places (0.36 would be written as 36^2).

In the 16th century, John Napier, a Scottish mathematician, and Christopher Clavius, a German mathematician, used the point/period (‘.’) to separate the whole number and the fractional parts, while François Viète, a French mathematician, used the comma (‘,’) instead.

Currently, several countries use the comma to separate the integer part and the fractional part. In these countries, the number 1,000.5 is written as 1 000,5 (space as a thousand separator). But the decimal point has endured as the most popular notation for writing numbers having fractional parts in the Indian place value system.

❓ Figure it Out

1. Convert the following fractions into decimals:

(a) $\frac{5}{100}$

(b) $\frac{16}{1000}$

(c) $\frac{12}{10}$

(d) $\frac{254}{1000}$

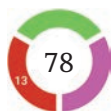

2. Convert the following decimals into a sum of tenths, hundredths and thousandths:

- (a) 0.34 (b) 1.02 (c) 0.8 (d) 0.362

3. What decimal number does each letter represent in the number line below?

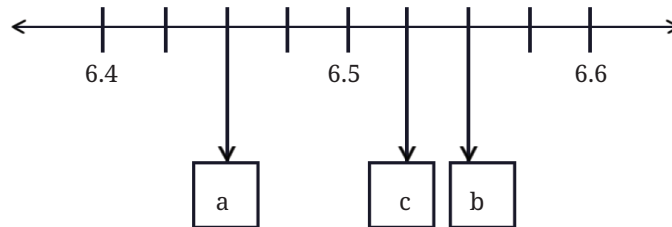

4. Arrange the following quantities in descending order:

- (a) 11.01, 1.011, 1.101, 11.10, 1.01
 (b) 2.567, 2.675, 2.768, 2.499, 2.698
 (c) 4.678 g, 4.595 g, 4.600 g, 4.656 g, 4.666 g
 (d) 33.13 m, 33.31 m, 33.133 m, 33.331 m, 33.313 m

5. Using the digits 1, 4, 0, 8, and 6 make:

- (a) the decimal number closest to 30
 (b) the smallest possible decimal number between 100 and 1000.

6. Will a decimal number with more digits be greater than a decimal number with fewer digits?

7. Mahi purchases 0.25 kg of beans, 0.3 kg of carrots, 0.5 kg of potatoes, 0.2 kg of capsicums, and 0.05 kg of ginger. Calculate the total weight of the items she bought.

8. Pinto supplies 3.79 L, 4.2 L, and 4.25 L of milk to a milk dairy in the first three days. In 6 days, he supplies 25 litres of milk. Find the total quantity of milk supplied to the dairy in the last three days.

9. Tinku weighed 35.75 kg in January and 34.50 kg in February. Has he gained or lost weight? How much is the change?

10. Extend the pattern: 5.5, 6.4, 6.39, 7.29, 7.28, 6.18, 6.17, ____, ____

11. How many millimeters make 1 kilometer?

12. Indian Railways offers optional travel insurance for passengers who book e-tickets. It costs 45 paise per passenger. If 1 lakh people opt for insurance in a day, what is the total insurance fee paid?

13. Which is greater?

- (a) $\frac{10}{1000}$ or $\frac{1}{10}$?

- (b) One-hundredth or 90 thousandths?
 (c) One-thousandth or 90 hundredths?
14. Write the decimal forms of the quantities mentioned (an example is given):
- (a) 87 ones, 5 tenths and 60 hundredths = 88.10
 (b) 12 tens and 12 tenths
 (c) 10 tens, 10 ones, 10 tenths, and 10 hundredths
 (d) 25 tens, 25 ones, 25 tenths, and 25 hundredths
15. Using each digit 0–9 not more than once, fill the boxes below so that the sum is closest to 10.5:



$$\begin{array}{r}
 \square . \square \square \square \\
 + \square . \square \square \square \\
 \hline
 \end{array}$$

16. Write the following fractions in decimal form:

(a) $\frac{1}{2}$

(b) $\frac{3}{2}$

(c) $\frac{1}{4}$

(d) $\frac{3}{4}$

(e) $\frac{1}{5}$

(f) $\frac{4}{5}$

SUMMARY

- We can split a unit into smaller parts to get more exact/accurate measurements.
- We extended the Indian place value system and saw that
 - » 1 unit = 10 one-tenths,
 - » 1 tenth = 10 one-hundredths,
 - » 1 hundredth = 10 one-thousandths,
 - » 10 one-hundredths = 1 tenth,
 - » 100 one-hundredths = 1 unit.
- A decimal point (‘.’) is used in the Indian place value system to separate the whole number part of a number from its fractional part.
- We also learnt how to compare decimal numbers, locate them on the number line, and perform addition and subtraction on them.

Chapter – 3

A Peek Beyond the Point

Page No. 47

② Write the measurements of the objects shown in the picture.

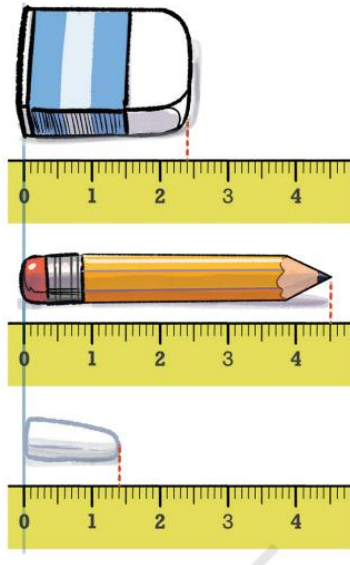

Ans:

Eraser $\rightarrow 2\frac{4}{10}$ cm, Pencil $\rightarrow 4\frac{5}{10}$ cm $\rightarrow 4\frac{1}{2}$ cm, Chalk $\rightarrow 1\frac{4}{10}$ cm

Page No. 49

② Arrange the lengths in increasing order:

(a) $\frac{9}{10}$

(b) $1\frac{7}{10}$

(c) $\frac{130}{10}$

(d) $13\frac{1}{10}$

(e) $10\frac{5}{10}$

(f) $7\frac{6}{10}$

(g) $6\frac{7}{10}$

(h) $\frac{4}{10}$

Ans:

$\frac{4}{10}$, $\frac{9}{10}$, $1\frac{7}{10}$, $6\frac{7}{10}$, $7\frac{6}{10}$, $10\frac{5}{10}$, $\frac{130}{10}$, $13\frac{1}{10}$

Page No. 50

- ② Arrange the following lengths in increasing order: $4\frac{1}{10}$, $\frac{4}{10}$, $\frac{41}{10}$, $41\frac{1}{10}$

Ans:

Increasing order: $\frac{4}{10}$, $\frac{41}{10} = 4\frac{1}{10}$, $41\frac{1}{10}$

Page No. 51

- ② The lengths of the body parts of a honeybee are given. Find its total length.

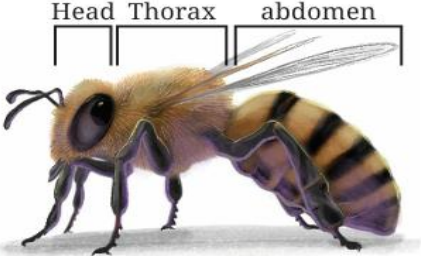
	<p>Head = $2\frac{3}{10}$ units</p> <p>Thorax = $5\frac{4}{10}$ units</p> <p>Abdomen = $7\frac{5}{10}$ units</p>
--	---

Ans: $15\frac{2}{10}$ units.

Page No. 52

- ② A Celestial Pearl Danio's length is $2\frac{4}{10}$ cm, and the length of a Philippine Goby is $\frac{9}{10}$ cm. What is the difference in their lengths?

Ans: $1\frac{5}{10}$ cm

- ② Observe the given sequences of numbers. Identify the change after each term and extend the pattern:

(a) $4, 4\frac{3}{10}, 4\frac{6}{10}$, _____, _____, _____, _____

(b) $8\frac{2}{10}, 8\frac{7}{10}, 9\frac{2}{10}$, _____, _____, _____, _____

(c) $7\frac{6}{10}, 8\frac{7}{10}$, _____, _____, _____, _____

(d) $5\frac{7}{10}, 5\frac{3}{10}, \quad \underline{\hspace{1cm}}, \underline{\hspace{1cm}}, \underline{\hspace{1cm}}, \underline{\hspace{1cm}}$

(e) $13\frac{5}{10}, 13, 12\frac{5}{10}, \quad \underline{\hspace{1cm}}, \underline{\hspace{1cm}}, \underline{\hspace{1cm}}, \underline{\hspace{1cm}}$

(f) $11\frac{5}{10}, 10\frac{4}{10}, 9\frac{3}{10}, \quad \underline{\hspace{1cm}}, \underline{\hspace{1cm}}, \underline{\hspace{1cm}}, \underline{\hspace{1cm}}$

Ans:

(a) $4, 4\frac{3}{10}, 4\frac{6}{10}, 4\frac{9}{10}, 5\frac{2}{10}, 5\frac{5}{10}, 5\frac{8}{10} \rightarrow$ increment of $\frac{3}{10}$ each time.

(b) $8\frac{2}{10}, 8\frac{7}{10}, 9\frac{2}{10}, 9\frac{7}{10}, 10\frac{2}{10}, 10\frac{7}{10}, 11\frac{2}{10} \rightarrow$ increment of $\frac{5}{10}$ each time.

(c) $7\frac{6}{10}, 8\frac{7}{10}, 9\frac{8}{10}, 10\frac{9}{10}, 12, 13\frac{1}{10} \rightarrow$ increment of $1 + \frac{1}{10}$

(d) $5\frac{7}{10}, 5\frac{3}{10}, 4\frac{9}{10}, 4\frac{5}{10}, 4\frac{1}{10}, 3\frac{7}{10} \rightarrow$ subtracting: $\frac{4}{10}$ each time

(e) $13\frac{5}{10}, 13, 12\frac{5}{10}, 12, 11\frac{5}{10}, 11, 10\frac{5}{10} \rightarrow$ decreasing by $\frac{5}{10}$

(f) $11\frac{5}{10}, 10\frac{4}{10}, 9\frac{3}{10}, 8\frac{2}{10}, 7\frac{1}{10}, 6 \rightarrow$ decreasing by $1\frac{1}{10}$

Page No. 53

❓ **How many one-hundredths make one-tenth? Can we also say that the length is 4 units and 45 one-hundredths?**

Ans: $\frac{1}{10} = \frac{10}{100}$

So, 10 one-hundredths make one-tenth.

Yes, we can write it $4 + \frac{45}{100} = 4$ units and 45 one-hundredths.

- ② Observe the figure below. Notice the markings and the corresponding lengths written in the boxes when measured from 0. Fill the lengths in the empty boxes.

Ans:

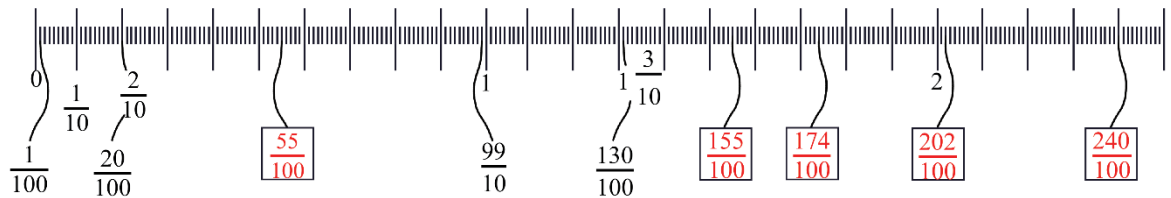

- ② For the lengths shown below write the measurements and read out the measures in words.

Ans:

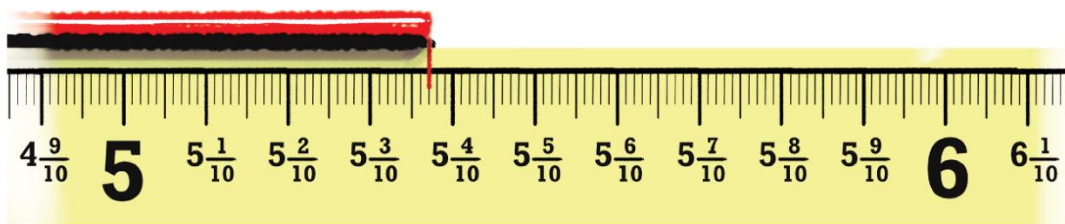

Measurement – $5\frac{37}{100}$

In words: Five and thirtyseven-hundredths.

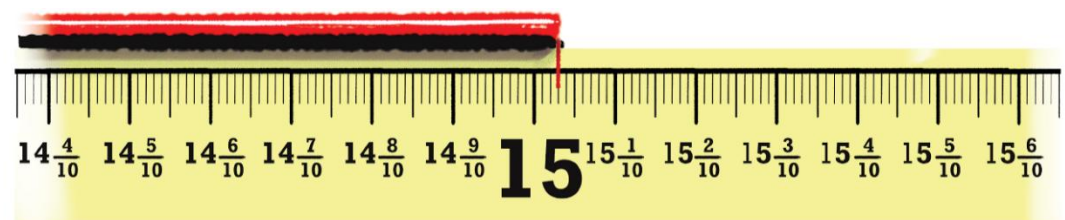

Measurement – $15\frac{3}{100}$

In words: Fifteen and three-hundredths.

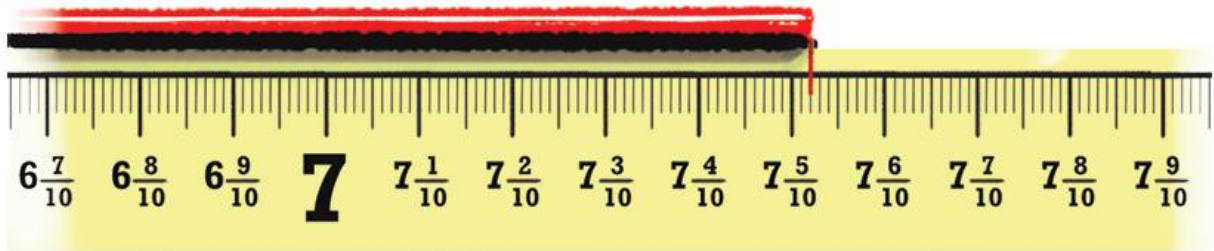

Measurement – $7\frac{52}{100}$

In words: Seven and fiftytwo-hundredths.

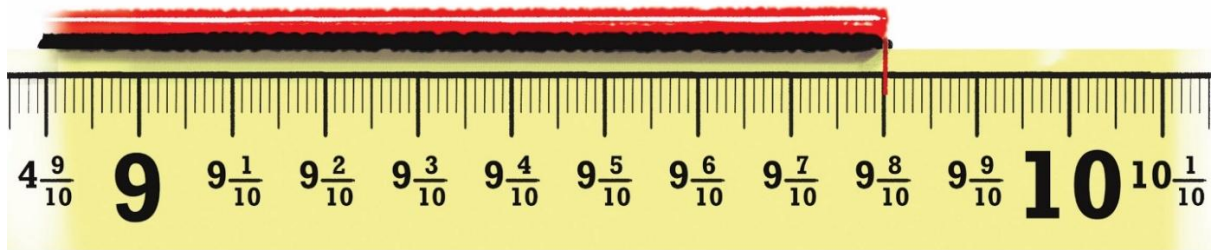

Measurement – $9\frac{80}{100}$

In words: Nine and eighty-hundredths.

❓ In each group, identify the longest and the shortest lengths. Mark each length on the scale.

Ans:

(a) $\frac{3}{10}$, $\frac{3}{100}$, $\frac{33}{100}$

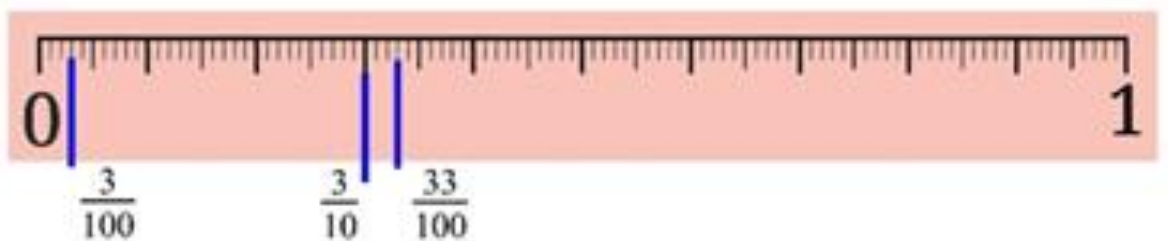

(b) $3\frac{1}{10}, \frac{30}{10}, 1\frac{3}{10}$

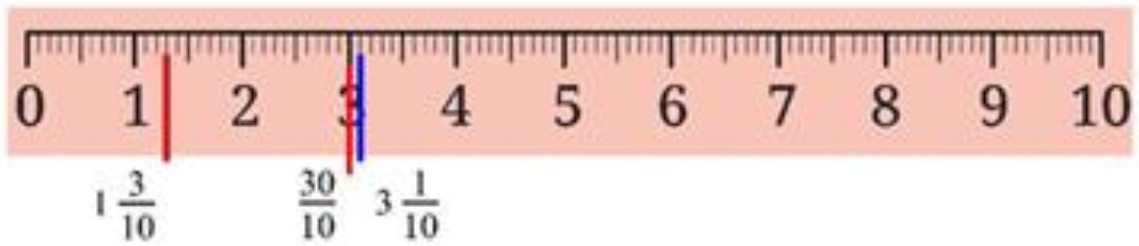

(c) $\frac{45}{100}, \frac{54}{100}, \frac{5}{10}, \frac{4}{10}$

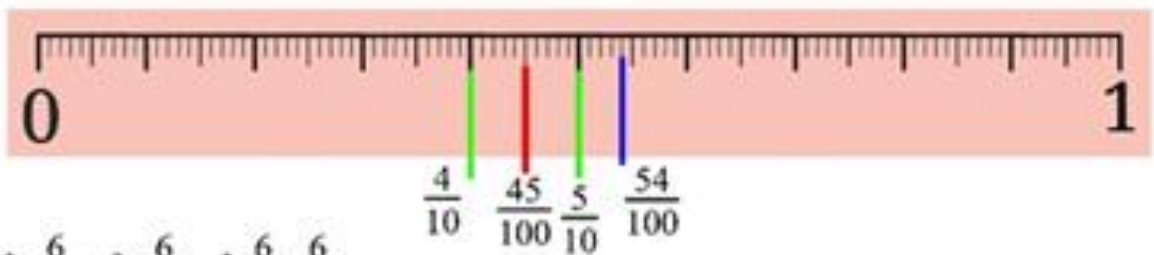

(d) $3\frac{6}{10}, 3\frac{6}{100}, 3\frac{6}{10}\frac{6}{100}$

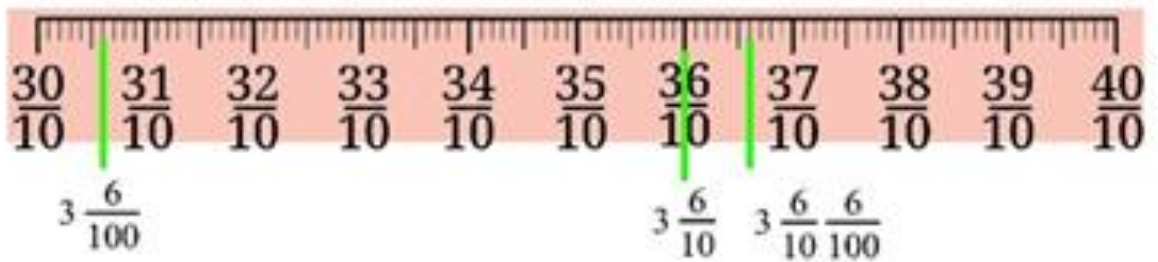

(a) Longest = $\frac{33}{100}$ Shortest = $\frac{3}{100}$

(b) Longest = $3\frac{1}{10}$ Shortest = $1\frac{3}{10}$

(c) Longest = $\frac{54}{100}$ Shortest = $\frac{4}{10}$

(d) Longest = $3\frac{6}{10}\frac{6}{100}$ Shortest = $3\frac{6}{100}$

(e) $\frac{8}{10} \frac{2}{100}, \frac{9}{100}, 1 \frac{8}{100}$



(f) $7 \frac{3}{10} \frac{5}{100}, 7 \frac{5}{10}, 7 \frac{41}{100}$

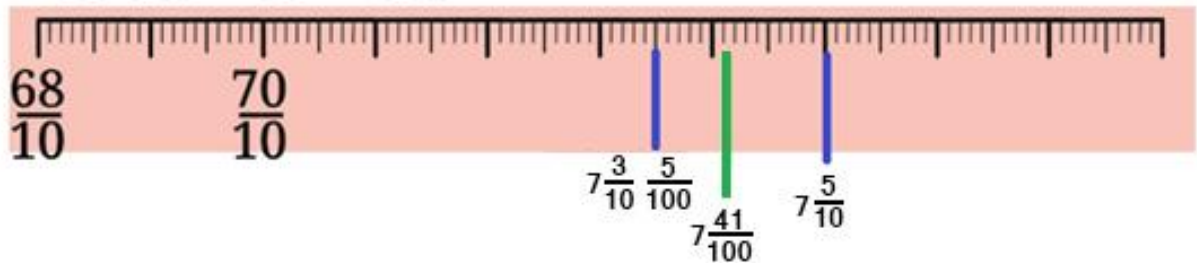

(g) $\frac{65}{10} \frac{15}{100}, 5 \frac{87}{100}, 5 \frac{7}{100}$

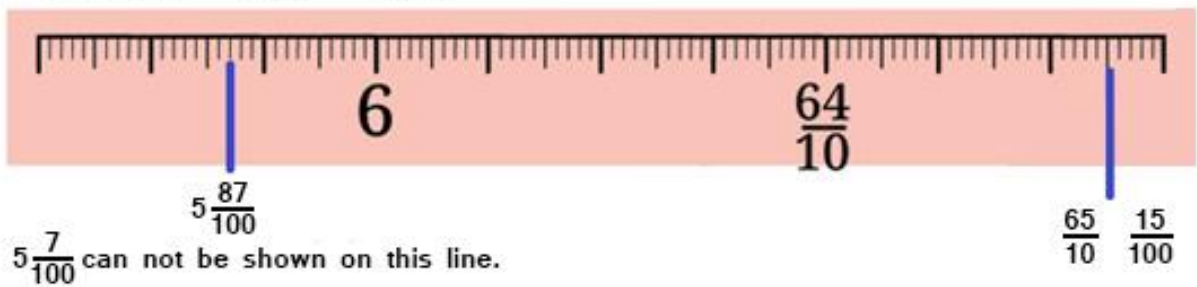

(e) Longest = $1 \frac{8}{100}$

Shortest = $\frac{9}{100}$

(f) Longest = $7 \frac{5}{100}$

Shortest = $7 \frac{3}{10} \frac{5}{100}$

(g) Longest = $\frac{65}{10} \frac{15}{100}$

Shortest = $5 \frac{7}{100}$

Page No. 58

② **Figure it Out**

Find the sums and differences

(a) $\frac{3}{10} + 3\frac{4}{100}$

Ans: $3\frac{34}{100}$

(b) $9\frac{5}{10}\frac{7}{100} + 2\frac{1}{10}\frac{3}{100}$

Ans: $11\frac{7}{10}$

(c) $15\frac{6}{10}\frac{4}{100} + 14\frac{3}{10}\frac{6}{100}$

Ans: 30

(d) $7\frac{7}{100} - 4\frac{4}{100}$

Ans: $3\frac{3}{100}$

(e) $8\frac{6}{100} - 5\frac{3}{100}$

Ans: $3\frac{3}{100}$

(f) $12\frac{6}{10}\frac{2}{100} - \frac{9}{10}\frac{9}{100}$

Ans: $11\frac{63}{100}$

Page No. 63

② **Make a place value table similar to the one above. Write each quantity in decimal form and in terms of place value, and read the number:**

Ans:

Question		Hundreds	Tens	Ones	Tenths	Hundredths	Thousandth	Decimal Form	Read as
a	2 ones, 3 tenths and 5 hundredths	-	-	2	3	5	-	$2 + \frac{3}{10} + \frac{5}{100}$ $= 2.35$	Two point three five (or two and thirty-five hundredths)
b	1 ten and 5 tenths	-	1	-	5	-	-	$10 + \frac{5}{10} = 10.5$	Ten point five (or ten and five tenths)
c	4 ones and 6 hundredths	-	-	4	-	6	-	$4 + 0 + \frac{6}{100}$ $= 4.06$	Four point zero six (or four and six hundredths)
d	1 hundred, 1 one and 1 hundredth	1	-	1	-	1	-	$100 + 0 + 1 + 0 + \frac{1}{100}$ $= 101.01$	One hundred one point zero one (or one hundred one and one hundredth)
e	$\frac{8}{100}$ and $\frac{9}{10}$	-	-	-	9	8	-	$\frac{9}{10} + \frac{8}{100}$ $= 0.98$	Zero point nine eight (or ninety-eight hundredths)

f	$\frac{5}{100}$	-	-	-		5	-	$\frac{5}{100} = 0.05$	Zero point zero five (or five hundredths)
g	$\frac{1}{10}$	-	-	-	1	-	-	$\frac{1}{10} = 0.1$	Zero point one (or one tenth)
h	$2\frac{1}{10}, 4\frac{1}{10},$ and $7\frac{7}{1000}$		-	2	0	1	-	2.01	Two point zero one and
				4	1	-	-	$4 + \frac{1}{10} = 4.1$	Four point one and
				7	-	-	7	$7 + \frac{0}{10} + \frac{0}{100} + \frac{7}{1000} = 7.007$	Seven point zero zero seven
								13.117	Thirteen point one one seven.

Page No. 64

❓ Write these quantities in decimal form:

(a) 234 hundredths

Ans: 2.34

(b) 105 tenths.

Ans: 10.5

② Fill in the blanks below (mm < - > cm)

Ans:

12 mm = 1.2 cm	56 mm = 5.6 cm	70 mm = <u>7.0 cm</u>
<u>9 mm</u> = 0.9 cm	134 mm = <u>13.4 cm</u>	<u>2036 mm</u> = 203.6 cm

Page No. 66

② Fill in blanks (cm <-> m):

36 cm = <u>0.36 m</u>	50 cm = <u>0.5 m</u>	<u>89 cm</u> = 0.89 m
4 cm = <u>0.04 m</u>	325 cm = <u>3.25 m</u>	<u>207 cm</u> = 2.07 m

② How many mm does 1 meter have?

Ans: 1m = 1000 mm

② Can we write $1 \text{ mm} = \frac{1}{1000} \text{ m}$?

Ans: Yes

Page No. 68

② Fill in the blanks below (g < - > kg)

Ans:

465 g = <u>0.465 kg</u>	68 g = <u>0.068 kg</u>	1560 g = <u>1.56 kg</u>
704 g = <u>0.704 kg</u>	<u>560 g</u> = 0.56 kg	<u>2500 g</u> = 2.5 kg

Page No. 69

② Fill in the blanks below (rupee < - > paise)

10 p = ₹0.10	5 p = ₹0.05	36 p = ₹0.36
50 p = ₹0.50	99 p = ₹0.99	250 p = ₹2.50

Page No. 70

② Name all the divisions between 1 and 1.1 on the number line.

Ans: The small divisions between 1 and 1.1 on the number line (if the sub-division is of 10 parts) are: 1.01, 1.02, 1.03, 1.04, 1.05, 1.06, 1.07, 1.08, 1.09

② Identify and write the decimal numbers against the letters.

Ans:

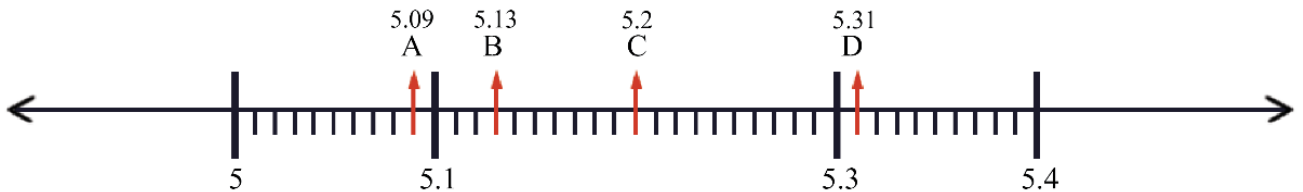

Page No. 71

② Can you tell which of these is the smallest and which is the largest?

Ans:

Decimal Number	Units	Tenths	Hundredths	Thousandths
0.2	0	2	0	0
0.20	0	2	0	0
0.200	0	2	0	0
0.02	0	0	2	0
0.002	0	0	0	2

0.2 = 0.20 = 0.200 is the largest.

0.002 is the smallest.

② Which of these are the same: 4.5, 4.05, 0.405, 4.050, 4.50, 4.005, 04.50?

Ans: 4.5, 4.50, and 04.50 are equal.

4.05 and 4.050 are equal.

② Identify the decimal number in the last number line in Figure (b) denoted by ‘?’

Ans:

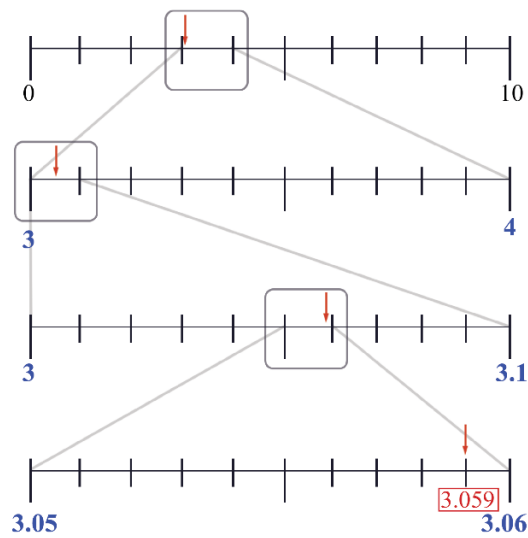

(b)

② Make such number lines for the decimal numbers: (a) 9.876 (b) 0.407.

Ans:

(a)

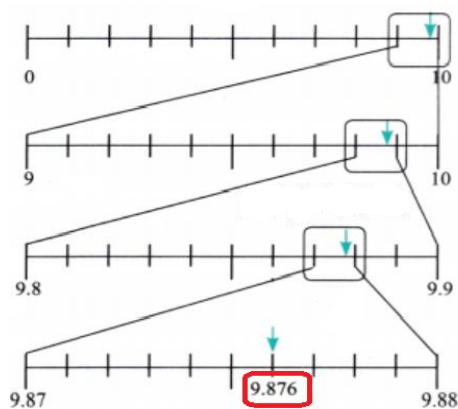

(b)

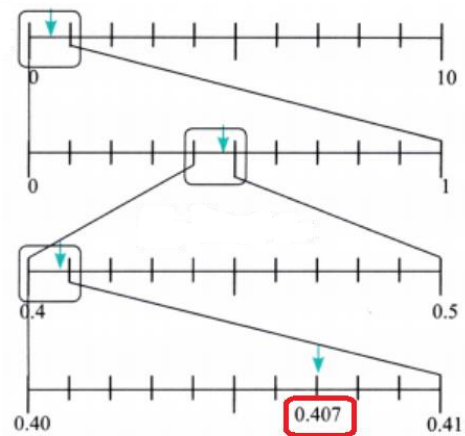

② In the number line shown below, what decimal numbers do the boxes labelled 'a', 'b', and 'c' denote?

Ans:

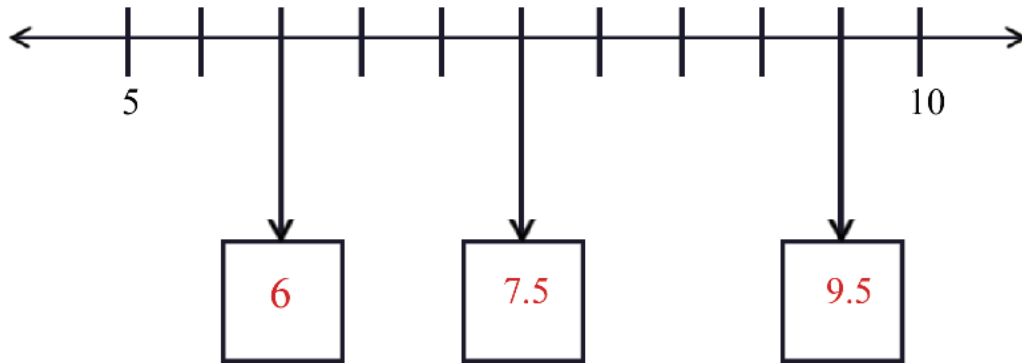

Page No. 72

② Using similar reasoning find out the decimal numbers in the boxes below.

Ans:

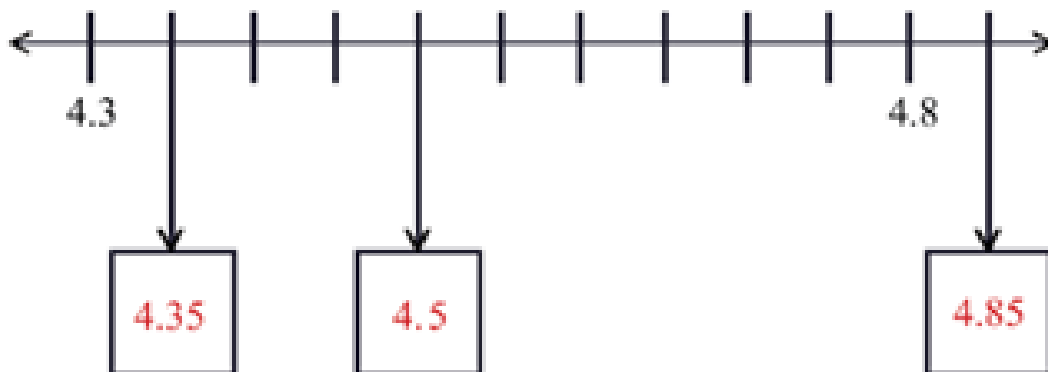
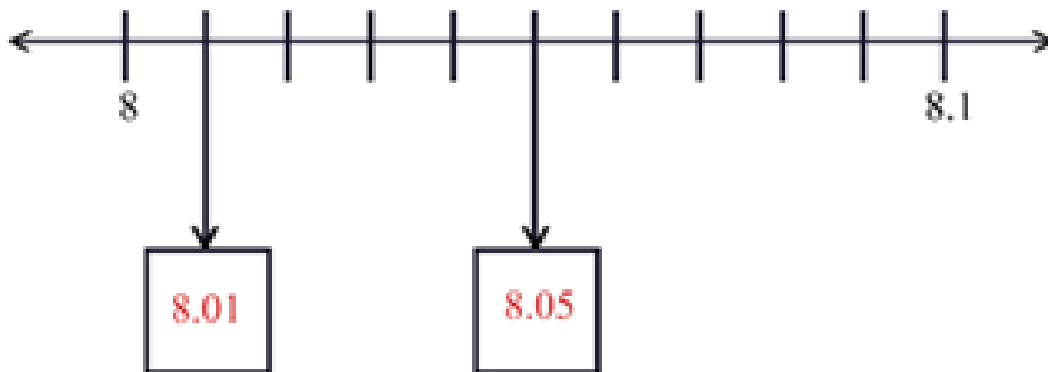

② Which decimal number is greater?

(a) 1.23 or 1.32 (b) 3.81 or 13.800 (c) 1.009 or 1.090

Ans:

(a) 1.32 is larger.

(b) 13.800 is larger.

(c) 1.090 is larger.

② Consider the decimal numbers 0.9, 1.1, 1.01 and 1.11
Which of the above is closest to 1.09?

Ans: 1.1 is closest to 1.09.

② Which among these is closest to 4: 3.56, 3.65, 3.099?

Ans: 3.65 is closest to 4.

② Which among these is closest to 1: 0.8, 0.69, 1.08?

Ans: 1.08 is closest to 1.

② In each case below use the digits 4, 1, 8, 2, and 5 exactly once and try to make a decimal number as close as possible to 25.

Ans:

2	5	.	1	4	8				
8						.	5	4	2
1	2	4	.	5	8				

② Figure it Out

1. Find the sums

(a) $5.3 + 2.6$

(b) $18 + 8.8$

(c) $2.15 + 5.26$

(d) $9.01 + 9.10$

(e) $29.19 + 9.91$

(f) $0.934 + 0.6$

(g) $0.75 + 0.03$

(h) $6.236 + 0.487$

Ans:

- | | |
|-----------|-----------|
| (a) 7.9 | (b) 26.8 |
| (c) 7.41 | (d) 18.11 |
| (e) 39.10 | (f) 1.534 |
| (g) 0.78 | (h) 6.723 |

2. Find the differences

- | | |
|------------------|---------------------|
| (a) $5.6 - 2.3$ | (b) $18 - 8.8$ |
| (c) $10.4 - 4.5$ | (d) $17 - 16.198$ |
| (e) $17 - 0.05$ | (f) $34.505 - 18.1$ |
| (g) $9.9 - 9.09$ | (h) $6.236 - 0.487$ |

Ans:

- | | |
|-----------|------------|
| (a) 3.3 | (b) 9.2 |
| (c) 5.9 | (d) 0.802 |
| (e) 16.95 | (f) 16.405 |
| (g) 0.81 | (h) 5.749 |

⊛ **Continue this sequence 4.4, 4.8, 5.2, 5.6, 6.0, ... and write the next 3 terms.**

Ans: 4.4, 4.8, 5.2, 5.6, 6.0, 6.4, 6.8, 7.2

Page No. 76

⊛ **Similarly, identify the change and write the next 3 terms for each sequence given below.**

Try to do this computation mentally.

- | | |
|------------------------------|------------------------------|
| (a) 4.4, 4.45, 4.5, ... | (b) 25.75, 26.25, 26.75, ... |
| (c) 10.56, 10.67, 10.78, ... | (d) 13.5, 16, 18.5, ... |
| (e) 8.5, 9.4, 10.3, ... | (f) 5, 4.95, 4.90, ... |
| (g) 12.45, 11.95, 11.45, ... | (h) 36.5, 33, 29.5, ... |

Ans:

- (a) 4.4, 4.45, 4.5, 4.55, 4.6, 4.65 □ increment of + 0.05
- (b) 25.75, 26.25, 26.75, 27.25, 27.75, 28.25 □ add 0.5
- (c) 10.56, 10.67, 10.78, 10.89, 11.0, 11.11 □ Add 0.11
- (d) 13.5, 16, 18.5, 21.0, 23.5, 26.0 □ Add 2.5

(e) 8.5, 9.4, 10.3, 11.2, 12.1, 13.0 □ Add 0.9

(f) 5, 4.95, 4.90, 4.85, 4.80, 4.75 □ Subtract 0.05

(g) 12.45, 11.95, 11.45, 10.95, 10.45, 9.95 □ Subtract 0.50

(h) 36.5, 33, 29.5, 26.0, 22.5, 19.0 □ Subtract 3.5

Page No. 78

? Figure it out

1. Convert the following fractions into decimals:

(a) $\frac{5}{100}$

(b) $\frac{16}{1000}$

(c) $\frac{12}{10}$

(d) $\frac{254}{1000}$

Ans:

(a) $\frac{5}{100} = 0.05$

(b) $\frac{16}{1000} = 0.016$

(c) $\frac{12}{10} = 1.2$

(d) $\frac{254}{1000} = 0.254$

Page No. 79

2. Convert the following decimals into a sum of tenths, hundredths and thousandths:

(a) 0.34

(b) 1.02

(c) 0.8

(d) 0.362

Ans:

(a) $\frac{3}{10} + \frac{4}{100}$

(b) $\frac{100}{100} + \frac{2}{100} = 1 + \frac{2}{100}$

(c) $\frac{8}{10}$

(d) $\frac{3}{10} + \frac{6}{100} + \frac{2}{1000}$

3. What decimal number does each letter represent in the number line below?

Ans:

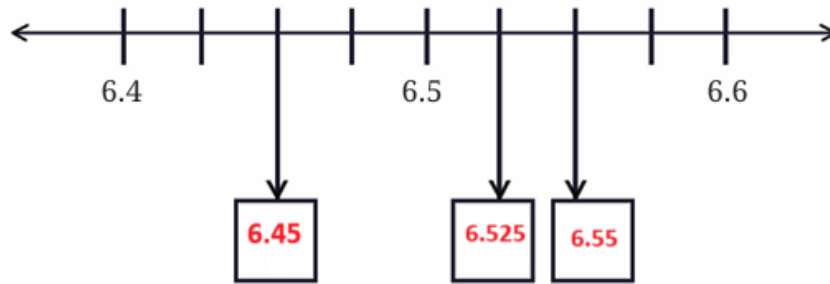

4. Arrange the following quantities in descending order:

(a) 11.01, 1.011, 1.101, 11.10, 1.01

□ Descending order: 11.10, 11.01, 1.101, 1.011, 1.01.

(b) 2.567, 2.675, 2.768, 2.499, 2.698

□ Descending order: 2.768, 2.698, 2.675, 2.567, 2.499.

(c) 4.678 g, 4.595 g, 4.600 g, 4.656 g, 4.666 g

□ Descending order: 4.678, 4.666, 4.656, 4.600, 4.595.

(d) 33.13 m, 33.31 m, 33.133 m, 33.331 m, 33.313 m

□ Descending order: 33.331, 33.313, 33.31, 33.133, 33.13.

5. Using the digits 1, 4, 0, 8, and 6 make: (a) the decimal number closest to 30 (b) the smallest possible decimal number between 100 and 1000.

Ans: Using the digits 1, 4, 0, 8, and 6, we can make:

(a) 40.168

(b) 104.68

6. Will a decimal number with more digits be greater than a decimal number with fewer digits?

Ans: No. It is not necessary. For example, 2.05 (2 digits after decimal) vs 2.5 (1 digit after decimal). $2.5 > 2.05$

7. Mahi purchases 0.25 kg of beans, 0.3 kg of carrots, 0.5 kg of potatoes, 0.2 kg of capsicums, and 0.05 kg of ginger. Calculate the total weight of the items she bought.

Ans: 1.3 kg

8. Pinto supplies 3.79 L, 4.2 L, and 4.25 L of milk to a milk dairy in the first three days. In 6 days, he supplies 25 liters of milk. Find the total quantity of milk supplied to the dairy in the last three days.

Ans: 12.76 L

9. Tinku weighed 35.75 kg in January and 34.50 kg in February. Has he gained or lost weight? How much is the change?

Ans: He has lost weight. The change in the weight = 1.25 kg

10. Extend the pattern: 5.5, 6.4, 6.39, 7.29, 7.28, 8.18, 8.17, ____, ____

Ans: 9.07, 9.06

11. How many millimeters make 1 kilometer?

Ans: 1000000 mm

12. Indian Railways offers optional travel insurance for passengers who book e-tickets. It costs 45 paise per passenger. If 1 lakh people opt for insurance in a day, what is the total insurance fee paid?

Ans: The total insurance fee paid for 1 lakh passengers is ₹45,000.

13. Which is greater?

(a) $\frac{10}{1000}$ or $\frac{1}{10}$?

(b) One-hundredth or 90 thousandths?

(c) One-thousandth or 90 hundredths?

Ans:

(a) $\frac{1}{10} > \frac{1}{100}$

(b) 90 thousandths > One-hundredth

(c) 90 hundredths > One-thousandth

Page No. 80

14. Write the decimal forms of the quantities mentioned (an example is given):

(a) 87 ones, 5 tenths and 60 hundredths

(b) 12 tens and 12 tenths

(c) 10 tens, 10 ones, 10 tenths, and 10 hundredths

(d) 25 tens, 25 ones, 25 tenths, and 25 hundredths

Ans:

- (a) 88.10 121.2
 (b) 111.1 277.75

15. Using each digit 0 – 9 not more than once, fill the boxes below so that the sum is closest to 10.5:

Ans:

$$\begin{array}{r}
 \boxed{9} \cdot \boxed{4} \boxed{7} \boxed{6} \\
 + \boxed{1} \cdot \boxed{0} \boxed{2} \boxed{5} \\
 \hline
 10 \cdot 5 \quad 0 \quad 1
 \end{array}$$

16. Write the following fractions in decimal form:

- (a) $\frac{1}{2}$ (b) $\frac{3}{2}$ (c) $\frac{1}{4}$
 (d) $\frac{3}{4}$ (e) $\frac{1}{5}$ (f) $\frac{4}{5}$

Ans:

- (a) 0.5 (b) 1.5 (c) 0.25
 (d) 0.75 (e) 0.2 (f) 0.8