

5

PARALLEL AND INTERSECTING LINES



5.1 Across the Line

Take a piece of square paper and fold it in different ways. Now, on the creases formed by the folds, draw lines using a pencil and a scale. You will notice different lines on the paper. Take any pair of lines and observe their relationship with each other. Do they meet? If they do not meet within the paper, do you think they would meet if they were extended beyond the paper?

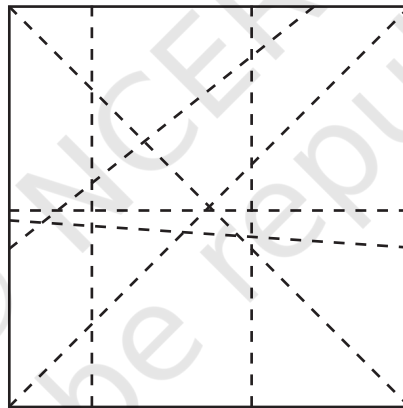

Fig. 5.1

In this chapter, we will explore the relationship between lines on a **plane surface**. The table top, your piece of paper, the blackboard, and the bulletin board are all examples of plane surfaces.

Let us observe a pair of lines that meet each other. You will notice that they meet at a point. When a pair of lines meet each other at a point on a plane surface, we say that the lines **intersect** each other. Let us observe what happens when two lines intersect.

 How many angles do they form?

In Fig. 5.2, where line l intersects line m , we can see that four angles are formed.

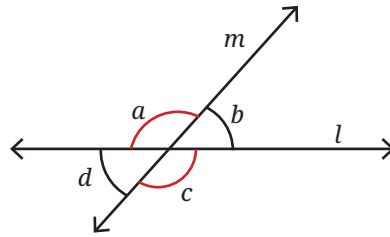

Fig. 5.2

- ? Can two straight lines intersect at more than one point?

Activity 1

Draw two lines on a plain sheet of paper so that they intersect. Measure the four angles formed with a protractor. Draw four such pairs of intersecting lines and measure the angles formed at the points of intersection.

- ? What patterns do you observe among these angles?
- ? In Fig. 5.2, if $\angle a$ is 120° , can you figure out the measurements of $\angle b$, $\angle c$ and $\angle d$, without drawing and measuring them?

We know that $\angle a$ and $\angle b$ together measure 180° , because when they are combined, they form a straight angle which measures 180° . So, if $\angle a$ is 120° , then $\angle b$ must be 60° .

Similarly, $\angle b$ and $\angle c$ together measure 180° . So, if $\angle b$ is 60° , then $\angle c$ must be 120° . And $\angle c$ and $\angle d$ together measure 180° . So, if $\angle c$ is 120° , then $\angle d$ must be 60° .

Therefore, in Fig. 5.2, $\angle a$ and $\angle c$ measure 120° , and $\angle b$ and $\angle d$ measure 60° .

When two lines intersect each other and form four angles, labelled a , b , c and d , as in Fig. 5.2, then $\angle a$ and $\angle c$ are equal, and $\angle b$ and $\angle d$ are equal!

- ? Is this always true for any pair of intersecting lines?

Check this for different measures of $\angle a$. Using these measurements, can you reason whether this property holds true for any measure of $\angle a$?

We can generalise our reasoning for Fig. 5.2, without assuming the values of $\angle a$.

Since straight angles measure 180° , we must have $\angle a + \angle b = \angle a + \angle d = 180^\circ$. Hence, $\angle b$ and $\angle d$ are always equal. Similarly, $\angle b + \angle a = \angle b + \angle c = 180^\circ$, so $\angle a$ and $\angle c$ must be equal.

Adjacent angles, like $\angle a$ and $\angle b$, formed by two lines intersecting each other, are called **linear pairs**. Linear pairs always add up to 180° .

Opposite angles, like $\angle b$ and $\angle d$, formed by two lines intersecting each other, are called **vertically opposite angles**. Vertically opposite angles are always equal to each other.

From the above reasoning, we conclude that whenever two lines intersect, vertically opposite angles are equal. Such a justification is called a **proof** in mathematics.

? Figure it Out

List all the linear pairs and vertically opposite angles you observe in Fig. 5.3:

Linear Pairs	$\angle a$ and $\angle b$, ...
Pairs of Vertically Opposite Angles	$\angle b$ and $\angle d$, ...

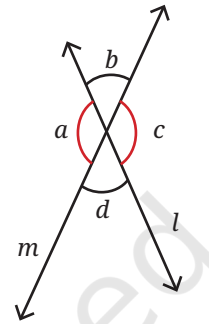

Fig. 5.3

Measurements and Geometry

You might have noticed that when you measure linear pairs, sometimes they may not add up to 180° . Or, when you measure vertically opposite angles they may be unequal sometimes. What are the reasons for this? There could be different reasons:

- Measurement errors because of improper use of measuring instruments — in this case, a protractor
- Variation in the thickness of the lines drawn. The “ideal” line in geometry does not have any thickness! But it is not possible for us to draw lines without any thickness

In geometry, we create ideal versions of “lines” and other shapes we see around us, and analyse the relationships between them. For example, we know that the angle formed by a straight line is 180° . So, if another line divides this angle into two parts, both parts should add up to 180° . We arrive at this simply through reasoning and not by measurement. When we measure, it might not be exactly so, for the reasons mentioned above. Still the measurements come out very close to what we predict, because of which geometry finds widespread application in different disciplines such as physics, art, engineering and architecture.

5.2 Perpendicular Lines

- ? Can you draw a pair of intersecting lines such that all four angles are equal? Can you figure out what will be the measure of each angle?

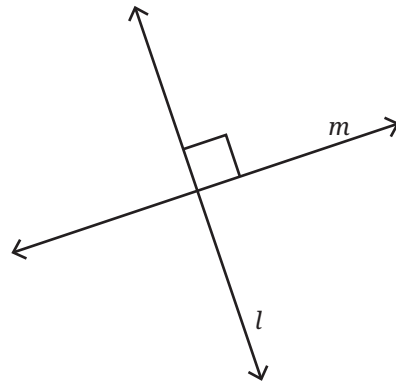

Fig. 5.4

If two lines intersect and all four angles are equal, then each angle must be a right angle (90°).

Perpendicular lines are a pair of lines which intersect each other at right angles (90°). In Fig. 5.4, we can say that lines l and m are perpendicular to each other.

5.3 Between Lines

Observe Fig. 5.5 and describe the way the line segments meet or cross each other in each case, with appropriate mathematical words (a point, an endpoint, the midpoint, meet, intersect) and the degree measure of each angle.

For example, line segments FG and FH meet at the endpoint F at an angle 115.3° .

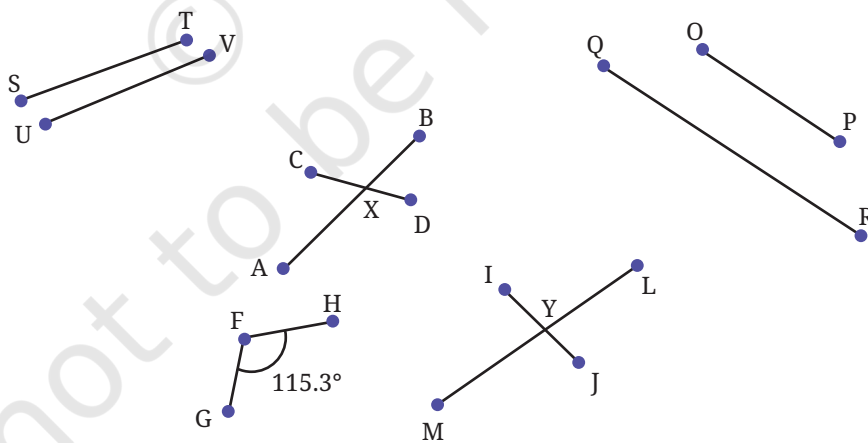

Fig. 5.5

Are line segments ST and UV likely to meet if they are extended?
 Are line segments OP and QR likely to meet if they are extended?
 Here are some examples of lines we notice around us.



What is common to the lines in the pictures above? They do not seem likely to intersect each other. Such lines are called parallel lines.

Parallel lines are a pair of lines that lie on the same plane, and do not meet however far we extend them at both ends.

Name some parallel lines you can spot in your classroom.

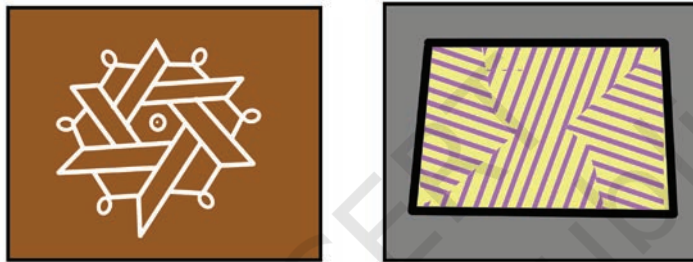

Parallel lines are often used in artwork and shading.

? Which pairs of lines appear to be parallel in Fig. 5.6 below?

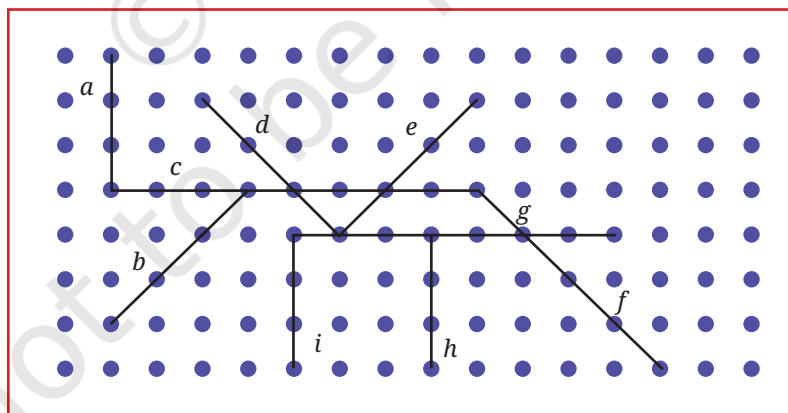

Fig. 5.6

Note to the Teacher: It is important that the lines lie on the same plane. A line drawn on a table and a line drawn on the board may never meet but that does not make them parallel.

5.4 Parallel and Perpendicular Lines in Paper Folding

? Activity 2

Take a plain square sheet of paper (use a newspaper for this activity).

- How would you describe the opposite edges of the sheet? They are _____ to each other.
- How would you describe the adjacent edges of the sheet? The adjacent edges are _____ to each other. They meet at a point. They form right angles.
- Fold the sheet horizontally in half. A new line is formed (see Fig. 5.7).
- How many parallel lines do you see now? How does the new line segment relate to the vertical sides?

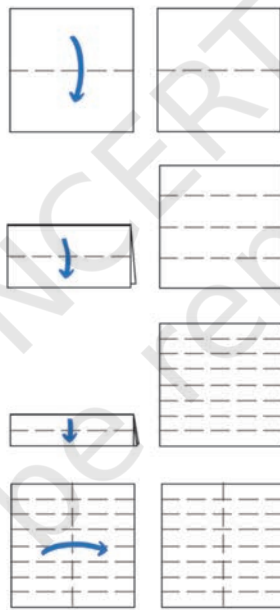

Fig. 5.7

- Make one more horizontal fold in the folded sheet. How many parallel lines do you see now?
- What will happen if you do it once more? How many parallel lines will you get? Is there a pattern? Check if the pattern extends further, if you make another horizontal fold.
- Make a vertical fold in the square sheet. This new vertical line is _____ to the previous horizontal lines.
- Fold the sheet along a diagonal. Can you find a fold that creates a line parallel to the diagonal line?

Here is another activity for you to try.

- Take a square sheet of paper, fold it in the middle and unfold it.
- Fold the edges towards the centre line and unfold them.
- Fold the top right and bottom left corners onto the creased line to create triangles. Refer to Fig. 5.8.
- The triangles should not cross the crease lines.
- Are a, b and c parallel to p, q and r respectively? Why or why not?



Fig. 5.8

Notations

In mathematics, we use an arrow mark ($>$) to show that a set of lines is parallel. If there is more than one set of parallel lines (as in Fig. 5.9), the second set is shown with two arrow marks and so on. Perpendicular lines are marked with a square angle between them.

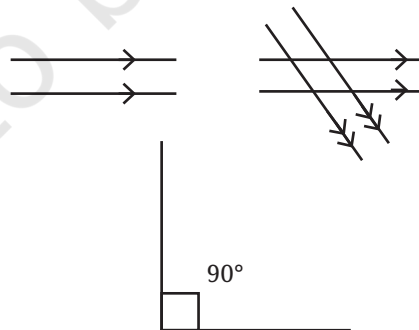

Fig. 5.9

Figure it Out

1. Draw some lines perpendicular to the lines given on the dot paper in Fig. 5.10.

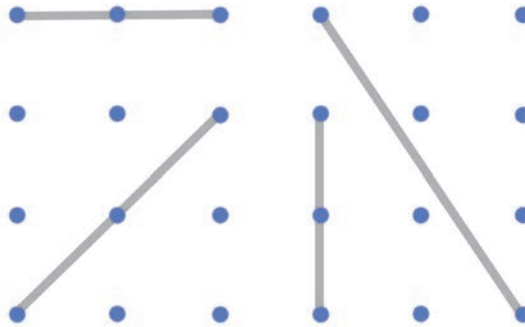

Fig. 5.10

2. In Fig. 5.11, mark the parallel lines using the notation given above (single arrow, double arrow etc.). Mark the angle between perpendicular lines with a square symbol.
 - (a) How did you spot the perpendicular lines?
 - (b) How did you spot the parallel lines?

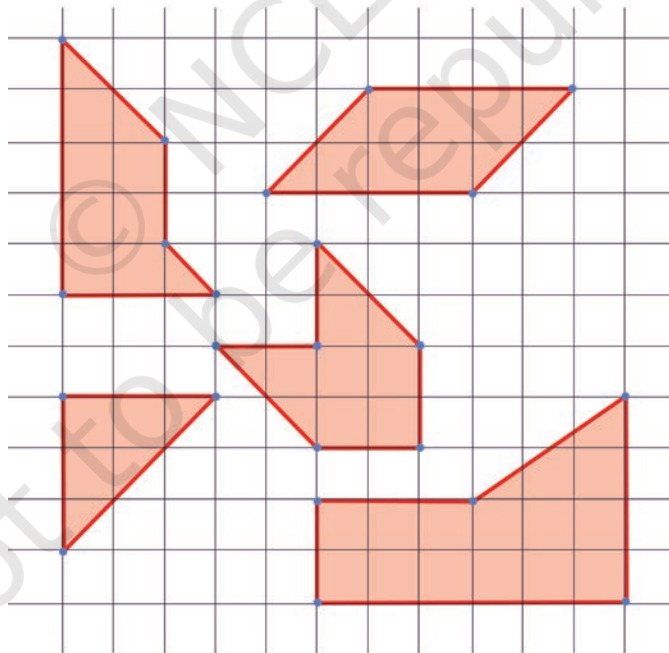

Fig. 5.11

3. In the dot paper following, draw different sets of parallel lines. The line segments can be of different lengths but should have dots as endpoints.

4. Using your sense of how parallel lines look, try to draw lines parallel to the line segments on this dot paper.

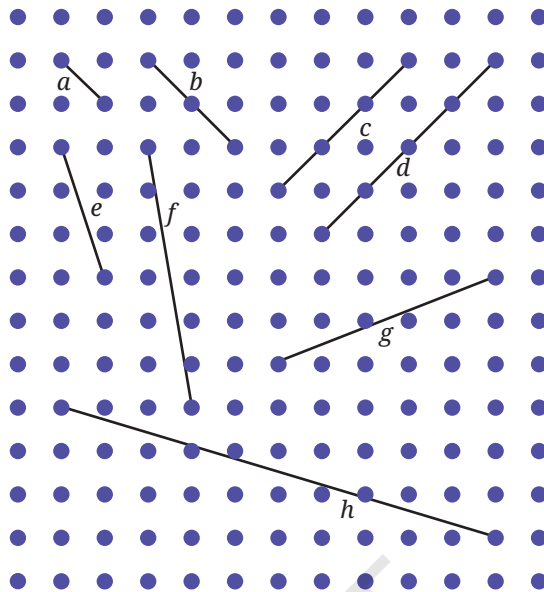

Fig. 5.12

- (a) Did you find it challenging to draw some of them?
 (b) Which ones?
 (c) How did you do it?
5. In Fig. 5.13, which line is parallel to line a — line b or line c ? How do you decide this?

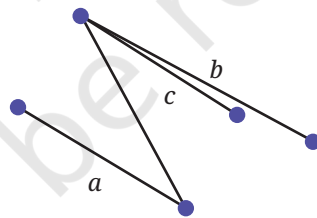

Fig. 5.13

Note to the Teacher: It is easier to draw vertical and horizontal lines and the ones inclined at 45° (on rectangular dot sheets), but drawing a line parallel to one which has a different orientation is slightly harder. Let students use their intuition for this.

From previous exercises we observed that sometimes it is difficult to be sure whether two lines are parallel. To determine this we use the idea of transversals.

5.5 Transversals

We saw what happens when two lines intersect in different ways. Let us explore what happens when one line intersects two different lines.

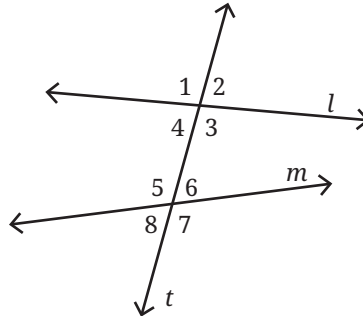

Fig. 5.14

In Fig. 5.14, line t intersects lines l and m . t is called a **transversal**. Notice that 8 angles are formed when a line crosses a pair of lines.

- ① Is it possible for all the eight angles to have different measurements? Why, why not?
- ① What about five different angles — 6, 5, 4, 3 and 2?

In Fig. 5.14, since $\angle 1$ and $\angle 3$ are vertically opposite angles, they are equal. Are there other pairs of vertically opposite angles? We can see that there are a total of four pairs of vertically opposite angles and in each pair, the angles are equal to each other.

Thus, when a transversal intersects two lines, it forms eight angles with a maximum of four distinct angle measures.

5.6 Corresponding Angles

In Fig. 5.14, we notice that the transversal t forms two sets of angles — one with line l and another with line m . There are angles in the first set that correspond to angles in the second set based on their position. $\angle 1$ and $\angle 5$ are called **corresponding angles**. Similarly, $\angle 2$ and $\angle 6$, $\angle 3$ and $\angle 7$, $\angle 4$ and $\angle 8$ are the corresponding angles formed when transversal t intersects lines l and m .

- ① **Activity 3**
Draw a pair of lines and a transversal such that they form two distinct angles.

Step 1: Draw a line l and a transversal t intersecting it at point X .

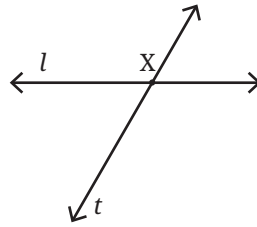

Fig. 5.15

Step 2: Measure $\angle a$ formed by lines l and t (let us say it is 60°).

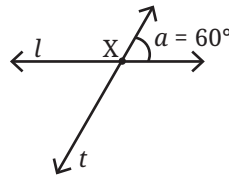

Fig. 5.16

How many distinct angles have formed now?

If one angle is 60° , the other angle of the linear pair should be 120° .

So, we already have two distinct angles.

So, when we draw another line intersecting the transversal t we wish to form only two angles, 60° and 120° .

Step 3: Mark a point Y on line t .

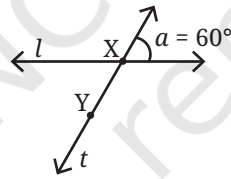

Fig. 5.17

Step 4: Draw a line m through point Y that forms a 60° angle to line t . This can be done either by copying $\angle a$ with a tracing paper or you can use a protractor to measure the angles.

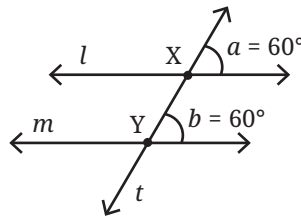

Fig. 5.18

What do you observe about lines l and m ? Do they appear to be parallel to each other?

Yes, they do appear to be parallel to each other.

Angles, $\angle a$ and $\angle b$ are corresponding angles formed by the transversal t on lines l and m . These corresponding angles are equal to each other.

From this we can observe:

When the corresponding angles formed by a transversal on a pair of lines are equal to each other, then the pair of lines are parallel to each other.

Suppose, we have a transversal intersecting two parallel lines. What can be said about the corresponding angles?

Activity 4

Fig. 5.19 has a pair of parallel lines l and m (what is the notation used in the figure to indicate they are parallel?) . Line t is the transversal across these two lines. $\angle a$ and $\angle b$ are corresponding angles. Take a tracing paper and trace $\angle a$ on it. Now place this tracing paper over $\angle b$ and see if the angles align exactly. You will observe that the angles match. Check the other corresponding angles in the figure using a protractor. Are all the corresponding angles equal to each other?

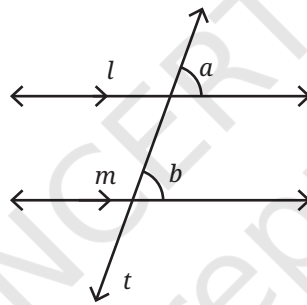

Fig. 5.19

Corresponding angles formed by a transversal intersecting a pair of parallel lines are always equal to each other.

Activity 5

In Fig. 5.20, draw a transversal t to the lines l and m such that one pair of corresponding angles is equal. You can measure the angles with a protractor.

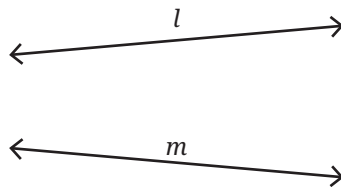

Fig. 5.20

Are you finding it hard to draw a transversal such that the corresponding angles are equal?

When a pair of lines are not parallel to each other, the corresponding angles formed by a transversal can never be equal to each other.

5.7 Drawing Parallel Lines

Can you draw a pair of parallel lines using a ruler and a set square?

Fig. 5.21 shows how you can do it.

Draw a line l with a scale. By sliding your set square you can make two lines perpendicular to line l .

Are these two lines parallel to each other? How are we sure that they are parallel to each other? What angles are formed between these lines and line l ?

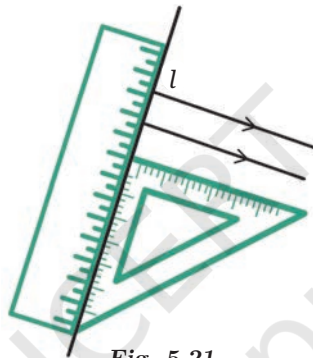

Fig. 5.21

Since we used a set square, the angles measure 90° . The position of the lines is different, but they make the same angle with l . If line l is seen as a transversal to the two new lines, then the corresponding angles measure 90° .

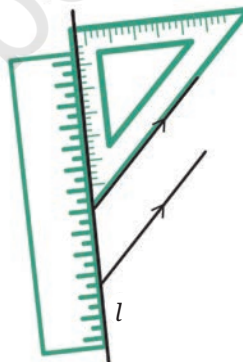

Fig. 5.22

As we know these are corresponding angles and they are equal, we can be sure that the lines are parallel.

Draw two more parallel lines using the long side of the set square as shown in Fig. 5.22.

How do you know these two lines are parallel? Can you check if the corresponding angles are equal?

Note to the Teacher: Students should be encouraged to check the equality of corresponding angles both by using the tracing method and using protractors to measure the angles. Pay attention to the language used to make the relationship between corresponding angles and parallel lines. Equality of corresponding angles is both necessary and sufficient for the pair of lines to be parallel to each other.

? Figure it Out

Can you draw a line parallel to l , that goes through point A ? How will you do it with the tools from your geometry box? Describe your method.

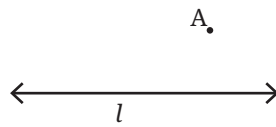

Fig. 5.23

Making Parallel Lines through Paper Folding

Let us try to do the same with paper folding. For a line l (given as a crease), how do we make a line parallel to l such that it passes through point A ?

We know how to fold a piece of paper to get a line perpendicular to l . Now, try to fold a perpendicular to l such that it passes through point A . Let us call this new crease t .

Now, fold a line perpendicular to t passing through A again. Let us call this line m . The lines l and m are parallel to each other.

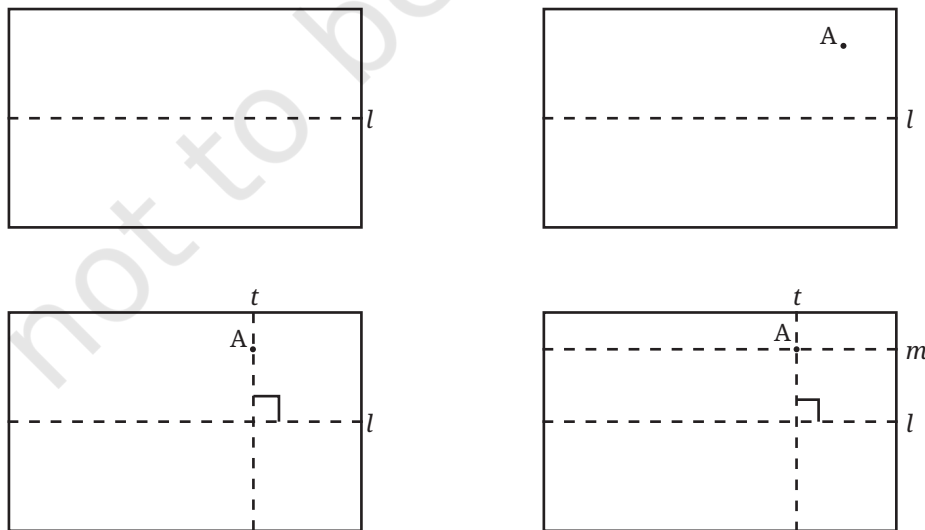

Fig. 5.24

? Why are lines l and m parallel to each other?

5.8 Alternate Angles

In Fig. 5.25, $\angle d$ is called the **alternate angle** of $\angle f$, and $\angle c$ is the alternate angle of $\angle e$.

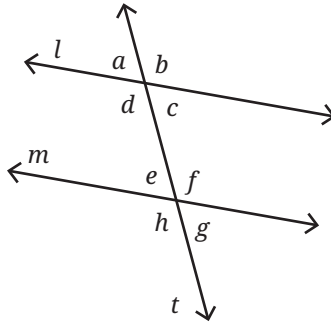

Fig. 5.25

You can find the alternate angle of a given angle, say $\angle f$, by first finding the corresponding angle of $\angle f$, which is $\angle b$ and then finding the vertically opposite angle of $\angle b$, which is $\angle d$.

? Activity 6

In Fig. 5.25, if $\angle f$ is 120° what is the measure of its alternate angle $\angle d$?

We can find the measure of $\angle d$ if we know $\angle b$ because they are vertically opposite angles. Remember, vertically opposite angles are equal.

What is the measure of $\angle b$? It is 120° because it is the corresponding angle of $\angle f$.

So, $\angle d$ also measures 120° .

In fact, $\angle f = \angle b$ irrespective of the measure of $\angle f$. Why? Because $\angle b$ is the corresponding angle of $\angle f$.

Similarly, $\angle b = \angle d$ irrespective of the measure of $\angle b$. Why? Because $\angle d$ is the vertically opposite angle of $\angle b$. So, it must always be the case that

$$\angle f = \angle d$$

Using our understanding of corresponding angles without any measurements, we have justified that alternate angles are always equal.

Alternate angles formed by a transversal intersecting a pair of parallel lines are always equal to each other.

? **Example 1:** In Fig. 5.26, parallel lines l and m are intersected by the transversal t . If $\angle 6$ is 135° , what are the measures of the other angles?



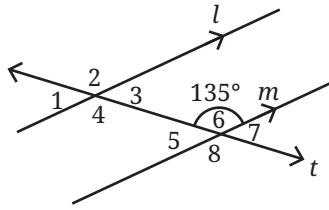

Fig. 5.26

Solution: $\angle 6$ is 135° , so $\angle 2$ is also 135° , because it is the corresponding angle of $\angle 6$ and the lines l and m are parallel.

$\angle 8$ is 135° , because it is the vertically opposite angle of $\angle 6$. $\angle 4$ is 135° because it is the corresponding angle of $\angle 8$.

$\angle 2$ is 135° because it is the vertically opposite angle of $\angle 4$. So, $\angle 2$, $\angle 4$, $\angle 6$, and $\angle 8$ are all 135° .

$\angle 5$ and $\angle 6$ are a linear pair, together they measure 180° . If $\angle 6$ is 135° , then

$$\angle 5 = 180 - 135 = 45^\circ$$

We can similarly find out that $\angle 1$, $\angle 3$, and $\angle 7$ measure 45° .

- ?** **Example 2:** In Fig. 5.27, lines l and m are intersected by the transversal t . If $\angle a$ is 120° and $\angle f$ is 70° , are lines l and m parallel to each other?

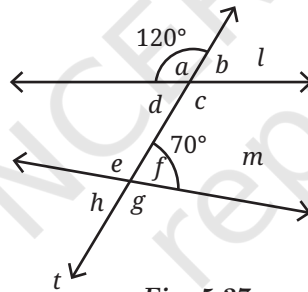

Fig. 5.27

Solution: $\angle a$ is 120° , so $\angle b$ is 60° because $\angle a$ and $\angle b$ form a linear pair. $\angle b$ is a corresponding angle of $\angle f$. If l and m are parallel, $\angle b$ should be equal to $\angle f$, however, they are not equal.

Therefore, lines l and m are not parallel to each other as the corresponding angles formed by the transversal t are not equal to each other.

- ?** **Example 3:** In Fig. 5.28, parallel lines l and m are intersected by the transversal t . If $\angle 3$ is 50° , what is the measure of $\angle 6$?

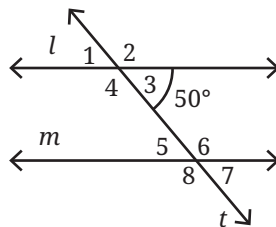

Fig. 5.28

Solution: $\angle 3$ is 50° ; therefore, $\angle 2$ is 130° , because $\angle 2$ and $\angle 3$ form a linear pair, and linear pairs always add up to 180° .

$\angle 2$ and $\angle 6$ are corresponding angles, and they need to be equal since lines l and m are parallel.

So, $\angle 6$ is 130° .

Angles $\angle 3$ and $\angle 6$ are called **interior angles**.

Is there a relation between $\angle 3$ and $\angle 6$? You could try to find the relationship by taking different values for $\angle 3$ and see what $\angle 6$ is. Once you find a relation, try to justify it or prove that this relation holds always. You will find that the sum of the interior angles on the same side of the transversal always add up to 180° .

Example 4: In Fig. 5.29, line segment AB is parallel to CD and AD is parallel to BC . $\angle DAC$ is 65° and $\angle ADC$ is 60° . What are the measures of angles $\angle CAB$, $\angle ABC$, and $\angle BCD$?

Solution: Let us observe the parallel lines AB and CD . AD is a transversal of these two lines.

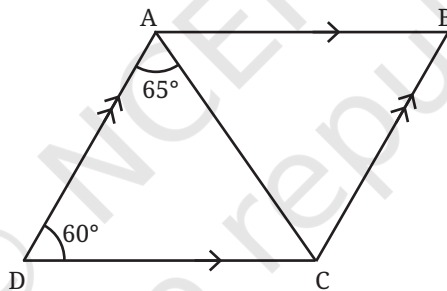

Fig. 5.29

We know that the sum of the interior angles formed by a transversal on a pair of parallel lines adds up to 180° . So

$$\angle ADC + \angle DAB = 180^\circ$$

$$60^\circ + \angle DAB = 180^\circ.$$

$$\text{So } \angle DAB = 120^\circ.$$

Can we find $\angle CAB$ from this?

$$\angle DAB = \angle DAC + \angle CAB.$$

$$\text{So } 120^\circ = 65^\circ + \angle CAB.$$

$$\text{So } \angle CAB = 55^\circ.$$

Let us observe the parallel line segments AD and BC . They are intersected by a transversal CD . So, $\angle ADC + \angle BCD = 180^\circ$, because they are interior angles on the same side of the transversal. Since $\angle ADC$ is given as 60° , $\angle BCD = 120^\circ$

Similarly, we find $\angle ABC = 60^\circ$.

Therefore, in Fig. 5.29, $\angle CAB = 55^\circ$, $\angle ABC = 60^\circ$, and $\angle BCD = 120^\circ$.

? Figure it Out

1. Find the angles marked below.

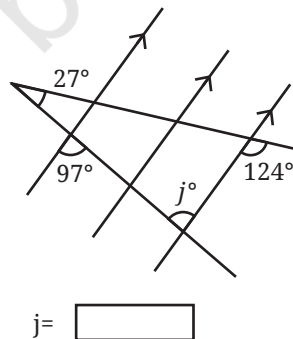
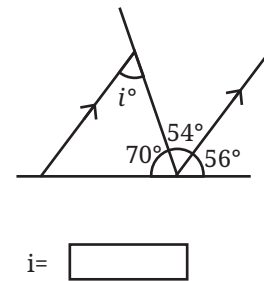
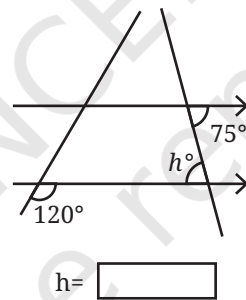
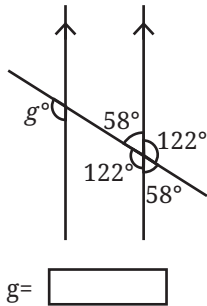
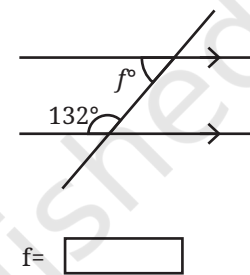
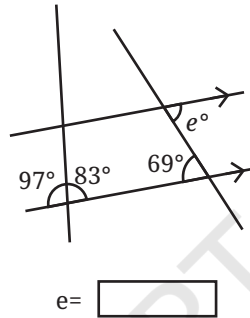
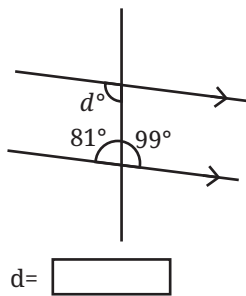
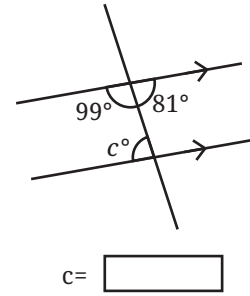
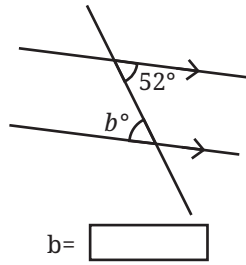
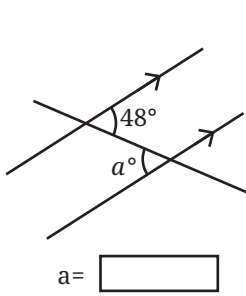

Fig. 5.30

2. Find the angle represented by a .

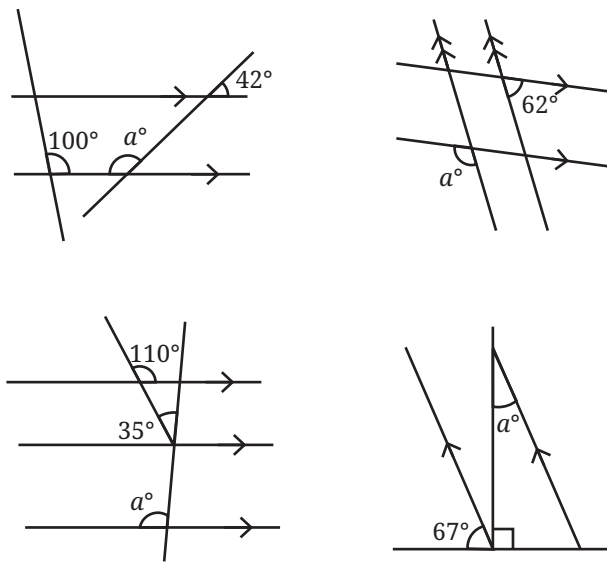

Fig. 5.31

3. In the figures below, what angles do x and y stand for?

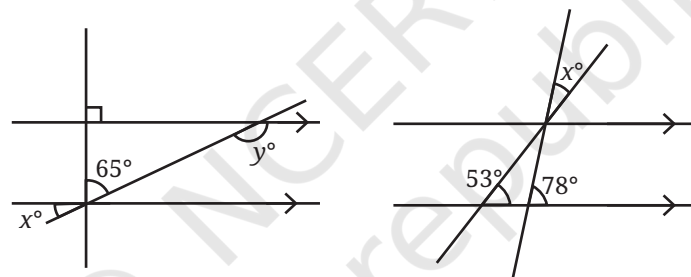

Fig. 5.32

4. In Fig. 5.33, $\angle ABC = 45^\circ$ and $\angle IKJ = 78^\circ$. Find angles $\angle GEH$, $\angle HEF$, $\angle FED$

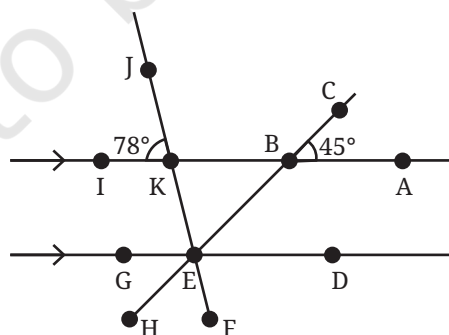

Fig. 5.33

5. In Fig. 5.34, AB is parallel to CD and CD is parallel to EF . Also, EA is perpendicular to AB . If $\angle BEF = 55^\circ$, find the values of x and y .

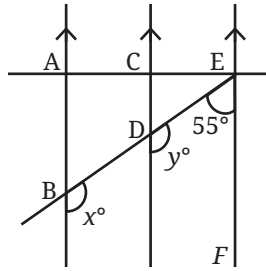

Fig. 5.34

6. What is the measure of angle $\angle NOP$ in Fig. 5.35?

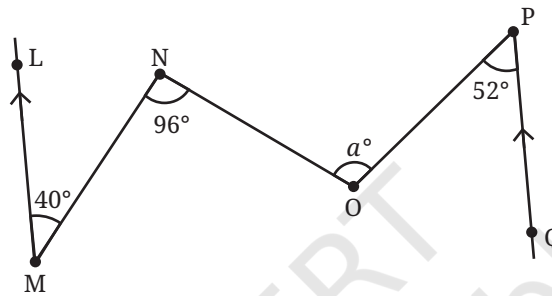
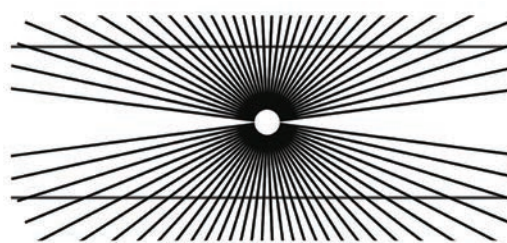
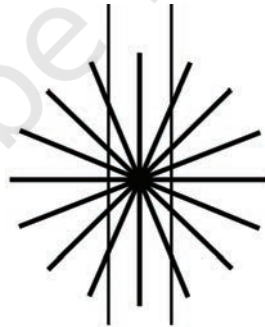

Fig. 5.35

[Hint: Draw lines parallel to LM and PQ through points N and O .]

5.9 Parallel Illusions

There do not seem to be any parallel lines here. Or, are there?



What causes these illusions?

SUMMARY

- When two lines intersect, they form four angles. The vertically opposite angles are equal and the linear pairs add up to 180° .
- When two lines intersect and the angles formed are 90° (i.e., all four angles are equal), the lines are said to be perpendicular to each other.
- When two lines never intersect on a plane, they are called parallel lines.
- When a line t intersects another pair of lines, it is called a transversal and it forms 2 sets of 4 angles. Each of the 4 angles in the first set has a corresponding angle in the second set.
- When a transversal intersects a pair of parallel lines, the corresponding angles are equal. When a transversal intersects a pair of lines and the corresponding angles are equal, then the pair of lines is parallel.
- When a transversal intersects a pair of parallel lines, the alternate angles are equal.
- The interior angles on the same side formed by a transversal intersecting a pair of parallel lines always add up to 180° .

Chapter – 5

Parallel and Intersecting Lines

Page No. 107

❓ Can two straight lines intersect at more than one point?

Ans: No

❓ What patterns do you observe among these angles?

Ans:

$$\angle a = \angle c \text{ and } \angle b = \angle d.$$

$$\angle a + \angle b = 180^\circ \text{ and } \angle b + \angle c = 180^\circ.$$

Find more such relations.

❓ Is this always true for any pair of intersecting lines?

Ans: Yes

Page No. 108.

❓ Figure it Out

List all the linear pairs and vertically opposite angles you observe in

Fig. 5.3:

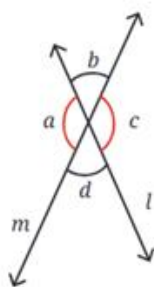

Linear Pairs	$\angle a$ and $\angle b, \dots$
Pairs of Vertically Opposite Angles	$\angle b$ and $\angle d, \dots$

Fig. 5.3

Ans:

Linear Pairs	$\angle a$ and $\angle b, \angle b$ and $\angle c, \angle c$ and $\angle d, \angle d$ and $\angle a.$
Pairs of Vertically Opposite Angles	$\angle b$ and $\angle d, \angle a$ and $\angle c$

② Which pairs of lines appear to be parallel in Fig. 5.6 below?

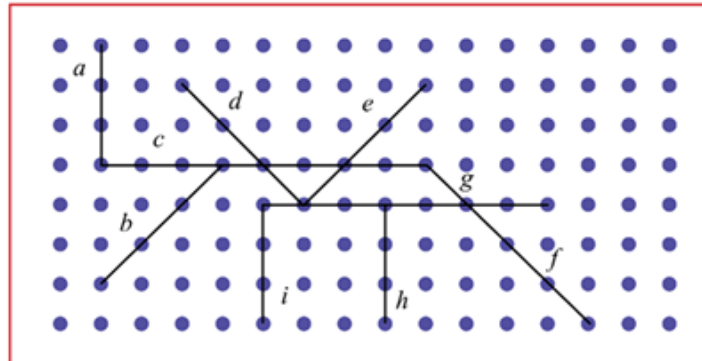

Fig. 5.6

Ans: *a, i and h; c and g; d and f; e and b*

Activity 2

Take a plain square sheet of paper (use a newspaper for this activity).

- How would you describe the opposite edges of the sheet? They are _____ to each other.
- How would you describe the adjacent edges of the sheet? The adjacent edges are _____ to each other. They meet at a point. They form right angles.
- Fold the sheet horizontally in half. A new line is formed (see Fig. 5.7).
- How many parallel lines do you see now? How does the new line segment relate to the vertical sides?



Fig. 5.7

- Make one more horizontal fold in the folded sheet. How many parallel lines do you see now?
- What will happen if you do it once more? How many parallel lines will you get? Is there a pattern? Check if the pattern extends further, if you make another horizontal fold.
- Make a vertical fold in the square sheet. This new vertical line is _____ to the previous horizontal lines.
- Fold the sheet along a diagonal. Can you find a fold that creates a line parallel to the diagonal line?

Ans:

Fill in the Blanks

- The opposite edges of the sheet are **parallel** to each other.
- The adjacent edges of the sheet are **perpendicular** to each other.

First Horizontal Fold

- We will see **three** parallel lines. The new line segment is **perpendicular** to the vertical sides.

Subsequent Horizontal Folds

- After one more horizontal fold, we will see a total of **five** parallel lines. The two original horizontal edges, the first fold line, and the second fold line are all parallel to each other.
- If we fold it horizontally one more time, we will get **nine** parallel lines. Yes, the pattern is $2^n + 1$, where n is the number of folds.

Vertical and Diagonal Folds

- This new vertical line is **perpendicular** to the previous horizontal lines.
- Yes, we can find a fold that creates a line parallel to the diagonal line.

Page No. 112

Here is another activity for you to try.

- Take a square sheet of paper, fold it in the middle and unfold it.
- Fold the edges towards the centre line and unfold them.
- Fold the top right and bottom left corners onto the creased line to create triangles. Refer to Fig. 5.8.
- The triangles should not cross the crease lines.
- Are a , b and c parallel to p , q and r respectively? Why or why not?



Fig. 5.8

Ans:

- Line segments a , b and c are parallel to Line segments p , q and r respectively.
- a and p lie on parallel lines. b , q are both respectively perpendicular to these, so are parallel to each other.
- c , r are both parallel because the triangular folds create lines parallel to the same diagonal.

🔍 Figure it Out

1. Draw some lines perpendicular to the lines given on the dot paper in the Figure.

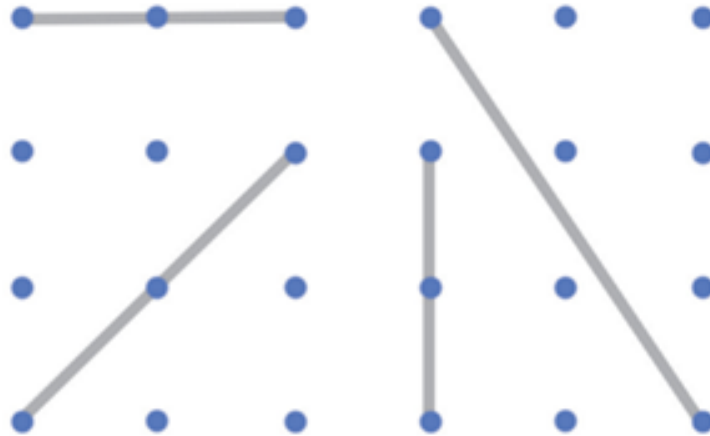
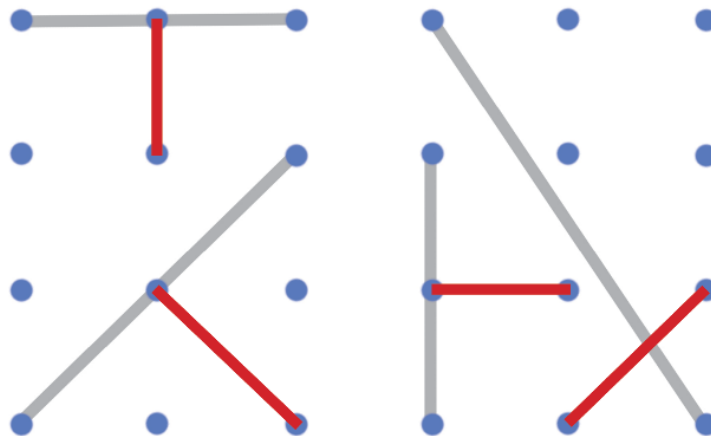

Fig. 5.10

Ans:



2. In the given Fig.5.11, mark the parallel lines using the notation given above (single arrow, double arrow, etc). Mark the angle between perpendicular lines with a square symbol.

(a) How did you spot the perpendicular lines?

(b) How did you spot the parallel lines?

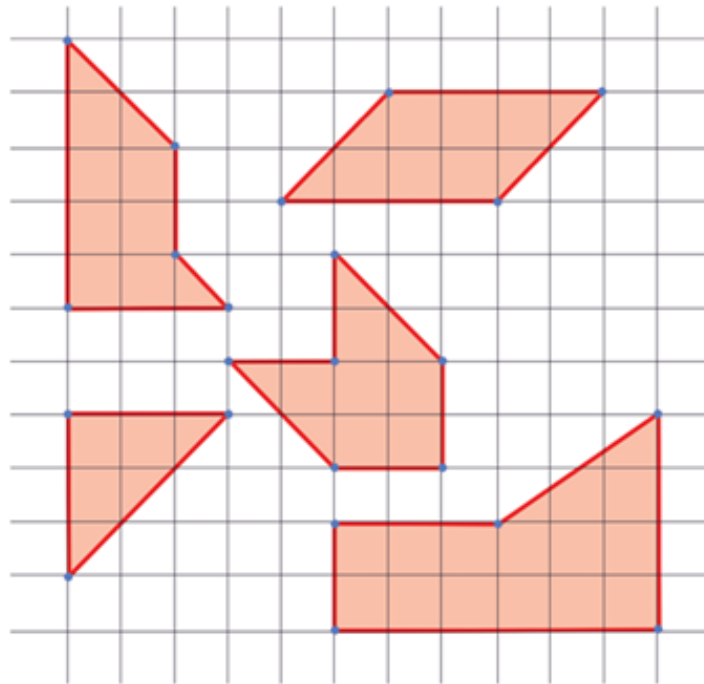
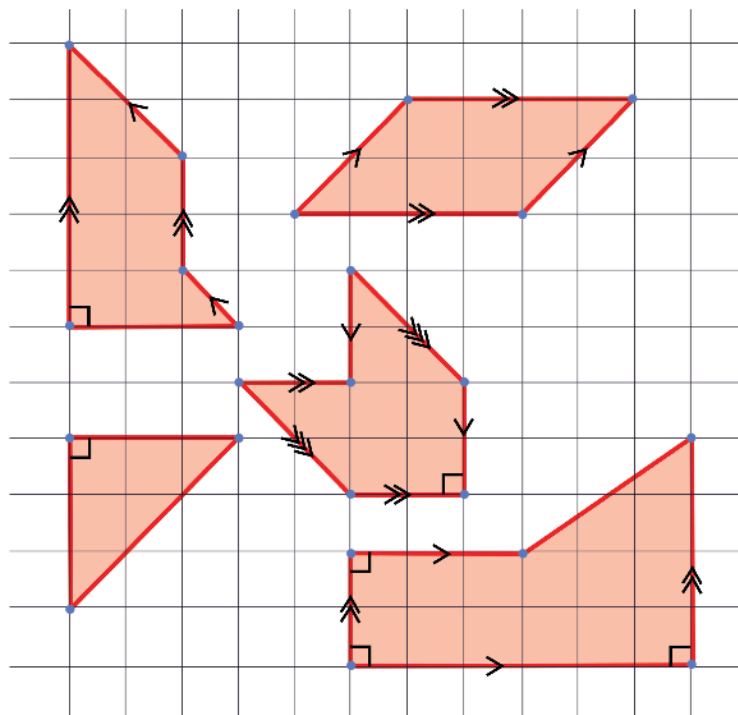

Fig. 5.11



Ans:

- (a) The vertical and horizontal lines on the grid paper meet at a 90-degree angle (a right angle)
- (b) By identifying lines that always remain the same distance apart.

3. In the dot paper following, draw different sets of parallel lines. The line segments can be of different lengths but should have dots as endpoints.

Ans: Some of the lines are:

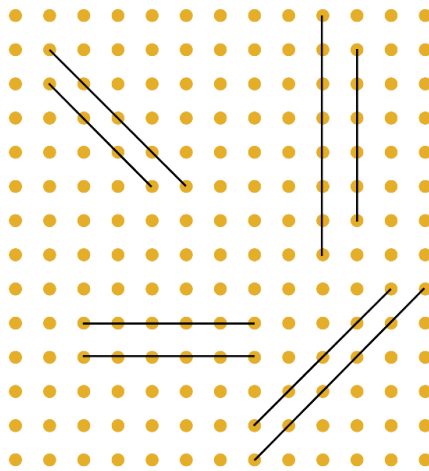

4. Using your sense of how parallel lines look, try to draw lines parallel to the line segments on this dot paper.

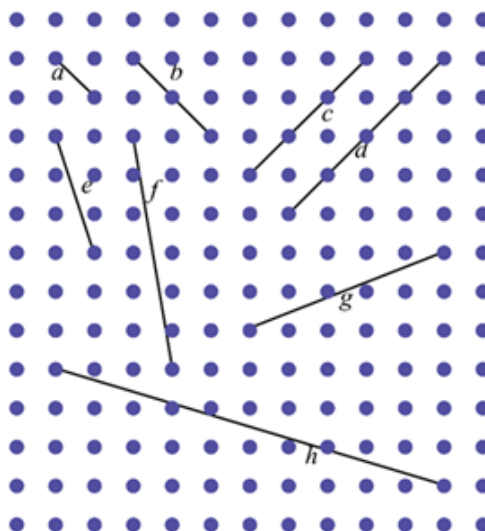

- (a) Did you find it challenging to draw some of them?
- (b) Which ones?
- (c) How did you do it?

Ans: Some of the lines are

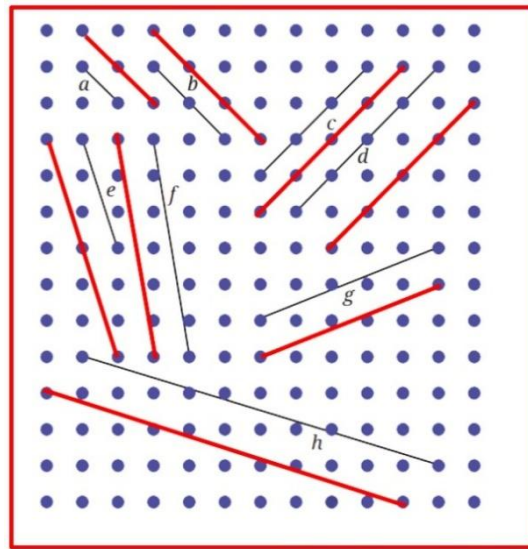

- (a) Yes
- (b) Line segments e, f, h, and g.
- (c) Parallel lines are drawn by keeping them equidistant from the given line.

5. In Fig 5.13, which line is parallel to line *a* — line *b* or line *c*? How do you decide this?

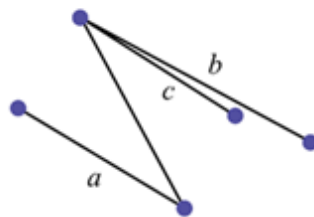
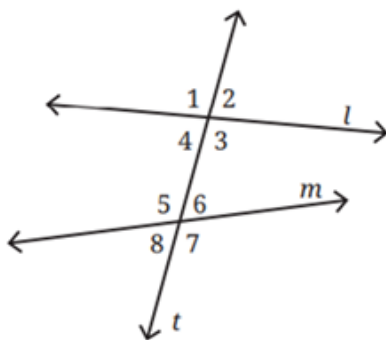

Fig. 5.13

Ans: In the given figure, line *c* is parallel to line *a* because these two lines are always at the same distance apart.



② Is it possible for all the eight angles to have different measurements? Why, why not?

Ans: No, because $\angle 1 = \angle 3$, $\angle 2 = \angle 4$, $\angle 5 = \angle 7$, and $\angle 6 = \angle 8$ (vertically opposite angles are equal).

What about five different angles — 6, 5, 4, 3 and 2?

Ans: No, because $\angle 2 = \angle 4$.

② Figure it Out

Can you draw a line parallel to l , that goes through point A? How will you do it with the tools from your geometry box? Describe your method.

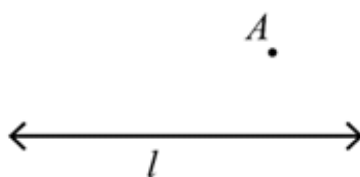

Ans:

Tools required: Ruler, Set-squares (right-angled triangle), Pencil, eraser

Steps:

1. Place the set square so that one side is along the line l .
2. Hold the ruler against the other side of the set square so that the ruler won't move.
3. Slide the set square along the ruler until one side reaches point A.
4. Draw a line along the edge of the set square through point A.

5. This new line is parallel to line l and passes through point A.

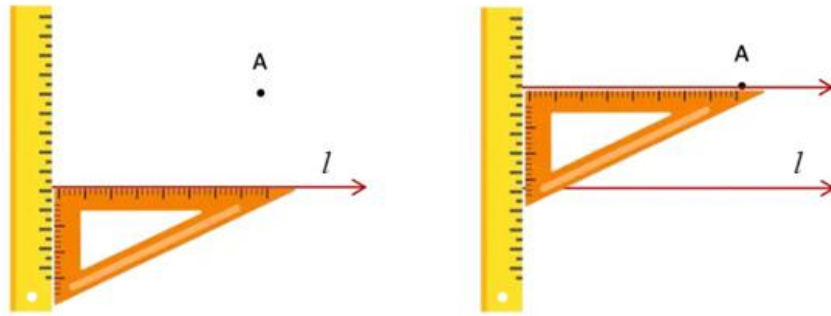

Page No. 120.

② Why are lines l and m parallel to each other?

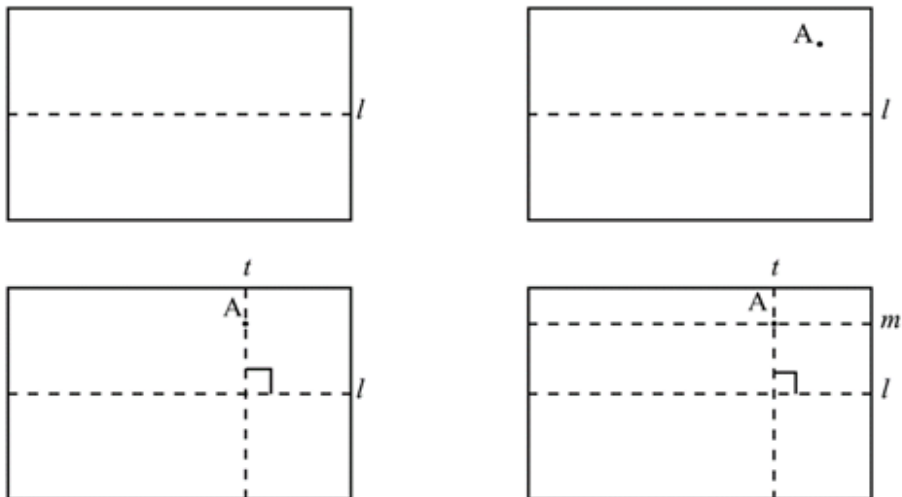

Ans:

When we fold the paper, first we make line t perpendicular to l passing through A. Then we make another line m perpendicular to t through point A. Since lines l and m are perpendicular to t , so pair of corresponding angles are equal i.e. 90° . Thus, l and m are parallel.

🔍 Figure it Out

1. Find the angles marked below.

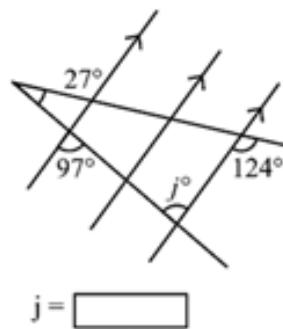
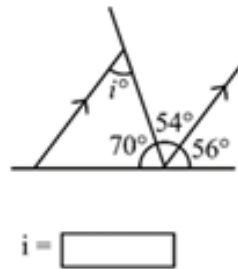
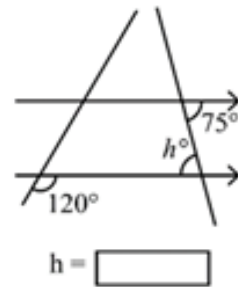
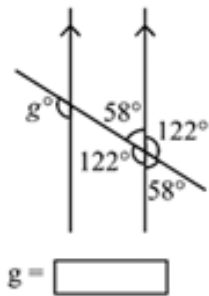
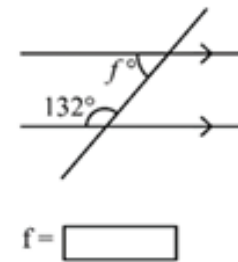
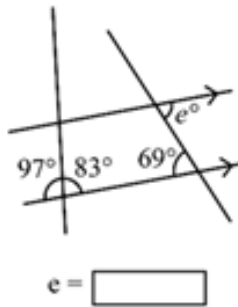
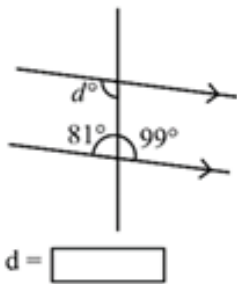
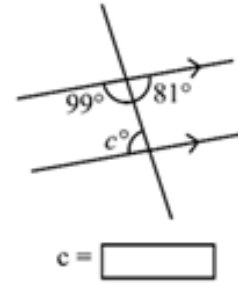
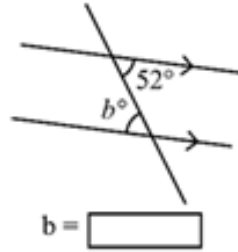
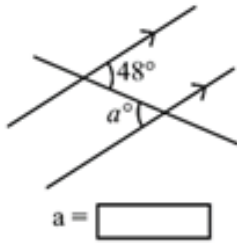

Ans:

$\angle a = 48^\circ$

$\angle b = 52^\circ$

$\angle c = 81^\circ$

$\angle d = 99^\circ$

$\angle e = 69^\circ$

$\angle f = 48^\circ$

$\angle g = 122^\circ$

$\angle h = 75^\circ$

$\angle i = 54^\circ$

$\angle j = 97^\circ$

2. Find the angle represented by a .

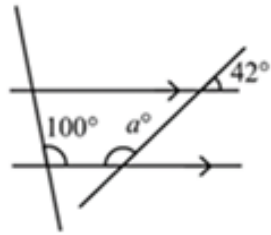

(i)

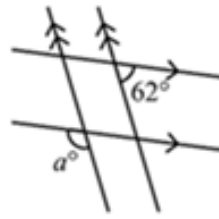

(ii)

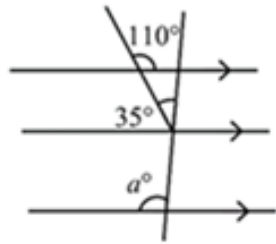

(iii)

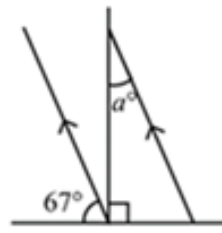

(iv)

Ans: (i) 138°

(ii) 118°

(iii) 105°

(iv) 23°

3. In the figures below, what angles do x and y stand for?

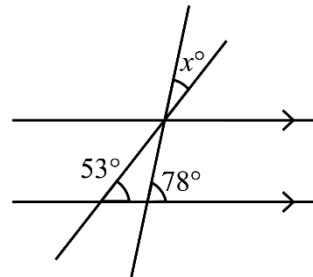
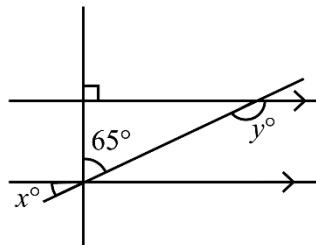

Ans:

(i) $\angle x = 25^\circ$, $\angle y = 155^\circ$ (ii) $\angle x = 25^\circ$

4. In Figure, $\angle ABC = 45^\circ$ and $\angle IKJ = 78^\circ$. Find angles $\angle GEH$, $\angle HEF$, $\angle FED$.

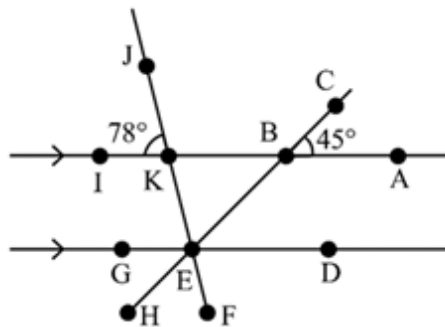

Ans: $\angle GEH = 45^\circ$;

$\angle HEF = 57^\circ$;

$\angle FED = 78^\circ$

5. In the Figure, AB is parallel to CD, and CD is parallel to EF. Also, EA is perpendicular to AB. If $\angle BEF = 55^\circ$, find the values of x and y .

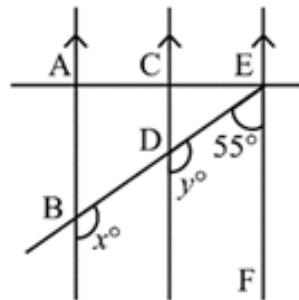

Ans: $\angle x = \angle y = 125^\circ$ [Corresponding Angles]

6. What is the measure of angle $\angle NOP$ in the given figure?

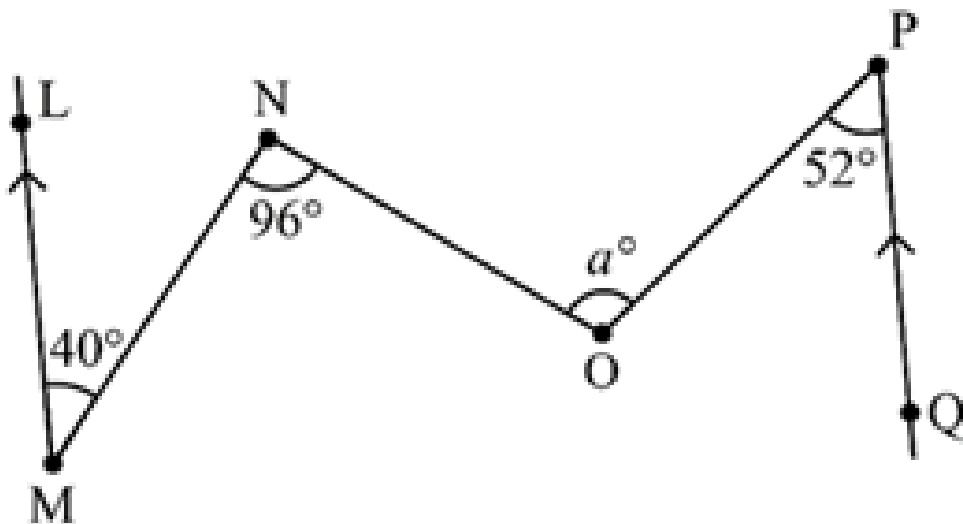

[Hint: Draw lines parallel to LM and PQ through points N and O]

Ans: $\angle NOP = 108^\circ$